

PERI UP Flex

Stair 75

Instructions for Assembly and Use – Standard Configuration – Version 2.0

UK Edition 07|2022

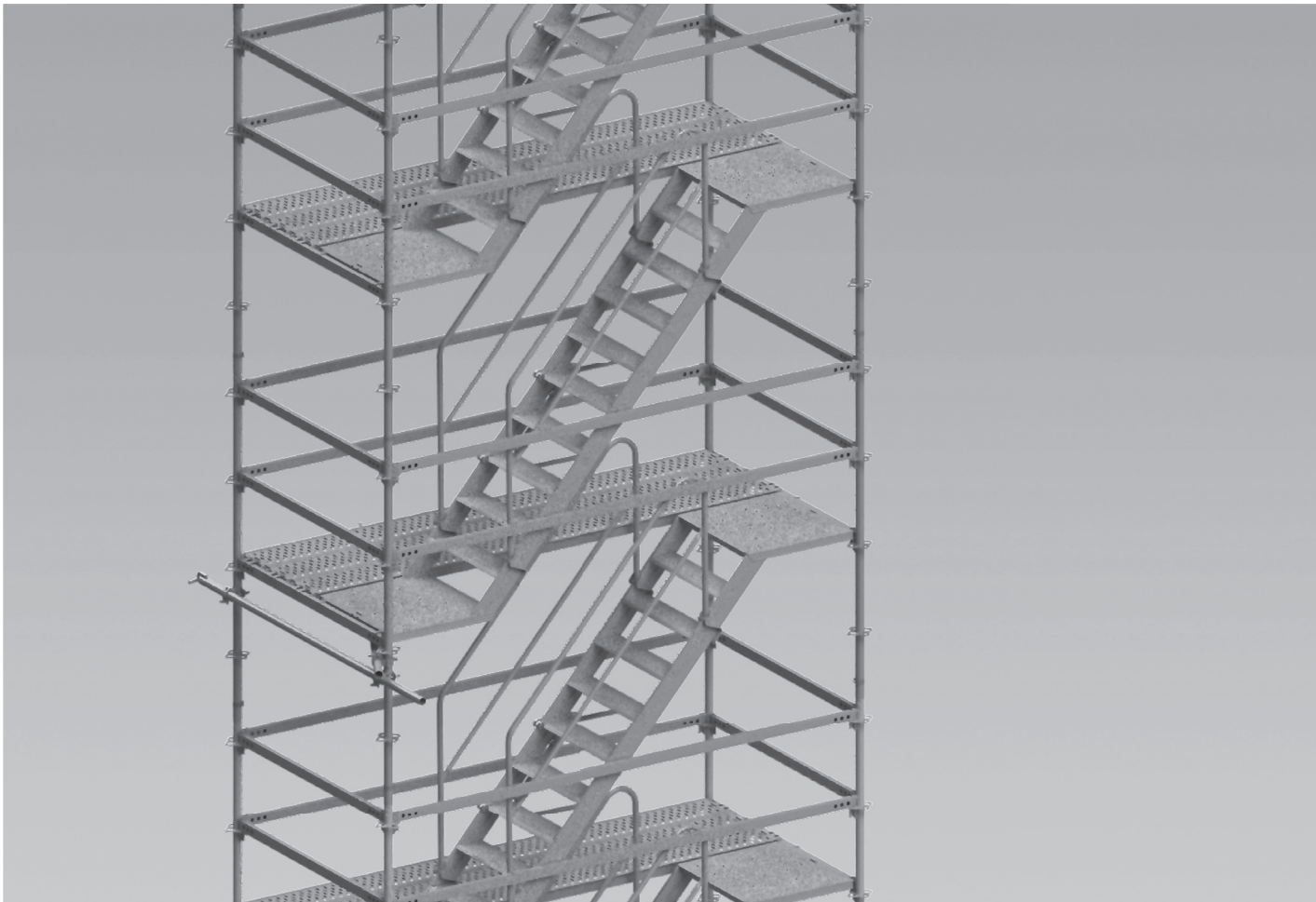

Overview

Main components	4
Key	5

Introduction

Target groups	6
Product description	7
Cleaning and maintenance instructions	8
Disposal	8
Additional technical documentation	9
Instructions for Use	9

Safety instructions

Cross-system	10
System-specific	12
Anchoring	12
Inspecting the anchoring	12
Identification marking	13
Laws and regulations	13
Inspection, handover and use	14

Safety during assembly

Verified attachment points	15
Attachment points in the system	16

Storage and transportation

General	17
During the relocation procedure	17

Flex Stair with staircase units in the same direction

A1 System structure	18
A2 Bay lengths	19
A3 Base level	20
A4 Other levels	24
A5 Uppermost level	30
A6 Intermediate access points	33
A7 Installation variants	34
Height adjustment	34
Extended lateral protection	38
A8 Disassembly	39
A9 Live loads	40
A10 Reaction forces	41
A11 Ties, tie forces	42

Flex Stair with alternating staircase units

B1 System structure	44
B2 Bay lengths	45
B3 Base level	46
B4 Other levels	50
B5 Uppermost level	56
B6 Installation variants	59
Height adjustment	59
Shaft staircase	65
Uneven heights	67
Extended lateral protection	68
B7 Intermediate access points	70
B8 Disassembly	71
B9 Live loads	72
B10 Reaction forces	73
B11 Ties, tie forces	74

Moving by crane

C1 Movement by crane	76
----------------------	----

Program overview

PERI UP Flex Stair 75	78
-----------------------	----

Appendices

PERI UP Flex Staircase 75 Assembly & Dismantling Instructions to SG4	A
--	---

Main components

Section A – Flex Stair with staircase units in the same direction

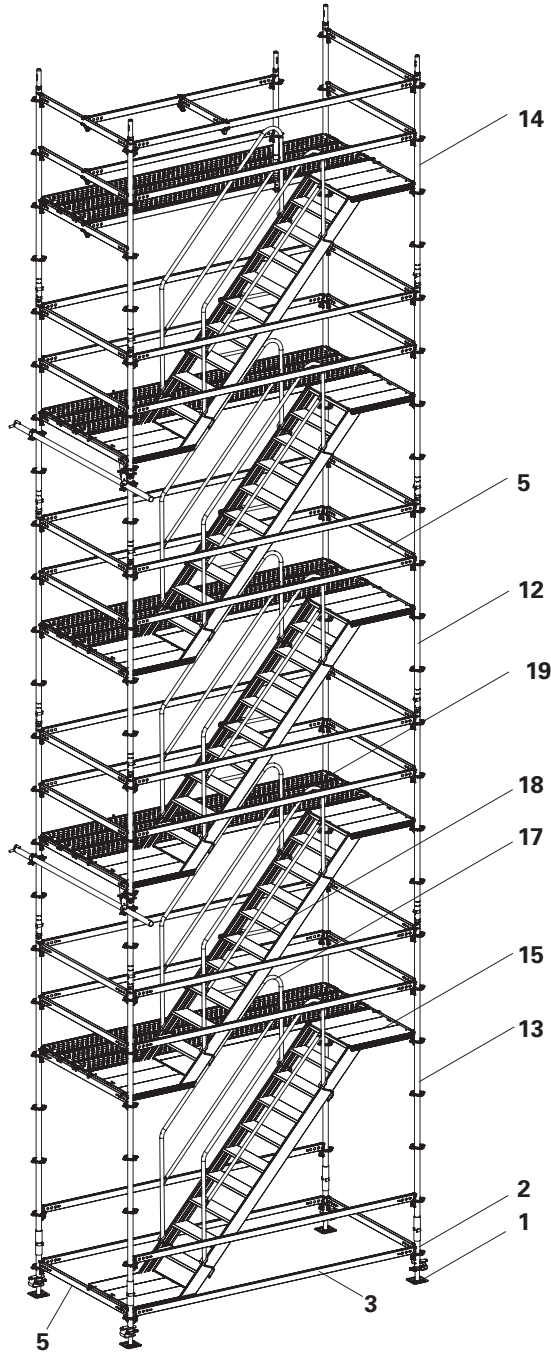



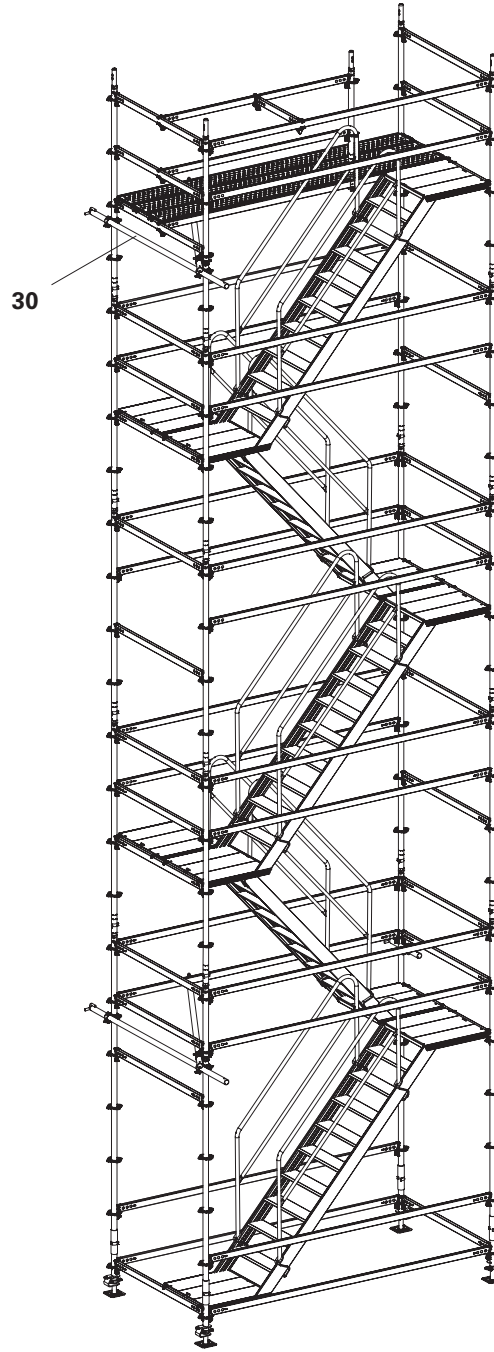









Section B – Flex Stair with alternating staircase units





- | | | | |
|----|----------------------------|----|-------------------------------|
| 1 | Base Spindle UJB | 15 | Flex Stair UAS-2 75 x 300/200 |
| 2 | Base Standard UVB 25 | 17 | Stair Guardrail UAG |
| 3 | Horizontal Ledger UH-2 300 | 18 | Stair Guardrail UAH-2 |
| 5 | Horizontal Ledger UH-2 150 | 19 | Steel Deck UDG-2 25 x 300 |
| 12 | Standard UVR-2 200 | 30 | Wall Tie UWT 220 |
| 13 | Standard UVR-2 300 | | |
| 14 | Top Standard UVH-2 | | |

Key

Pictogram | Definition

-  Danger/Warning/Caution
-  Note
-  To be complied with
-  Load-bearing point
-  Visual inspection
-  Tip
-  Incorrect use
-  Safety helmet
-  Safety shoes
-  Safety gloves
-  Safety goggles
-  Personal protective equipment to prevent falling from a height (PPE)

Arrows

-  Arrow representing an action
-  Arrow representing a reaction of an action*
-  Arrow representing forces

* If not identical to the action arrow.

Safety instruction categories

The safety instructions alert site personnel to the risks involved and provide information on how to avoid these risks. Safety instructions can be found at the beginning of the section or before instructions for action and are highlighted as follows:

Danger

This sign indicates an extremely hazardous situation which could result in death or serious, irreversible injury if the safety instructions are not followed.

Warning

This sign indicates a hazardous situation which could result in death or serious, irreversible injury if the safety instructions are not followed.

Caution

This sign indicates a hazardous situation which could result in minor or moderate injury if the safety instructions are not followed.

Note

This sign indicates situations in which failure to observe the information can result in material damage.

Format of the safety instructions

Signal word

Type and source of hazard!
Consequences of non-compliance.
⇒ Preventative measures.

Dimensions

Dimensions are usually given in cm. Other measurement units, e.g. m, are shown in the illustrations.

Conventions

- Instructions are numbered with: 1., 2., 3.
- The result of an instruction is shown by: →
- Position numbers are clearly provided for the individual components and are given in the drawing, e.g. **1**, in the text in brackets, for example **(1)**.
- Multiple position numbers, i.e. alternative components, are represented with a slash: e.g. **1/2**.

Notes on illustrations

The illustration on the front cover of these instructions is understood to be a system representation only. The assembly steps presented in these Instructions for Assembly and Use are shown in the form of examples with only one component size. They are valid for all component sizes contained in the standard configuration.

To facilitate understanding, illustrations are sometimes incomplete. Any safety equipments that are not shown in these illustrations must be incorporated nonetheless.

Terminology

Components are not always named in full so that they are easier to read. All components deemed valid according to the program overview may be used. Exceptions are specified.

Example:

- Horizontal ledger
- corresponds to:
- Horizontal Ledger UH Plus
- Horizontal Ledger UH-2.

Target groups

Scaffolding contractors/contractors

These assembly instructions are intended for contractors who either

- assemble, modify and dismantle the scaffolds, or
- use them, e.g. for pouring concrete, or
- allow them to be used for other operations, e.g. carpentry or electrical work.

Safety and Health Protection Coordinator*

- is appointed by the client,
- must identify potential hazards during the planning phase,
- determines measures that provide protection against risks,
- creates a safety and health protection plan,
- coordinates the protective measures for the contractor and site personnel so that they do not endanger each other,
- monitors compliance with the protective measures.

Competent person

- is appointed by the scaffolding contractor,
- must be on site for all scaffolding work,
- prepares and updates the plan for assembly, modification and dismantling,
- prepares and updates the plan for use of the scaffold by the scaffold user,
- supervises the assembly, modification and dismantling work (supervisor).

Competent persons qualified to carry out inspections

Due to the specialist knowledge gained from professional training, work experience and recent professional activity, the competent person qualified to carry out inspections has a reliable understanding of safety-related issues and can carry out inspections correctly. Depending on the complexity of the inspection to be undertaken, e.g. scope of testing, type of testing or the use of certain measuring devices, a range of specialist knowledge is necessary.

Qualified personnel

Scaffolds may only be assembled, modified or dismantled by personnel who are suitably qualified to do so. Qualified personnel must have completed a course of training** in the work to be performed, covering the following points at least:

- Explanation of the plan for the assembly, modification or dismantling of the scaffold in an understandable form and language.
- Description of the measures for safely assembling, modifying or dismantling the scaffold.
- Naming of the preventive measures to be taken to avoid the risk of persons and objects falling.

- Designation of the safety precautions in the event of changing weather conditions that could adversely affect the safety of the scaffold, as well as the personnel concerned.
- Details regarding permissible loads.
- Description of all other risks and dangers associated with assembly, modification or dismantling operations.



- **In other countries, ensure that the relevant national guidelines and regulations in the respective current version are complied with!**
- **If no country-specific regulations are available, it is recommended to proceed according to German guidelines and regulations**

* Valid in Germany: Regulations for Occupational Health and Safety on Construction Sites 30 (RAB 30).

** Instructions are given by the contractor themselves or a competent person selected by them.

Product description

Purpose of these assembly instructions

These Instructions for Assembly and Use describe the processes of assembling and disassembling the standard configuration and are based on the approval for the PERI UP Flex Scaffolding System Z-8.1-863.

Intended use

Use as Flex Stairs with staircase units in the same direction and Flex Stairs with alternating staircase units as a means of access for temporary work to be carried out on working areas situated above ground level.

PERI products have been designed for exclusive use in the industrial and commercial sectors only by suitably trained personnel.

Features

The stair is based on PERI UP Flex Modular Scaffolding with supplementary components.

For use as a Flex Stair with alternating staircase units or with staircase units in the same direction from 2.0 m up to a maximum of 66.0 m assembly height together with associated anchoring.

Permissible loads: for flights of stairs and decks

2.0 kN/m²

for the complete construction

2.0 kN/m²

per 20 m linear metres

- Flight of stairs corresponds to class B in accordance with EN 12811, Part 1.

Technical data

Version 1: 150 x 250 cm

Version 2: 150 x 300 cm

Storey height 200 cm

Clear tread width 67 cm, deck width 71 cm.

Cleaning and maintenance instructions

Clean the scaffolding components after each use to maintain the value and operational readiness of the PERI products over the long term.

Some repair work may also be inevitable due to the tough working conditions.



The contractor must ensure that the personal protective equipment required for cleaning, maintenance and repair work such as

- safety helmet,
- safety shoes,
- safety gloves,
- safety goggles,

is available and used as intended.

The following instructions should help to keep cleaning and maintenance costs as low as possible.

Cleaning tools must be adapted to the respective surfaces of the components so that they are not damaged.

Mechanical components, e.g. spindles, must be cleaned of dirt or concrete residue before and after use, and then greased with a suitable lubricant.

Do not use plastic components if fibre reinforcements are exposed.

Provide suitable support for the components during cleaning so that no unintentional change in their position is possible.

Do not clean components suspended on crane lifting gear.

Components with wood parts are to be stored in well-ventilated and dry conditions.

Any repairs to PERI products are to be carried out by PERI qualified personnel only.

Disposal

Dispose of in accordance with the relevant national regulations.

Additional technical documentation

- Approvals:
 - Approval Z-8.22-863 PERI UP Flex module system
- Instructions for Assembly and Use:
 - PERI UP Scaffolding Kit core components
- User information:
 - Pallets and stacking devices
- Brochure
 - PERI UP Access Technology

Instructions for Use

Use in a way not intended, deviating from the standard configuration or the intended use according to the Instructions for Assembly and Use, represents an application with a potential safety risk, e.g. risk of falling.

Deviations from the standard configuration must be verified for the application by means of separate strength and stability calculations (Industrial Safety Regulation Appendix 1, No. 3.2.1) and explicitly reflected in the assembly instructions.

All components listed in the program overview may be used for assembly. Other components are not permitted. Exceptions are named or must be planned and verified on a project-specific basis.

The use of other products and spare parts is not allowed. Changes to PERI components are not permitted.

The system described in these Instructions for Assembly and Use may contain patent-protected components.

Cross-system



Safety instructions apply to all service life phases of the system.

General

The contractor must guarantee that the Instructions for Assembly and Use supplied by PERI are available at all times and understood by the site personnel.

These Instructions for Assembly and Use can be used as the basis for creating a risk assessment. The risk assessment is compiled by the contractor. However, the Instructions for Assembly and Use are not a substitute for a risk assessment!

Observe and comply with the safety instructions and permissible loads.

For the application and inspection of PERI products, the current safety regulations and guidelines valid in the respective countries must be observed.

Materials and working areas are to be inspected before each use and assembly for:

- damage,
- stability and
- functional correctness.

Damaged components must be exchanged immediately on site and may no longer be used.

Safety components are to be removed only when they are no longer required.

When on slab formwork, scaffolds, staircase landings and working platforms:

- do not jump,
- do not run,
- do not drop anything from or onto it.

Components provided by the contractor must comply with the characteristics stipulated in these Instructions for Assembly and Use and all applicable laws and standards. Unless otherwise indicated, the following applies in particular:

- Timber components: strength class C24 for solid wood according to EN 338.
- Scaffolding tubes: galvanised steel tubing with minimum dimensions of $\varnothing 48.3 \times 3.2$ mm according to EN 12811-1:2003 4.2.1.2.
- Scaffolding tube couplings according to EN 74-1 and EN 74-2.

Deviations from the standard configuration are only permitted after a further risk assessment has been carried out by the contractor.

Appropriate measures for working and operational safety, as well as stability, are defined on the basis of this risk assessment.

Corresponding proof of stability can be provided by PERI on request, if the risk assessment and resulting measures to be implemented are made available.

Before and after exceptional occurrences that may have an adverse effect on the safety of the scaffolding system, the contractor must immediately

- produce another risk assessment and make use of its results to take suitable steps to guarantee the stability of the scaffolding system,
- arrange for an extraordinary inspection to be carried out by a competent person qualified to do so. The aim of this inspection is to identify and rectify any damage in good time in order to guarantee safe use of the scaffolding system.

Exceptional events could be:

- accidents,
- long periods of non-use,
- natural events, e.g. heavy rainfall, icing, heavy snowfall, storms or earthquakes.

Assembly, modification and dismantling work

Assembly, modification or dismantling of scaffolding systems may only be carried out by qualified persons under the supervision of a competent person. The qualified personnel must have received appropriate training for the work to be carried out with regard to specific risks and dangers.

On the basis of the risk assessment and the Instructions for Assembly and Use, the contractor must create installation instructions to guarantee safe assembly, modification and dismantling of the scaffolding system.

Before initial use, the safe functioning of the scaffold must be checked by a person qualified to carry out the inspection. The results of the inspection must be documented in an inspection log.



The contractor must ensure that the personal protective equipment required for the assembly, modification or dismantling of the scaffolding system, e.g.

- safety helmet,
- safety shoes,
- safety gloves,
- safety goggles,

is available and used as intended.

The scaffolding is disassembled by reversing the assembly sequence as described in these Instructions for Assembly and Use.

Comply with the respective assembly descriptions and safety instructions when making modifications or additions to the scaffold.



If personal protective equipment against falling from a height (PPE) is required or specified in local regulations, the contractor must determine appropriate attachment points on the basis of the risk assessment.

The PPE to be used to prevent falling is determined by the contractor.

The contractor must

- provide safe working areas for site personnel, which are to be reached through the provision of safe access ways. cordon off and clearly mark danger zones.
- guarantee stability during all stages of construction, in particular during assembly, modification and dismantling operations.
- ensure and demonstrate that all loads that occur are safely transferred.

Use

Every contractor who uses or allows the scaffolding systems to be used, is responsible for ensuring that the equipment is in good condition.

If the scaffolding system is used successively or at the same time by several contractors, the health and safety coordinator must point out any possible mutual hazards and all work must then be coordinated.

When scaffolds are used in publicly accessible areas,

- measures to prevent unauthorised use, e.g. enclosure of access areas, must be taken.
- Measures are taken against injuries caused by bumping against protruding components, e.g. assembly of protective components.

Always keep the contact surfaces of the scaffold free of dirt, objects, snow and ice.

Close off the scaffold in extreme weather conditions.

System-specific

If necessary, use load-distributing supports, e.g. planks, to match the substrate. If multiple layers are required, planks are to be arranged crosswise. It must be ensured that the scaffolding cannot shift in a horizontal direction, irrespective of what substrate is being used.

Couplings with screw closures must be tightened with 50 Nm. This corresponds to a force of 20 kg using a lever arm length of 25 cm.

Secure the wedges with a jarring blow using a 500 g hammer.

Only use approved lifting gear.

Anchoring

The load-bearing capacity of the fastening means between the wall ties and the anchoring base must be verified for the specified tie loads on the construction site. The anchoring forces and the position of the anchoring are described in the section on reaction forces.

The enclosure of the scaffolding or mounting of additional surfaces exposed to the wind changes the stability and must be rechecked. If necessary, additional measures must be implemented.

Anchoring must be installed progressively with the erection of the scaffold assembly.

The anchoring forces must be transferred into sufficiently load-bearing anchorage via wall ties and fixing materials e.g. the building.

Inspecting the anchoring

The anchoring and its components must be inspected by a qualified person nominated by the scaffolding contractor.

Load tests must be carried out at the place of use.

Load tests are to be carried out using suitable test equipment.

The test load must be 1.2 times higher than the required anchoring force F_{\perp} .

The scope of testing must, however, include a minimum of 5 load tests for all dowels used for concrete anchoring bases (at least 10%) and for other building materials (at least 30%).



Ensure that the relevant national guidelines and regulations are complied with!

Identification marking

When carrying out the work the following signs must be observed:

If certain parts of the scaffold are not ready for use – especially during assembly, modification and dismantling – a “No Entry” warning sign restricting access must be clearly displayed (Fig. S.01).

In addition, the area must be adequately closed off in order to prevent access.



Fig. S.01

After assembly has been completed, all scaffold entry points must clearly display the designated sign. (Fig. S.02)

The identification marking do not replace the inspection log! (Fig. S.03, rear side)

Montageprotokoll

auszufüllen vom Aufsichtführenden

Aufstellort _____
 Position _____
 Auftraggeber _____
 Gerüstersteller _____
 Datum _____
 Unterschrift _____

Arbeitsgerüst nach EN 12811, für Lastklasse

<input type="checkbox"/>	kN/m ²	1-2: Wertungsarb. 1,50 kN/m ² 3: Malerei, Putzarb. 2,00 kN/m ² 4-6: Maurerarb. ≥ 2,00 kN/m ²
--------------------------	-------------------	---

Breitenklasse W

<input type="checkbox"/>	W06 0,6 ≤ w ≤ 0,9 m	
<input type="checkbox"/>	W09 0,9 ≤ w ≤ 1,2 m	
<input type="checkbox"/>	W12-W24 w ≥ 1,2 m	

Abnahmeprotokoll

auszufüllen vom Prüfer

Name _____
 Unterschrift _____
 Datum, Uhrzeit _____
 Besonderheiten _____

© 2007 PERI GmbH All Rights Reserved 113833

Fig. S.02

Prüfprotokoll

Prüfung durch befähigte Person

⚠ Achtung

Veränderungen am Gerüst, z.B. Entfernen der Verankerungen, dürfen nur vom Gerüstersteller durchgeführt werden.

Datum	Uhrzeit	Unterschrift

Gerüst stillgelegt:
Datum: _____

Fig. S.03, rear side

Laws and regulations

When assembling, modifying, dismantling and using the scaffolds in Germany, accident prevention regulations and guidelines of the employer's liability insurance associations, as well as national health and safety regulations, must be followed, especially:

- German Product Safety Act (ProdSG)
- Directive 2009/104/EC
- Operating Safety Regulation (BetrSichV)
- Statutory Accident Insurance (DGUV) Information 201-011
- BGV A1 (Trade Association Regulations)
- TRBS 2121 (Technical Regulations for Operational Safety)
- TRBS 1203 (Technical Regulations for Operational Safety)
- Regulations for Occupational Health and Safety on Construction Sites 30 (RAB 30)

The latest version in each case is applicable.



- **Ensure that the relevant national guidelines and regulations in the respective current version are complied with!**

Inspection, handover and use

The erected scaffold must be inspected by the scaffolding contractor in order to determine that assembly has been carried out correctly. If the contractor is convinced that the scaffold has been correctly erected, it can then be handed over to the user.

It is advisable to carry out the handover with the user and, for example, to document this in a written report.



During the handover, the scaffolding contractor must advise the user of any possible risks involved with non-intended use and his obligation to provide adequate prevention against risk and danger!

- Put up safety and warning signs at the scaffold access point.
- Handover of a usage plan.



The contractor who uses scaffolding, must ensure that the scaffolding is in good condition and not arbitrarily altered in any way. In this respect, the qualified specialists must be instructed that if changes have obviously been made during use, these must be reported to the respective qualified and competent person.

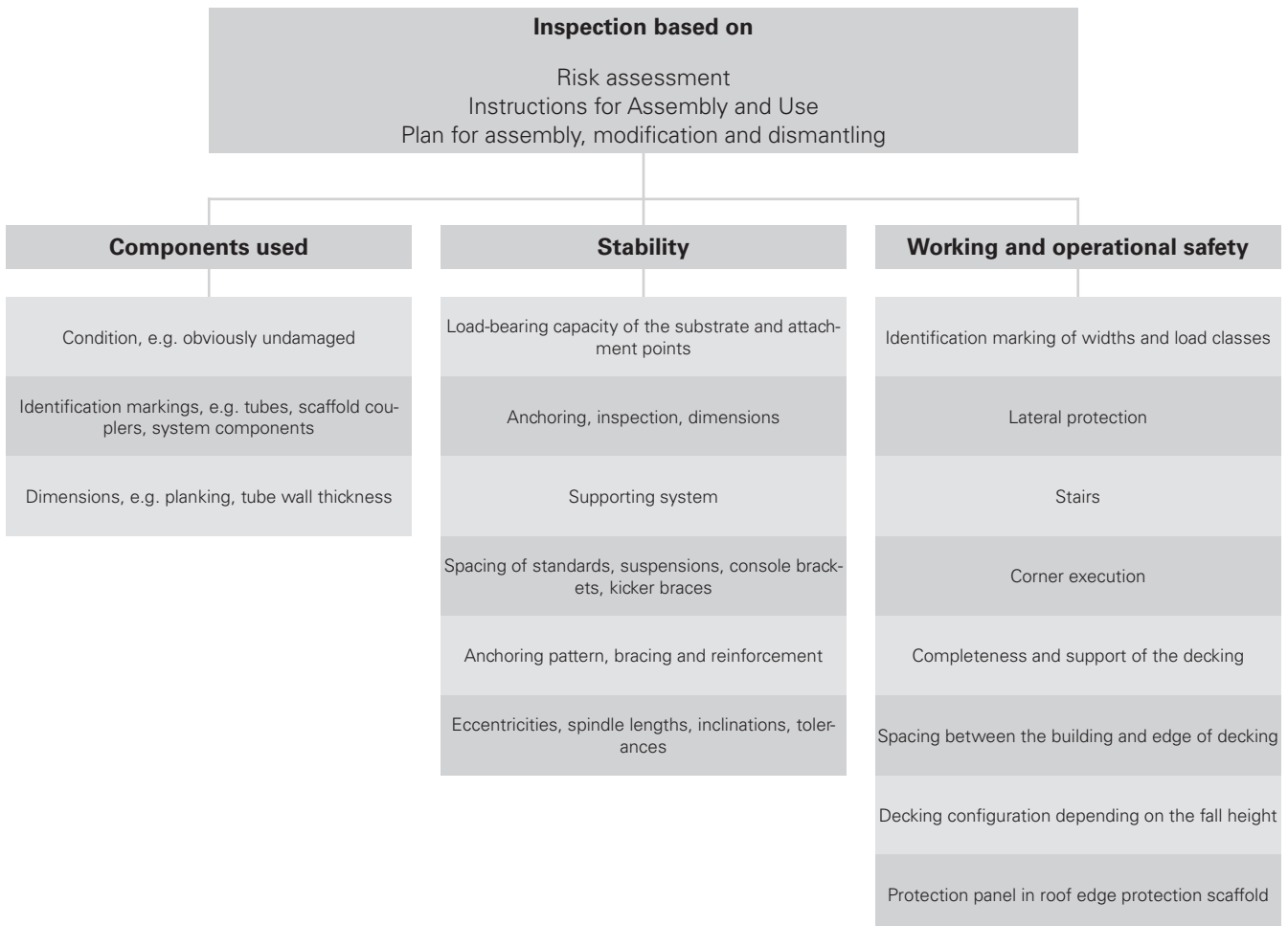

Source: based on TRBS 2121 Part 1

Verified attachment points

Certain assembly situations could occur that require the use of personal protective equipment (PPE) to prevent falling from a height. For this, the following verified attachment points must be used:

All attachment points require the following:

- The standing height can be a maximum of one level above the last anchoring position.
- At least one anchoring layer must always be present, or the scaffold is verified to be free-standing and the tilt resistance is guaranteed.

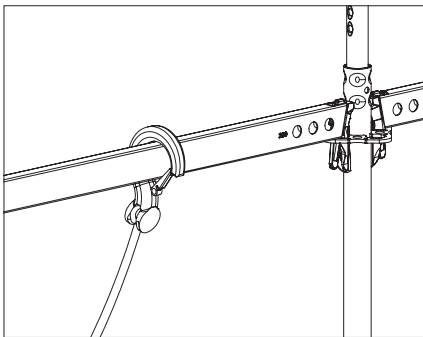

Fig. M.01

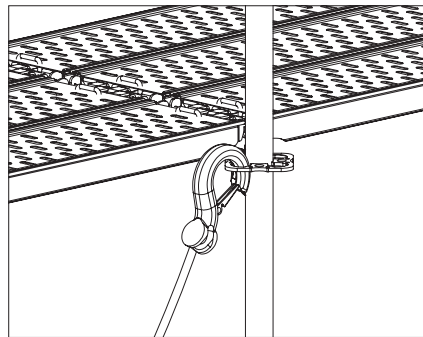

Fig. M.02

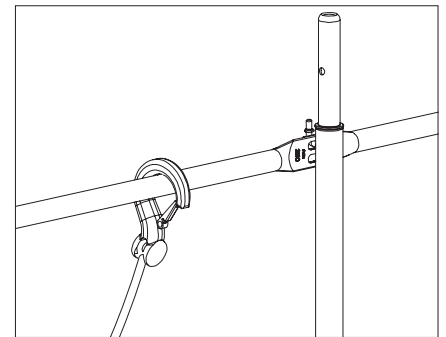

Fig. M.03

Horizontal ledger

Attachment point:

Each Horizontal Ledger UH Plus or UH-2,

- which is freely accessible for the lifting gear
- and is installed at a maximum height of 1.0 m above the deck level
- and which is wedged on two rosettes of 2 standards.

The standards must be butt-jointed at least 0.5 m below the deck level.

Rosette

Attachment point:

Each rosette that is integrated into the base scaffold. See rules and regulations on the right.

Guardrail post

Attachment point:

Each Guardrail Post EPG,

- which is connected to two Standards UVR, UVR-2 or UVH
- and both the guardrail post and the intermediate guardrail (UH-Plus or UH-2) are installed
- and is mounted a maximum 1.0 m above the deck level.

The standards must be butt-jointed at least 0.5 m below the deck level.

Attachment points in the system



Each specified attachment point is intended for securing only one person!

General information

- The use of personal protective equipment to prevent falling from a height is regulated in the project-related risk assessment that has been prepared by the contractor (user).
- When using personal protective equipment to prevent falling from a height, all valid standards and safety regulations are to be taken into consideration by the contractor.
- Each scaffold assembly is to be secured against tipping by the user.
- The application concerns assembly, reconstruction and dismantling.
- The specified heights for permissible attachment points apply only in relation to the component. The respective employer risk assessment regulates the attachment points to be used for the person

Requirements

- The scaffold assembly underneath the final assembly level is complete. This means, all ledgers and diagonal bracing have been installed and the decking is in place as the topmost assembly level.
- The joints of the topmost standards must lie underneath the last assembly level.

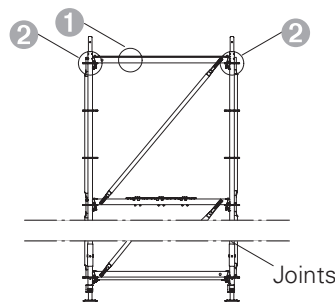

Fig. M.04

Attachment points

Standard ends approx. 2 m below the assembly level:

- each horizontal ledger in the assembly level ①,
- each rosette in the assembly level ②

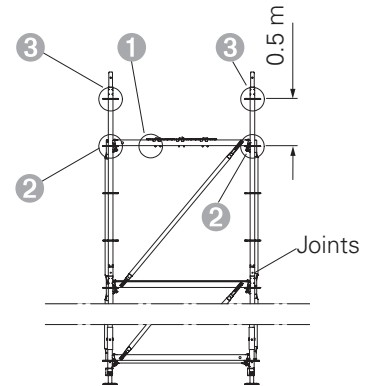

Fig. M.05

Attachment points

Standard ends approx. 1.5 m below the assembly level:

- each horizontal ledger in the assembly level ①,
- each rosette up to max. 0.5 m above the last assembly level ②, ③.

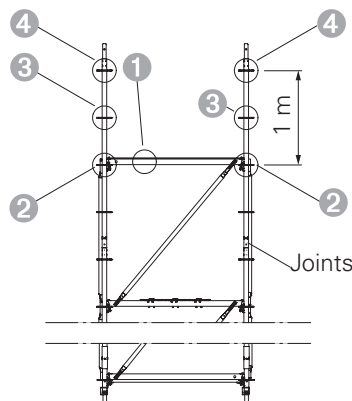

Fig. M.06

Attachment points

Standard ends approx. 1 m below the assembly level:

- each horizontal ledger in the assembly level ①,
- each rosette up to max. 1.0 m above the last assembly level ② ③ ④.

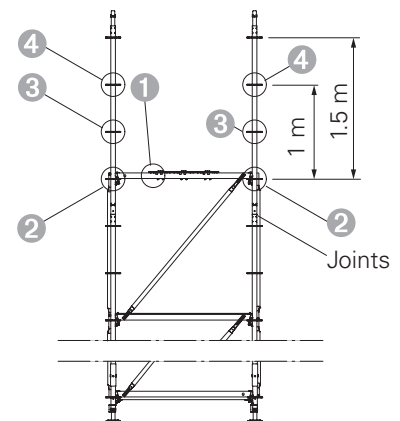

Fig. M.07

Attachment points

Standard ends approx. 0.5 m below the assembly level:

- each horizontal ledger in the assembly level ①,
- each rosette up to max. 1.0 m above the last assembly level ② ③ ④.

General

- Store and transport components in such a way that no unintentional change in their position is possible. Detach lifting accessories and lifting gear from the lowered components only if they are in a stable position and no unintentional change is possible.
- Do not drop the components.
- Only ever use approved and inspected means of transportation from PERI incl. lashing, lifting gear and slings.
- Only attach the means of transport to the intended attachment points using suitable lifting gear and slings.

During the relocation procedure

- ensure that components are picked up and set down in such a way that unintentional falling over, falling apart, sliding, falling down or rolling is avoided.
- no one is allowed to remain under the suspended load.
- always guide pre-assembled scaffolding bays, scaffolding units or scaffolding sections with ropes when moving them by crane.
- The access areas on the construction site must be free of obstacles and tripping hazards and must also be slip-resistant.
- For transportation, the substrate must have sufficient load-bearing capacity.
- Use original PERI storage and transport systems, e.g. crate pallets, pallets or stacking devices.

General



- For basic information on the assembly of PERI UP, see the assembly instructions for PERI UP Scaffolding Kit core components
- 2 people are required to carry out the assembly of the stair elements.

Flex Stair with staircase units in the same direction

With anchoring and access to the building.

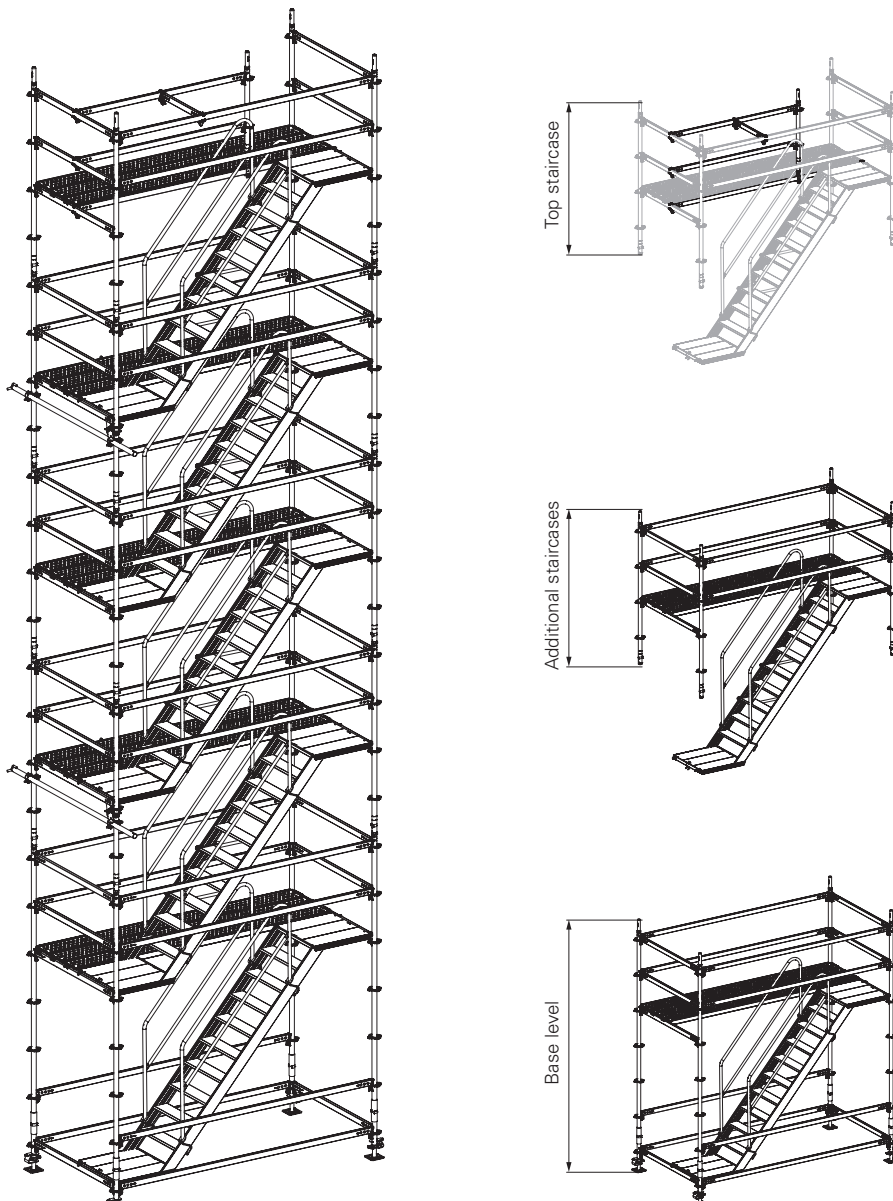

Fig. A1.01

General

The PERI UP Flex Stair 75 system can be assembled in bay lengths of 250 cm or 300 cm

The following sections show the assembly process for a bay length of 300 cm.

The figures apply accordingly to the bay length of 250 cm.

Modifications for bay length 250 cm

Replace or reduce the following components:

Horizontal Ledger UH-2 300 **(3)**
→ Horizontal Ledger UH-2 250

Horizontal Ledger UH-2 200 **(4)**
→ Horizontal Ledger UH-2 150

Flex Stair UAS-2 75 x 300/200 **(15)**
→ Flex Stair UAS-2 75 x 250/200

Steel Deck UDG-2 25 x 300 **(19)**
→ Steel Deck UDG-2 25 x 250

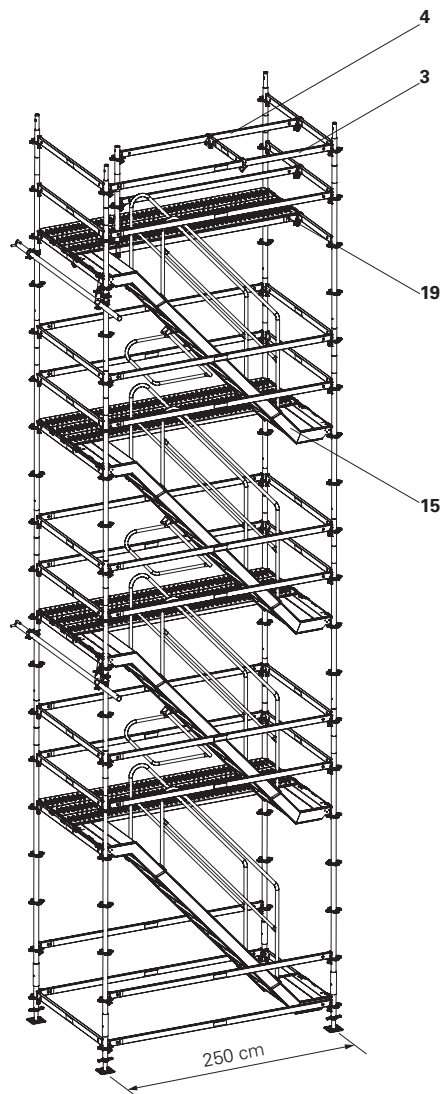

Fig. A2.01

Refer to Instructions for Short Lift systems to NASC SG4:15

Base level

Components

- 1 Base Spindle UJB
- 2 Base Standard UVB 25
- 3 Horizontal Ledger UH-2 300
- 5 Horizontal Ledger UH-2 150

Assembly

1. Assemble frame.
Distance to building ≤ 30 cm.
(Fig. A3.01)
2. Horizontally align frame by adjusting the Base Spindles UJB (1). Spindle extension:
– for assembly heights up to 36 m:
Lsp ≤ 30 cm,
– for assembly heights over 36 m:
Lsp ≤ 20 cm. (Fig. A3.02)
3. Secure wedges on all ledgers using a 500 g hammer. (Fig. A3.04 – Fig. A3.06)
4. Fit Steel Decks UDG-2 (19) in the base level as an installation aid. (Fig. A3.03 + Fig. A3.03a)



- All ledgers must be at a 90° angle to each other. (Fig. A3.02)
- For crane relocation purposes, spindle out the Base Spindle UJB by at least 17 cm. This is the only way to ensure a tension-proof connection between the Base Standard UVB and the Standard UVR-2 with locking pins



Install base standards and standards with holes lined up in the same direction. This procedure allows the tubes to be joined with locking pins for crane use at any time.

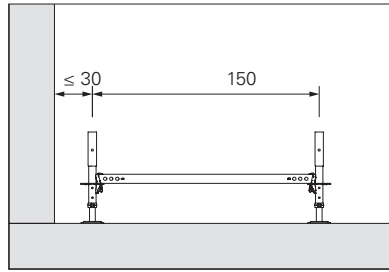

Fig. A3.01

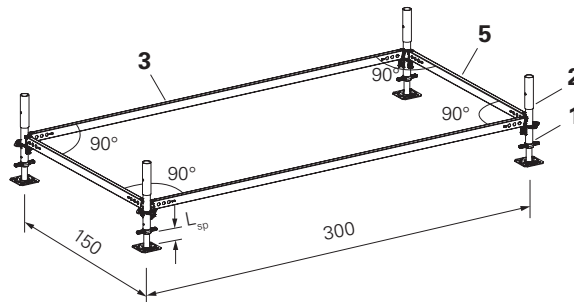

Fig. A3.02

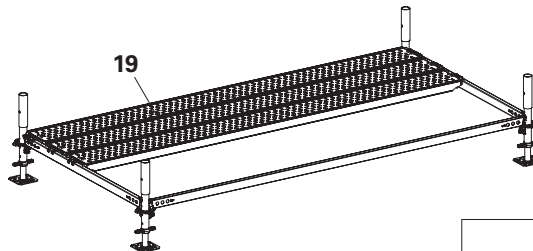

Fig. A3.03

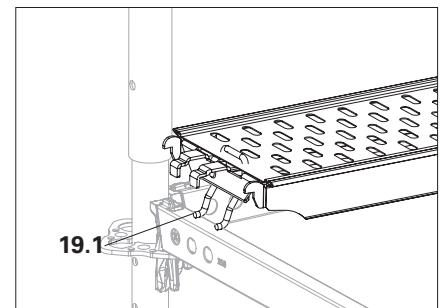

Fig. A3.03a

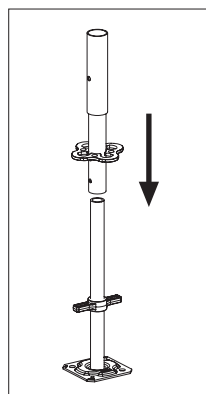

Fig. A3.04

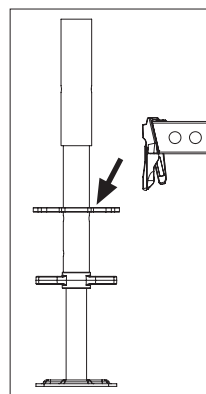

Fig. A3.05

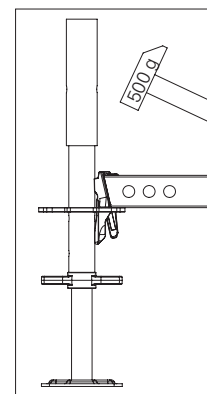

Fig. A3.06

Standards and ledgers

Components

- 3** Horizontal Ledger UH-2 300
- 5** Horizontal Ledger UH-2 150
- 13** Standard UVR-2 300
- 35** Spindle Locking UJS

Assembly

1. Insert Standards UVR-2 (**13**).
2. Fit Steel Decks UDG-2 (**19**) in the base level as an installation aid. (Fig. A3.07 + Fig. A3.07a)
3. Attach Horizontal Ledgers UH-2 150 (**5**) and secure wedges with hammer blow.
4. Attach Horizontal Ledgers UH-2 300 (**3**) and secure wedges with hammer blow. (Fig. A3.07)
5. If movement by crane is envisaged, fit Spindle Locking UJS (**35**).

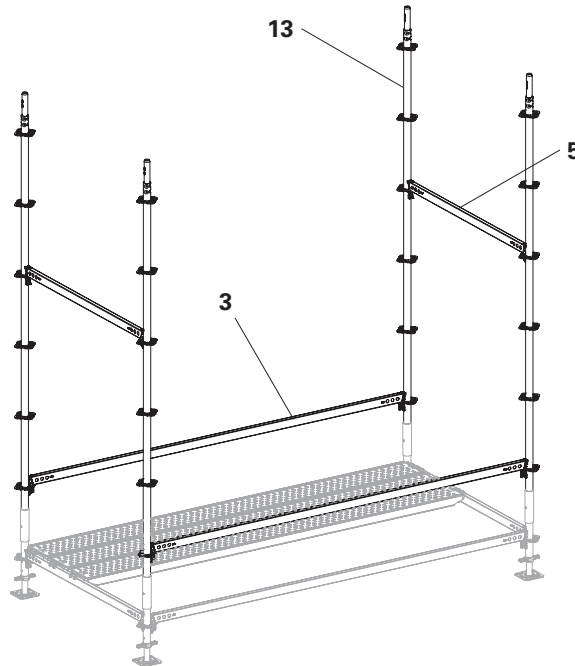

Fig. A3.07

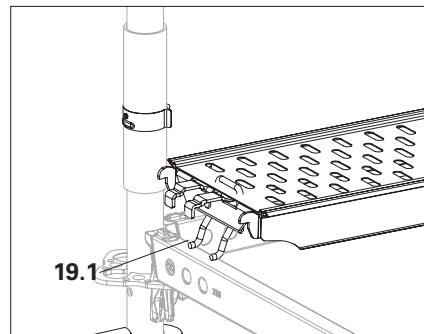

Fig. A3.07a

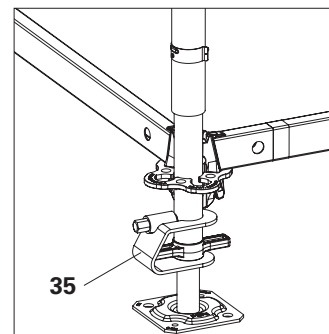

Fig. A3.07b

Flex Stair and guardrail

Components

- 3 Horizontal Ledger UH-2 300
- 5 Horizontal Ledger UH-2 150
- 15 Flex Stair UAS-2 75 x 300/200
- 17 Stair Guardrail UAG
- 19 Steel Deck UDG-2 25 x 300

Assembly

1. Attach the Flex Stair UAS-2 (15) to the upper horizontal ledger (5a) first, then to the lower horizontal ledger (5b). (Fig. A3.08 + Fig. A3.08a)
3. Fit 2 x Stair Guardrails UAG (17 + 17a). (Fig. A3.08 + Fig. A3.08b)



All lift locks (15.1+ 19.1) must drop beneath the horizontal ledgers. If they do not, lift the component slightly and let it drop into position or operate the lift lock manually.



- If the scaffolding bays are larger, then the installation width must be limited to the dimensions of the stairs in question. For the staircase units in the same direction, limit the installation width to 75 cm to prevent lateral shifting. The UH Spigot-2, for example, would be suitable for this purpose.
- Alternatively, leave steel decks in the base level as an additional standing surface.
- Internal guardrails (17a) are not always required. Observe country-specific regulations:



The inside railing can be mounted one level higher if the country-specific regulations allow for this. This means that the handrail will already be at hand height from the landing platform level when accessing from above. (Fig. A3.08c)

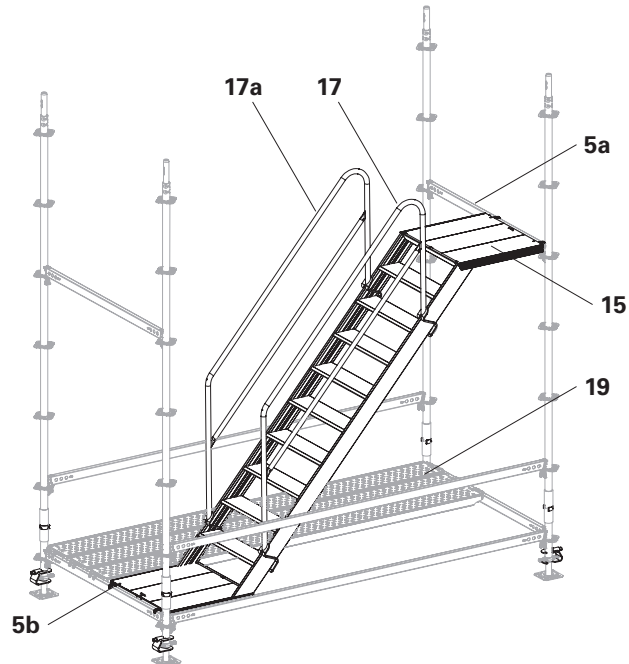

Fig. A3.08

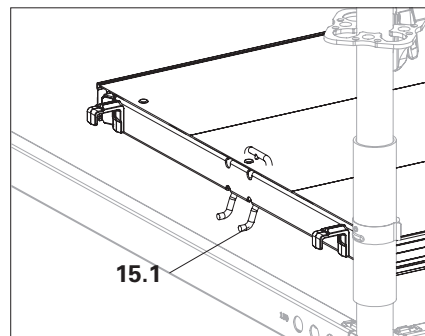

Fig. A3.08a

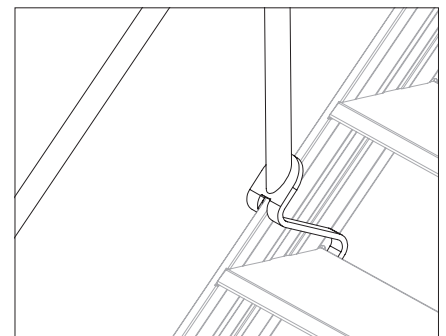

Fig. A3.08b

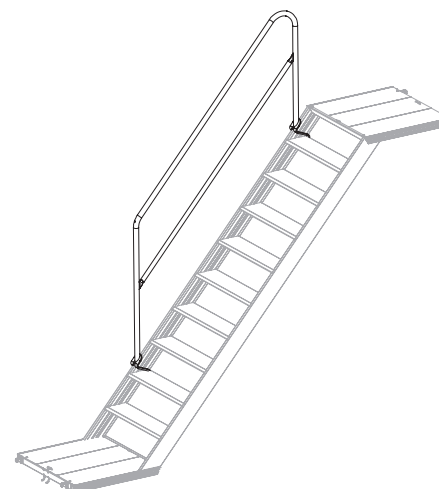

Fig. A3.08c

4. Fit 3 x Steel Decks UDG-2 (19) next to the Flex Stair. (Fig. A3.09)



All lift locks must drop beneath the horizontal ledgers. If they do not, lift the component slightly and let it drop into position or operate the lift lock manually.

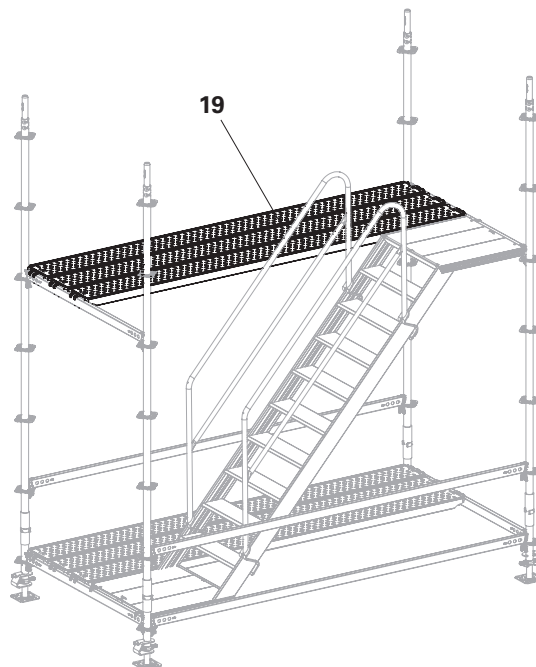

Fig. A3.09



Warning

Risk of falling due to lack of lateral protection! A fall can result in serious injuries or even death.

⇒ Do not enter the danger zone.

⇒ Use PPE.

5. Fit 2 x Horizontal Ledgers UH-2 150 (5) and 4 x Horizontal Ledgers UH-2 300 (3). Hammer all wedges into place. (Fig. A3.10)



The assembly sequence shown assumes that the stair is brought in via the open front side.

If the contractor carries out an additional risk assessment, a different assembly sequence is permissible.

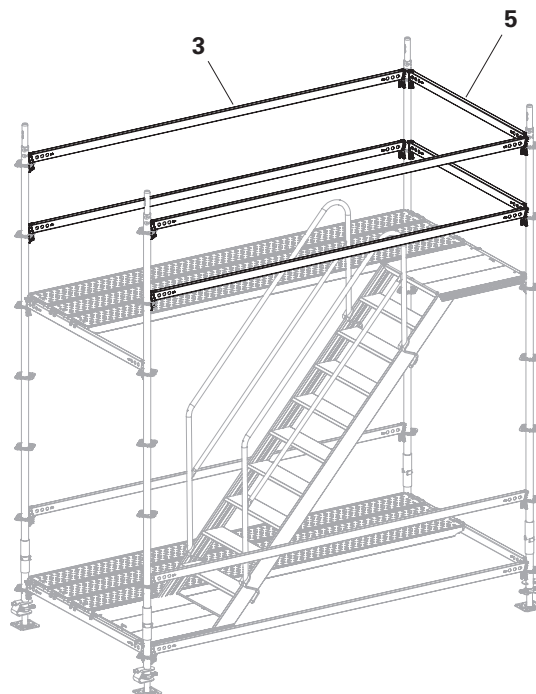

Fig. A3.10

Standards and ledgers

Components

5 Horizontal Ledger UH-2 150

12 Standard UVR-2 200

Assembly

1. Insert Standards UVR-2 (**12**).
2. Fit Horizontal Ledgers UH-2 (**5**) and secure wedges with hammer blow. (Fig. A4.01)
3. If relocation by crane is envisaged, connect all verticals with locking pins D48/D57 (**36**) so that they are tension-proof. (Fig. A4.01a)

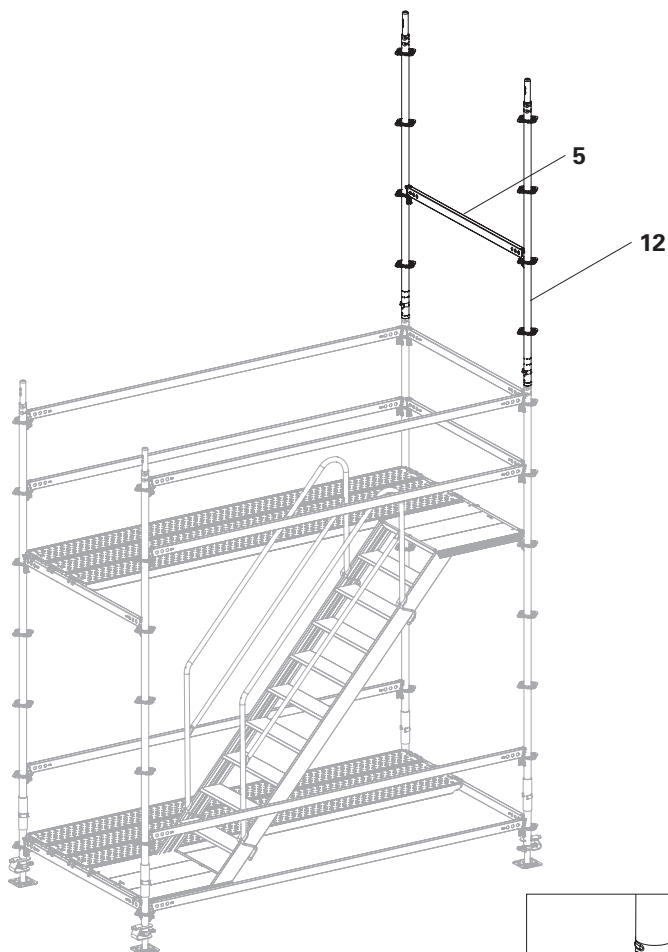

Fig. A4.01

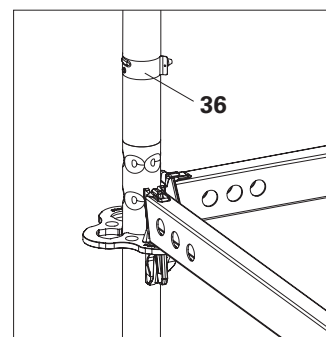

Fig. A4.01a

Flex Stair and guardrail

Components

- 5** Horizontal Ledger UH-2 150
- 12** Standard UVR-2 200
- 15** Flex Stair UAS-2 75 x 300/200
- 17** Stair Guardrail UAG
- 18** Stair Guardrail UAH-2

Assembly

1. Place Flex Stair UAS-2 (**15**) on top and bottom Horizontal Ledgers UH-2 (**5**).
2. Complete the lateral protection on the front side using 2 x Horizontal Ledgers UH-2 (**5**).
3. Fit 2 x Stair Guardrails UAG (**17** + **17a**). (Fig. A4.02)
4. From the back of the stair, fit Stair Guardrail UAH-2 (**18**) with upper suspension (**18.1**) onto the 5th step from the top. Swing out the locking pin (**18.2**) and pull it down between the stair tower and the stair guardrail. (Fig. A4.02a)
5. Fit 2 x Standards UVR-2 200 (**12**).
6. Connect standards (**12**) with Horizontal Ledgers UH-2 150 (**5a**) at a height of 2 m. Secure the wedges. (Fig. A4.02)

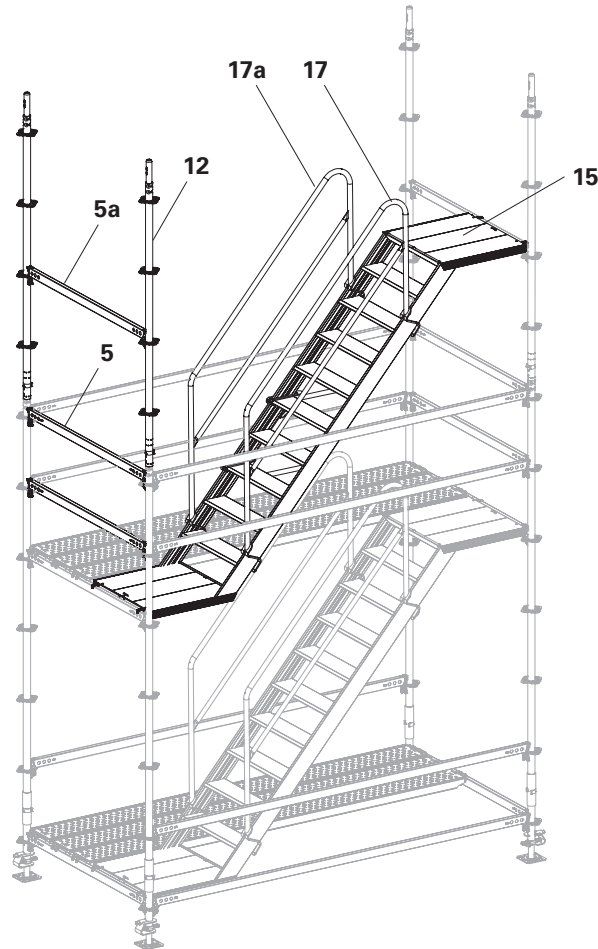

Fig. A4.02



Internal guardrails (**17a**) are not always required. Observe country-specific regulations.

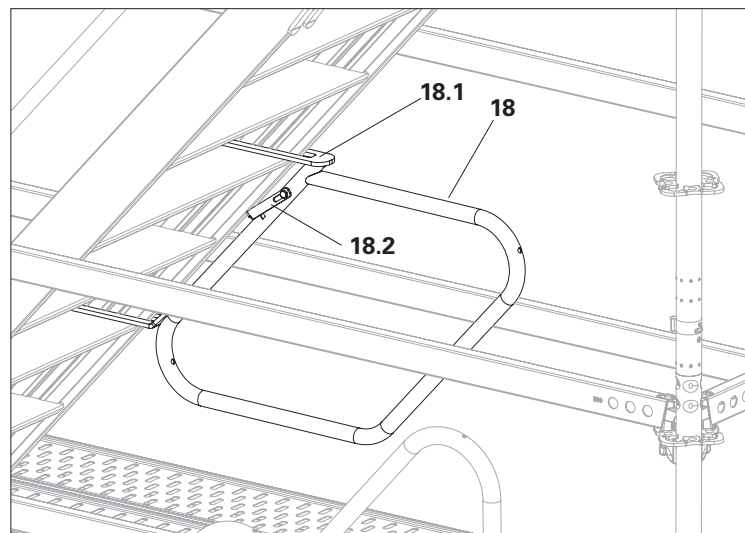

Fig. A4.02a

Steel decks

Components

19 Steel Deck UDG-2 25 x 300

Assembly

1. Fit 3 x Steel Decks UDG-2 (**19**) next to the Flex Stair. (Fig. A4.03)

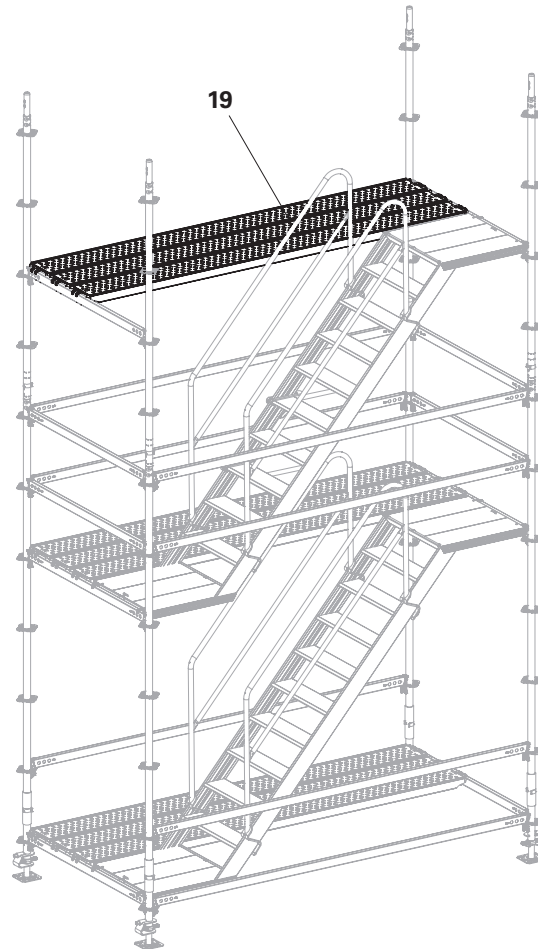

Fig. A4.03

Anchoring



- Ties do not transfer vertical loads!
- Anchorings should be installed progressively with the erection of the scaffolding.
- Fix with eyebolts or equivalent connection.
- The load-bearing capacity of the fixing material between the wall ties and the anchoring base must be verified by the customer for the tie loads in Section "A11 Ties, tie forces" on page 42.
- The first tie position should be established at a height of 4.0 m. For the other tie positions, see the tie patterns in the tables (Tab. A11.01).
- Each tie position consists of a short tie and a triangulated tie.
- The anchoring can be fitted in a mirror-inverted manner.

Short tie

-
- 31** Wall Tie UWT 45
 - 33** Standard Coupler RA 48/48
-

Assembly

1. Fix Wall Ties UWT 45 (**31**) to the wall, e.g. with eyebolts and dowels, or equivalent connection.
2. Fasten the Standard Coupler RA 48/48 (**33**) to the inner leg with Wall Tie UWT 45 (**31**). (Fig. A4.04)

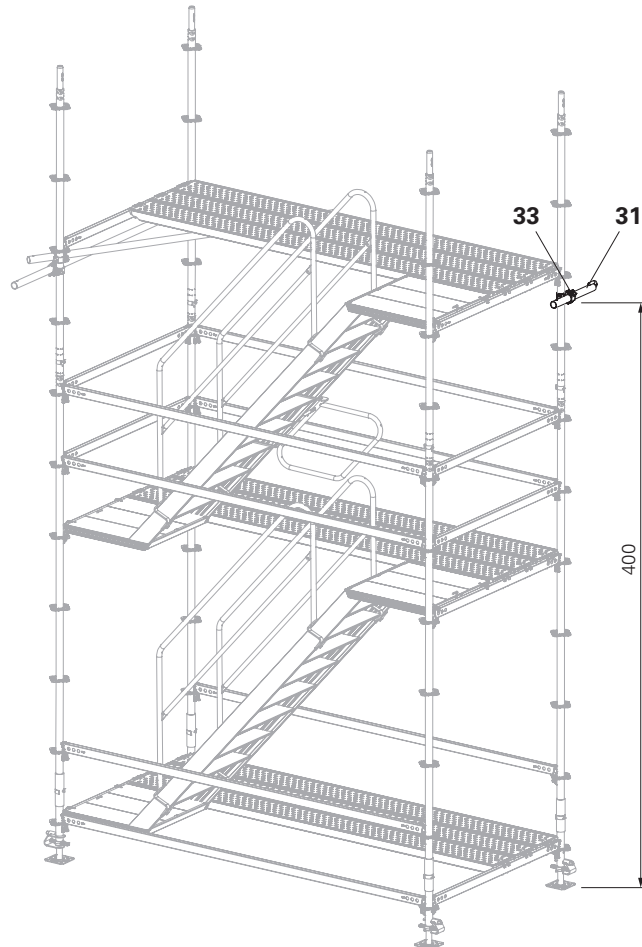

Fig. A4.04

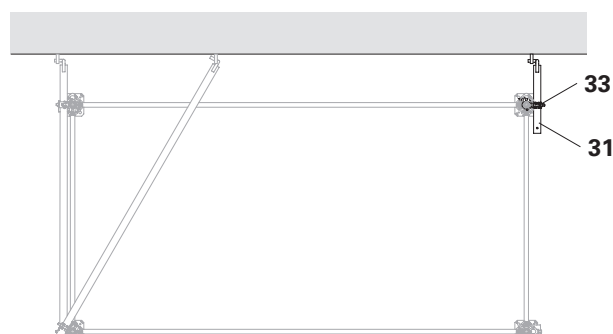

Fig. A4.04a

Triangulated tie

Components

- 30** Wall Tie UWT 220
- 33** Standard Coupler RA 48/48

Assembly

1. Fix the first Wall Tie UWT 220 (**30**) to the inner and outer Standards UVR-2 with Standard Couplers NK 48/48 (**33**).
2. Fix the second Wall Tie UWT 220 (**30a**) to the outer Standard UVR-2 with Standard Coupler RA 48/48 (**33**).
3. Fix Wall Ties to the wall, e.g. with eyebolts and dowels, or equivalent connection. (Fig. A4.05)



Fit the tie on the outside if possible. This reduces interference points in the traffic area.

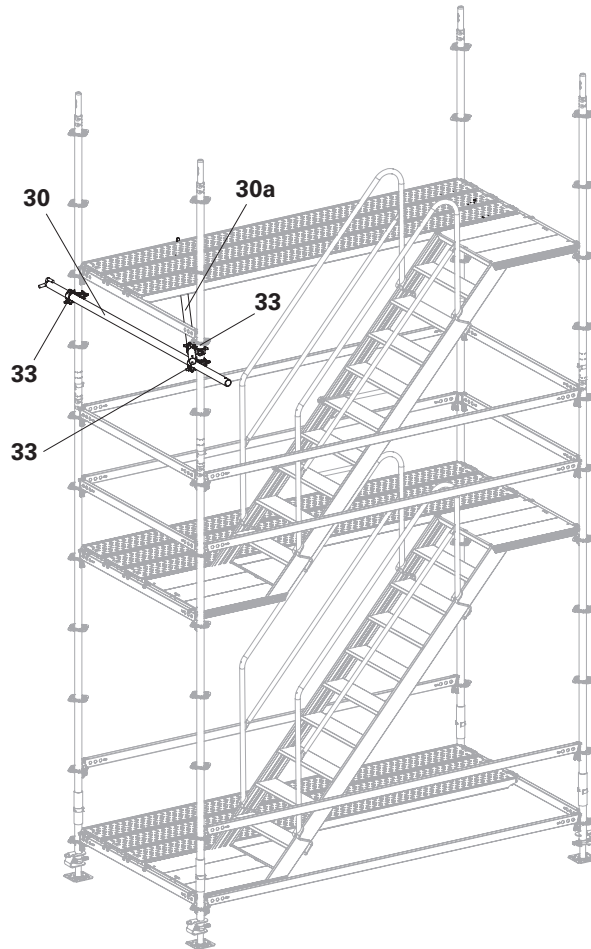

Fig. A4.05

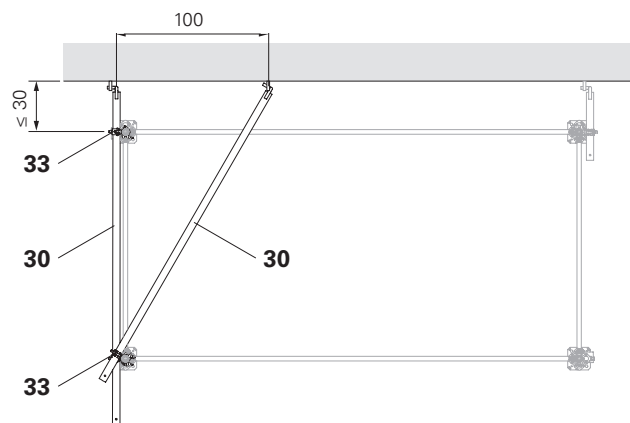

Fig. A4.05a

Lateral protection

Components

- 3** Horizontal Ledger UH-2 300
- 5** Horizontal Ledger UH-2 150

1. Fit 4 x Horizontal Ledgers UH-2 150 (**5**) and 4 x Horizontal Ledgers UH-2 300 (**3**). Hammer all wedges into place. (Fig. A4.06)



The Horizontal Ledgers UH-2 150 (**5a**) following installation of the Flex Stair on the next level. (Fig. A4.06)
Set up additional staircases according to this Section "A4 Other levels" on page 24 ff.

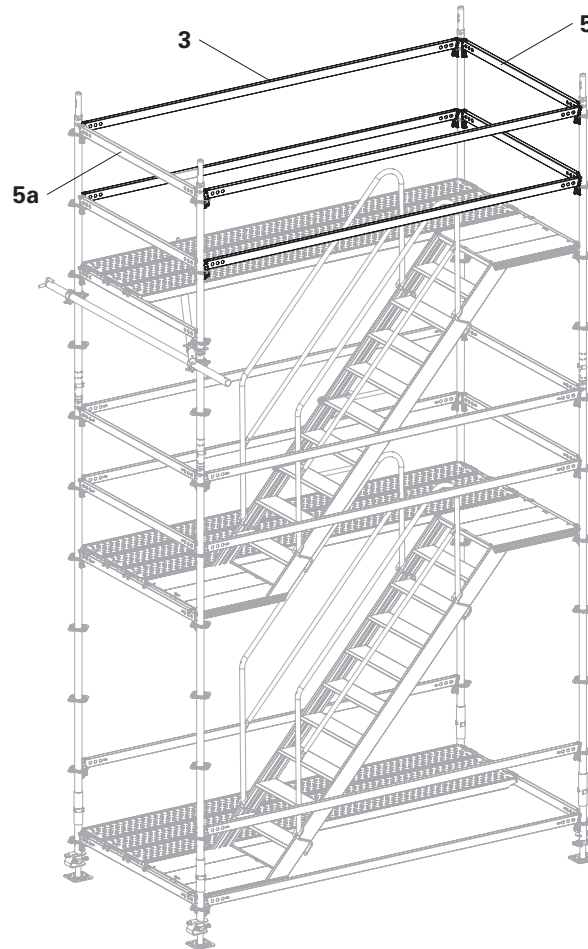

Fig. A4.06

The uppermost level is provided with an additional guardrail as anti-fall protection for accessing the building.

Components

3	Horizontal Ledger UH-2 300
4	Horizontal Ledger UH-2 200
5	Horizontal Ledger UH-2 150
6	Horizontal Ledger UH-2 75
10	Standard UVR-2 100
12	Standard UVR-2 200
15	Flex Stair UAS-2 75 x 300/200
17	Stair Guardrail UAG
18	Stair Guardrail UAH-2
19	Steel Deck UDG-2 25 x 300
24	Ledger-to-Ledger Coupler UHA-2
25	UH Spigot-2

Assembly

1. As with the installation of an additional level, fit Standards UVR-2 (**12**) and connect them with horizontal ledgers (**5**).
2. Flex Stair UAS-2 (**15**).
3. Fit a Stair Guardrail UAG (**17**) on the outside of the stair.
4. Fit Stair Guardrail UAH-2 (**18**) onto the rear side of the staircase (Fig. A5.01)
5. Fit one Ledger-to-Ledger Coupler UHA-2 (**24**) in the centre of each of the two Horizontal Ledgers UH-2 150 (**5**).
6. Fit a Horizontal Ledger UH-2 300 (**3**) onto the ledger-to-ledge couplers.
7. Fit a UH-Spigot-2 (**25**) onto the horizontal ledger at a distance of 1 m. (Fig. A5.02)

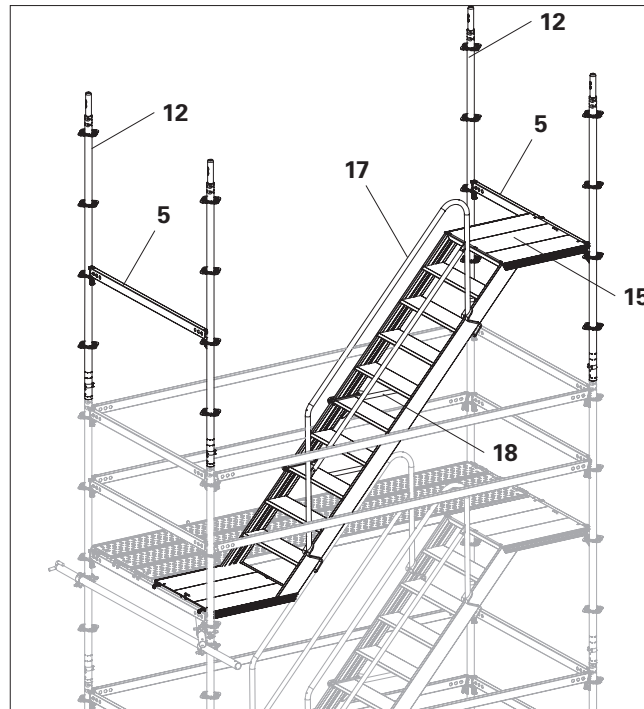

Fig. A5.01

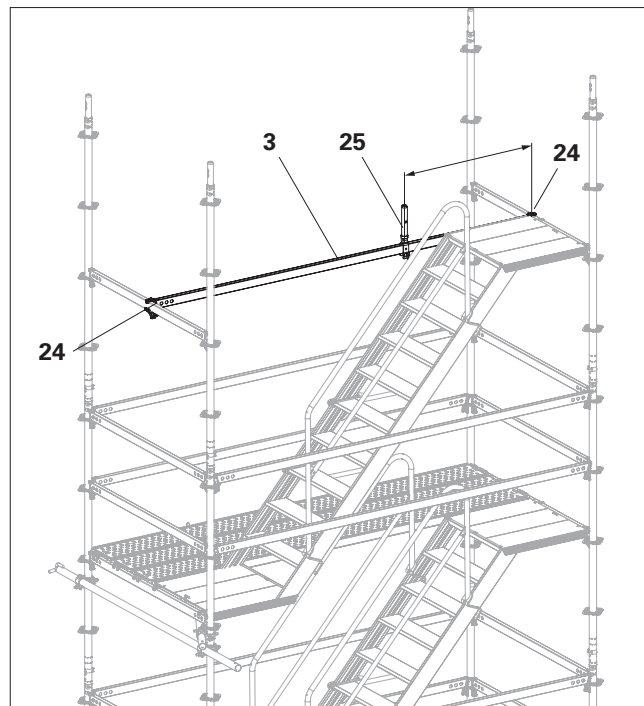

Fig. A5.02

A5 Uppermost level

8. Fit a Standard UVR-2 100 (**10**) or Top Standard UVH-2 100 onto the UH-Spigot-2.
 9. Fit Steel Decks UDG-2 25 x 300 (**19**) onto the uppermost level.
 10. Fit a Stair Guardrail UAG (**17a**) onto the inside of the stair.
- (Fig. A5.03)



Internal guardrails (**17a**) are not always required. Observe country-specific regulations.

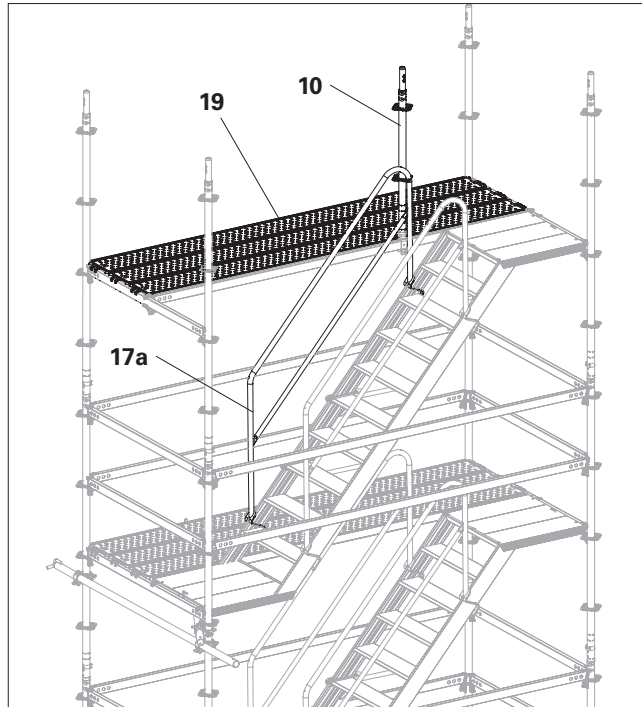

Fig. A5.03

11. Fit Horizontal Ledgers UH-2 300 (**3**) and UH-2 150 (**5 + 5a**).
12. Fit 2 x Ledger-to-Ledger Couplers UHA-2 (**24**) centrally on the 2 Horizontal Ledgers UH-2 150 (**5a**).
13. Fit 2 x Horizontal Ledgers UH-2 200 (**4**) onto the ledger-to-ledge couplers and standard.
14. For bracing, fit a Horizontal Ledger UH-2 75 (**6**) between the horizontal ledgers (**3 + 4**) using ledger-to-ledge couplers (**24a**). (Fig. A5.04)



Leave the horizontal ledger (**3b**) in place until a safe transition can be guaranteed.

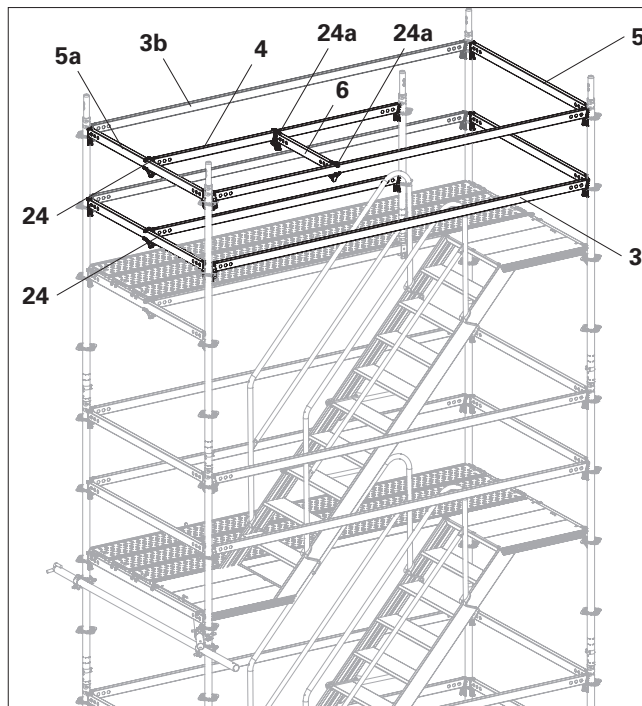

Fig. A5.04

For exit width 75 cm:

5. Pre-assemble two Horizontal Ledgers UH-2 25 (**8**) on a Standard UVR-2 100 (**10a**).
6. Hook the assembly (**8 + 10a**) with the horizontal ledgers (**8**) into the standard (**10**). Secure the wedges. (Fig. A5.05)

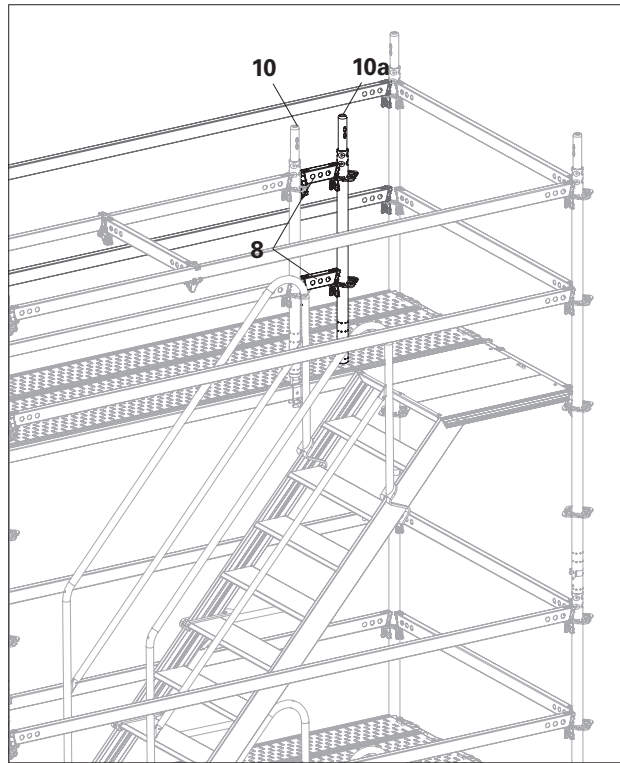

Fig. A5.05

A6 Intermediate access points

Intermediate access points can be installed on every second floor. (Fig. A6.03b)

Components

- 3** Horizontal Ledger UH-2 300
- 22** Ledger Brace UBL-2 300/200
alternatively:
- 32** Scaffolding tubes 48.3 x 3.2 mm
- 34** Swivel couplings AF 48/48

Measures on the wall side

- Move both Horizontal Ledgers UH-2 300 (**3**) up and down.
- Fit Ledger Braces UBL-2 (**22**) onto the floors above and below.
- Fit additional horizontal ledgers (**3a**) onto the floors above and below. (Fig. A6.01 + Fig. A6.02)
- Fit additional ties, see Section "Tie positions – installation heights" on page 42.

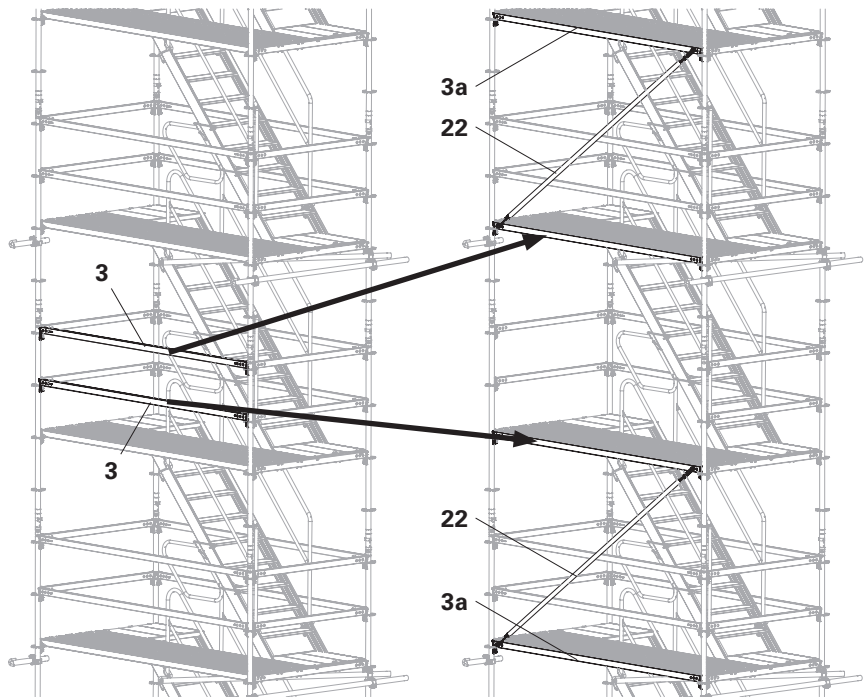

Fig. A6.01

Fig. A6.02

Heights of 52 m and above

- Fit Ledger Braces UBL-2 in the lower levels in accordance with Section "Tie positions – installation heights" on page 42. (Fig. A6.04)
- If exit points are required at the lower levels, then exit via the front sides.

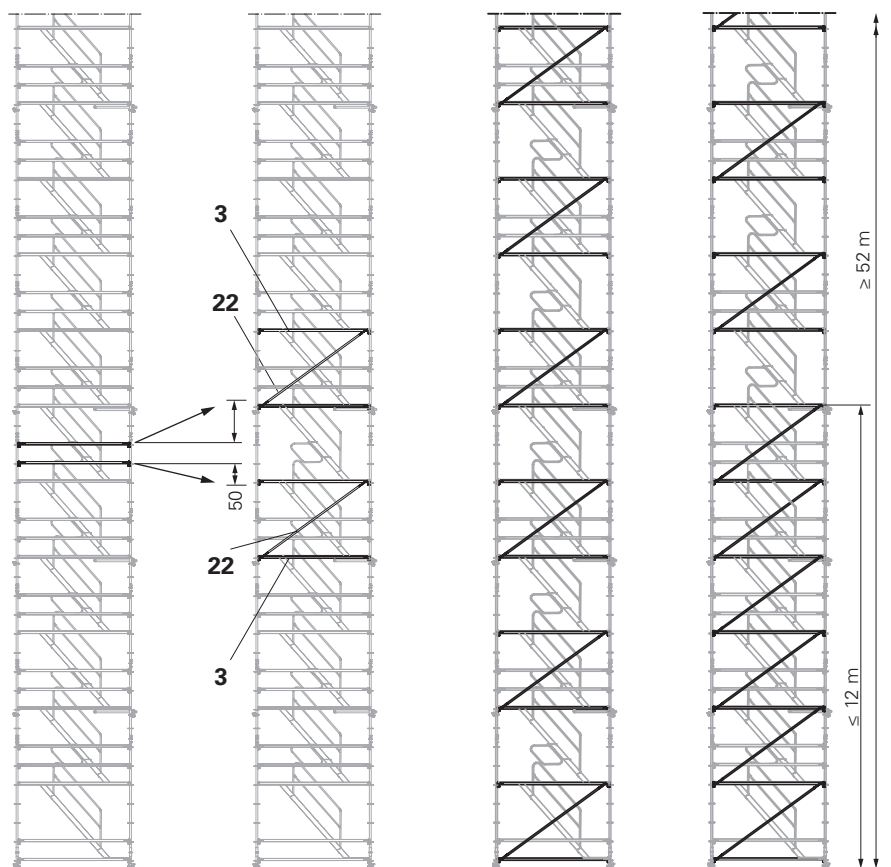

Fig. A6.03

Fig. A6.03a

Fig. A6.03b

Fig. A6.04

Height adjustment

via front-side console bracket



- Max. height of the stair tower: 30 m.
- Permissible load on the console brackets: 2 kN/m².
- Exit point via front-side console brackets. Height adjustment possible with 4 versions:
 - UAS-2 75 x 150/100 S +1.0 m
 - UAS-2 75 x 150/100 T -1.0 m
 - UAS-2 75 x 150/50 S +0.5 m
 - UAS-2 75 x 150/50 T -0.5 m
- Depicted: Flex Stair with +1.0 m
- Tie spacing
 - 4 m up to height ≤ 12 m
 - 8 m for heights > 12 m
 - Anchoring must always be installed above a front-sided access point, e.g. front-sided access point at a height of 28 m with a total height of 30 m.
- Ledger Braces UBL-2
 - none up to height ≤ 12 m
 - every 8 m for heights > 12 m.

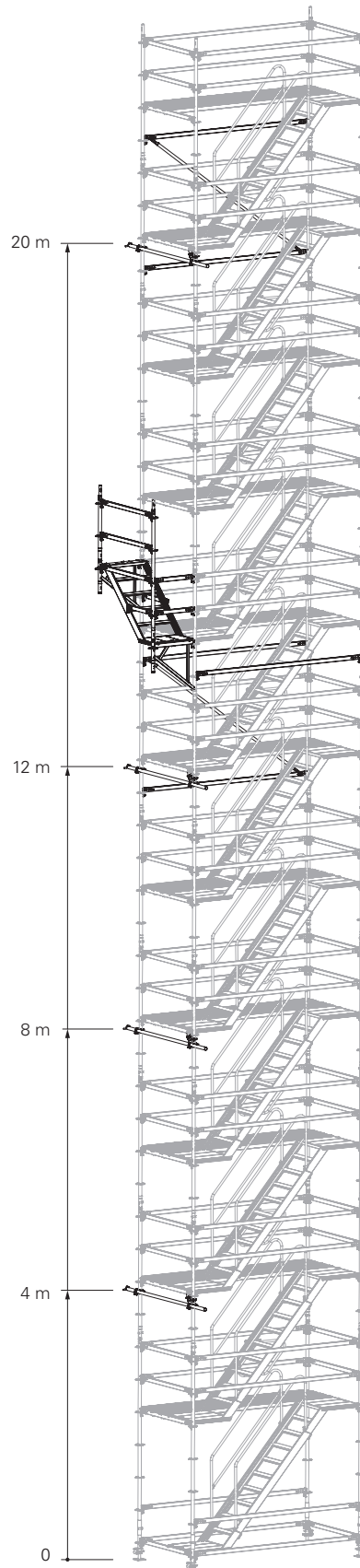

Fig. A7.01

Components

- 3** Horizontal Ledger UH-2 300
- 5** Horizontal Ledger UH-2 150
- 6** Horizontal Ledger UH-2 75
- 10** Standard UVR-2 100
- 11** Standard UVR-2 150
- 12** Standard UVR-2 200
- 16** Flex Stair UAS 75 x 150/100 S
- 20** Console Bracket ECM 75
- 25** UH Spigot-2



Leave the lateral protection (**6a**) in place until after the front-side exit point has been fully assembled.

Exit point with height adjustment +100 cm:

Assembly

From a secured position:

1. Fit Console Brackets ECM (**20**) – 2 x.
2. Fit Standards UVR-2 (**12+10**).
3. Add Horizontal Ledger UH-2 300(**3**) 50 cm beneath the suspension of the console bracket, if not available. (Fig. A7.02)
4. Attach the flex stair (**16**). (Fig. A7.03)



Both lift locks (**16.1**) must fall under the horizontal ledgers. If they do not, lift the component slightly and let it drop into position or operate the lift lock manually.

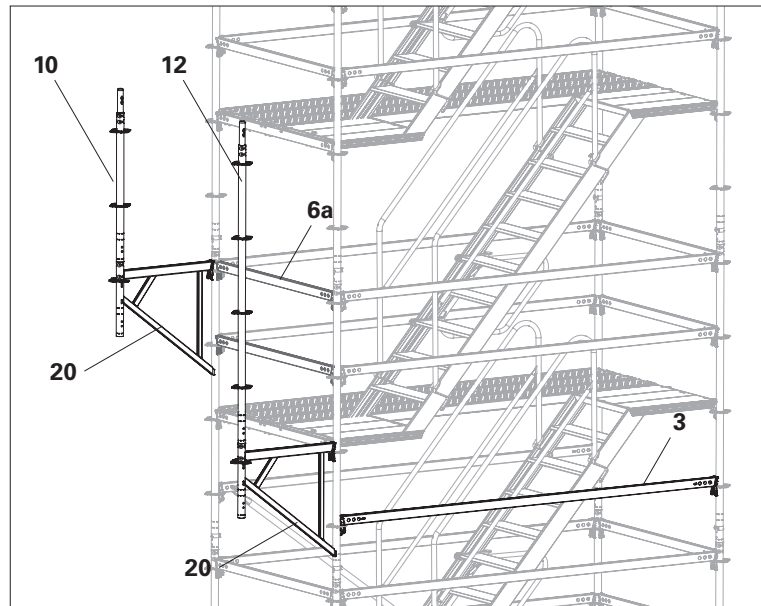

Fig. A7.02

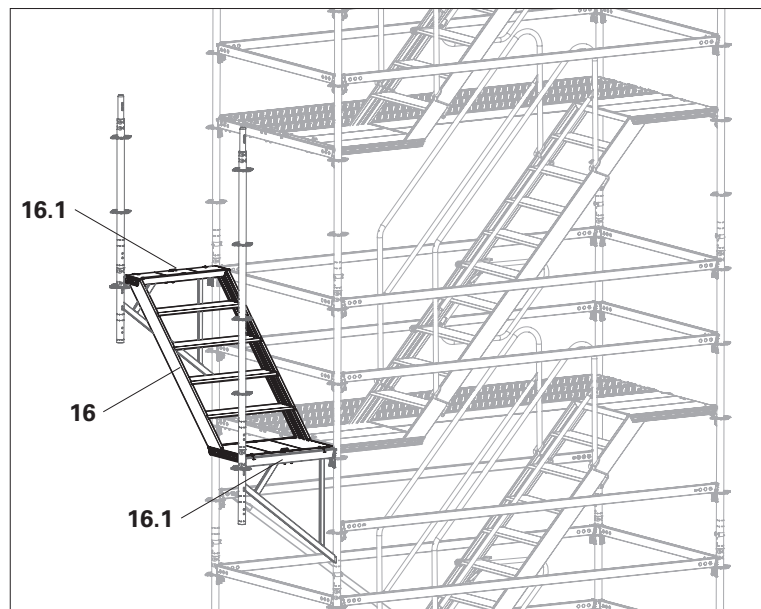

Fig. A7.03

5. Fit Horizontal Ledger UH-2 150 (5) 1 x + UH-2 75 (6) 4 x as lateral protection.
6. Remove Horizontal Ledger UH-2 150 from the base scaffold and fit it at the exit point as lateral protection (5a). (Fig. A7.04)

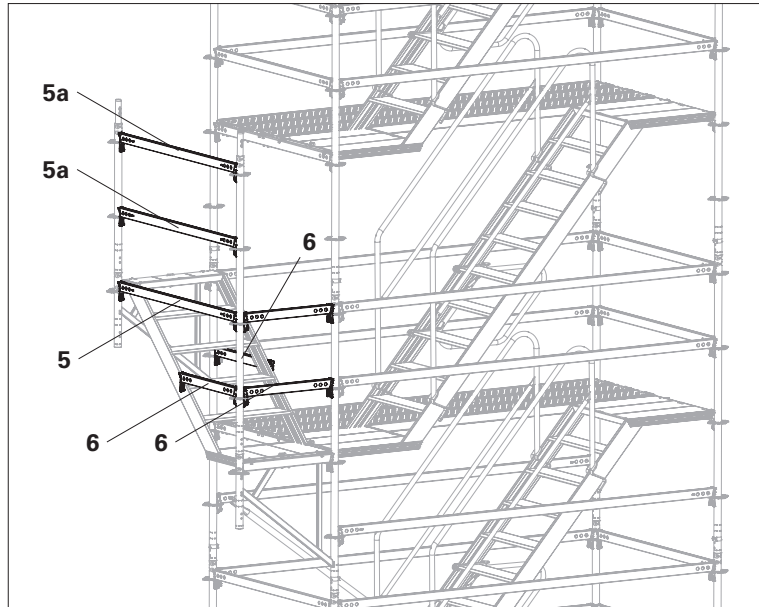

Fig. A7.04

Exit point with height adjustment -50 cm:

Assembly:

In addition to previous section, fit the following:

1. Fit a UH-Spigot-2 (25) onto the horizontal ledger.
2. Fit a Standard UVR-2 100 (10).
3. Fit 2 x Horizontal Ledgers UH-2 75 (6) as lateral protection. (Fig. A7.05)

Mirror image of structure

The mirror-image structure is permissible and built analogously.

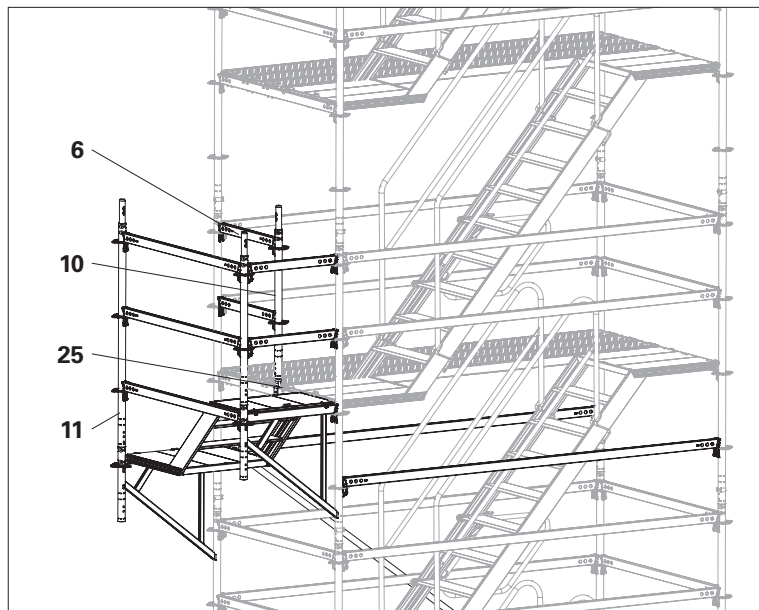

Fig. A7.05

Components

- 3** Horizontal Ledger UH-2 300
- 23** Ledger Brace UBL-2 300/200

Fitting the bracing

1. Fit Horizontal Ledger UH-2 300 (**3**) if required.
2. Install ledger braces (**23**) on the inner side immediately above the next highest anchoring point. Add horizontal ledgers as required.
3. Install ledger braces (**23a**) on the inner side immediately above all anchoring points positioned below. Add horizontal ledgers as required. (Fig. B5.04)

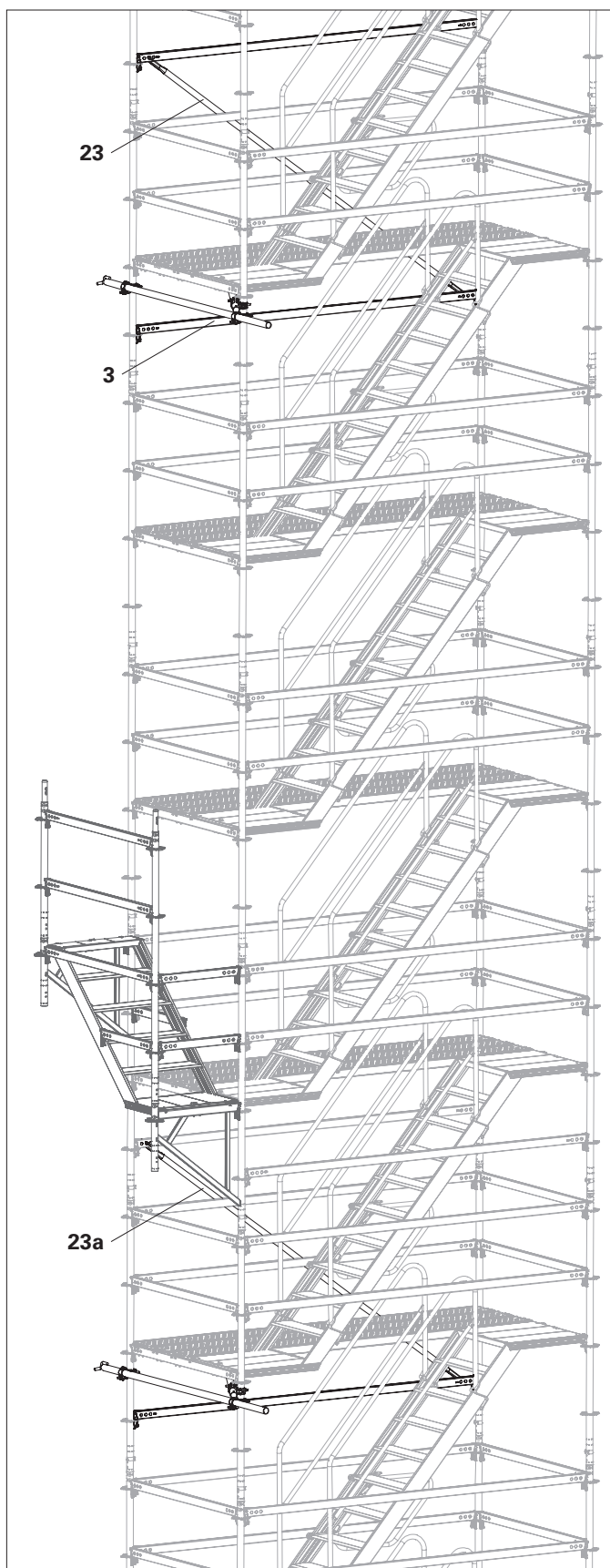

Fig. A7.06

Extended lateral protection

Depending on national regulations, further horizontal ledgers may be required as lateral protection.

Components

- 3 Horizontal Ledger UH-2 300
- 5 Horizontal Ledger UH-2 150

Assembly

Install additional horizontal ledgers progressively with the assembly of the stair tower.

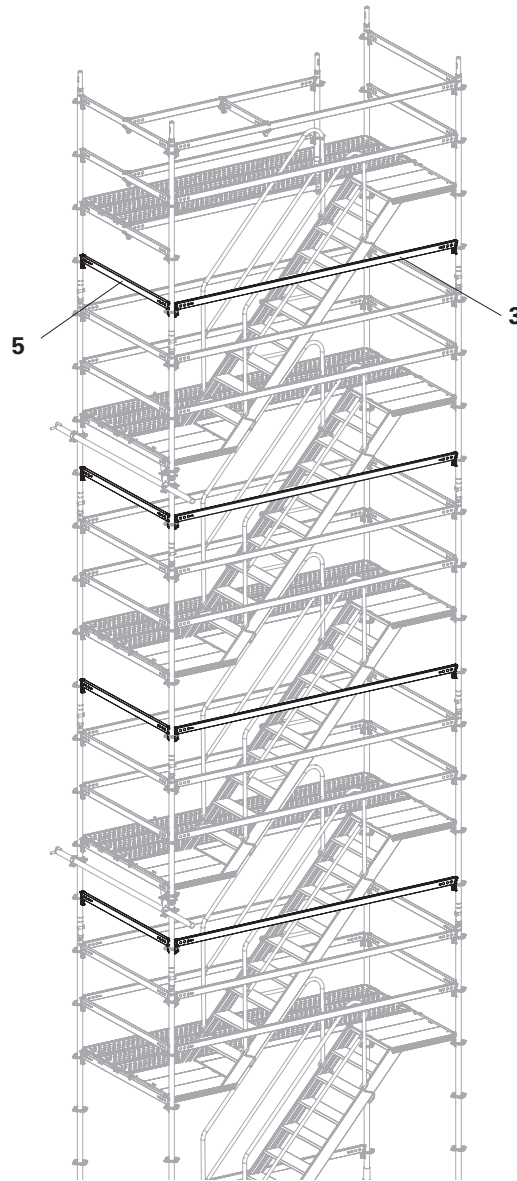

Fig. A7.07

Refer to Instructions for Short
Lift systems to NASC SG4:15

Dismantling



The scaffolding contractor can also undertake other measures on the basis of his own risk assessment.

Standard sequence

- Dismantle from top to bottom, i.e. in the reverse order as shown in the assembly procedure.
- Remove the anchorings progressively along with the Flex Stair from top to bottom.
- In the event of work being interrupted, the top level should not extend more than 2.0 m beyond the highest tie positions.

Loads on Flex Stair UAS-2 and Steel Decks UDG

The permitted load for the flights of stairs is $p = 2.0 \text{ kN/m}^2$ (on landing platforms and steps).

Flight of stairs UAS 75x250/200
or UAS 75x300/200

$p = 2.0 \text{ kN/m}^2$

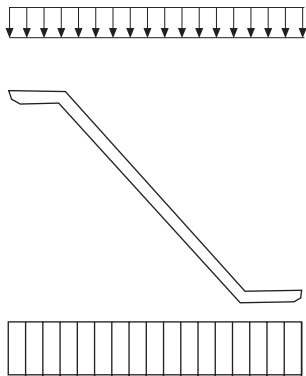

Loads on stair tower

A stair tower consists of several flights of stairs, which are arranged above one another like a tower.

The permissible load of the stair tower is $p = 2.0 \text{ kN/m}^2$ for a maximum length of 20 linear metres.

For stairs with a bay length of 3.0 m, approx. 3 levels are loaded (corresponds to a height of 6 m); for a bay length of 2.50 m, approx. 4 levels (corresponds to a height of 8 m).

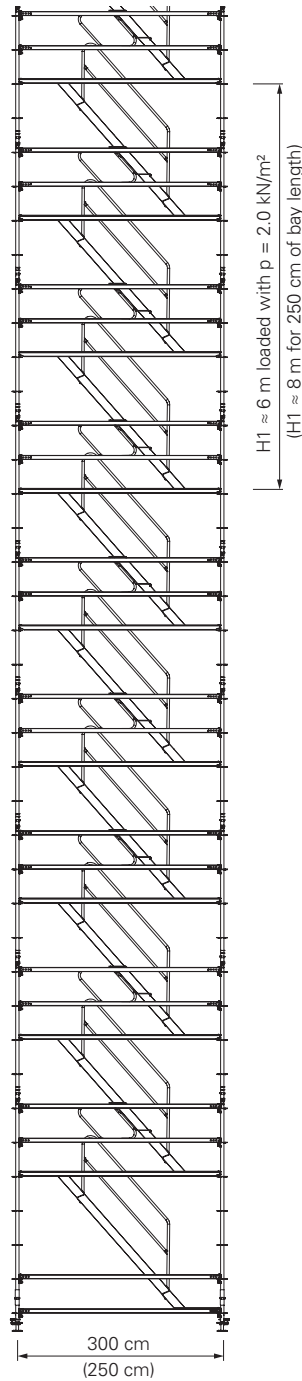
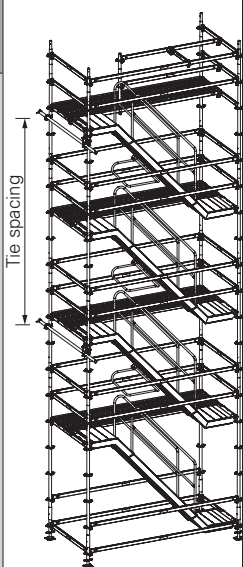

Fig. A9.01

Reaction forces of verticals

The reaction forces for the stair towers are given in the table and depend on the overall height and bay length respectively. (Tab. A10.01)

For the medium vertical loads, the permissible load was distributed evenly across all verticals. To determine the maximum leg loads, 75% of the permissible load was concentrated on one side of the scaffolding.

Tower height [m]	Foundation for complete tower		Foundation for individual verticals		Flex Stair with staircase units in the same direction
	medium vertical loads		max. vertical loads		
	Bay length 250 cm [kN]	Bay length 300 cm [kN]	Bay length 250 cm [kN]	Bay length 300 cm [kN]	
2.3	2.4	2.9	3.3	3.9	
4.3	4.7	5.5	6.5	7.6	
6.3	7.0	8.2	9.6	11.3	
8.3	9.2	9.5	12.7	13.0	
10.3	9.7	10.0	13.2	13.5	
12.3	10.3	10.6	13.8	14.1	
14.3	10.8	11.2	14.3	14.7	
16.3	11.3	11.7	14.8	15.2	
18.3	11.8	12.3	15.3	15.8	
20.3	12.3	12.9	15.8	16.4	
22.3	12.8	13.4	16.3	16.9	
24.3	13.3	14.0	16.8	17.5	
26.3	13.8	14.6	17.3	18.1	
28.3	14.4	15.1	17.9	18.6	
30.3	14.9	15.7	18.4	19.2	
32.3	15.4	16.3	18.9	19.8	
34.3	15.9	16.8	19.4	20.3	
36.3	16.4	17.4	19.9	20.9	
38.3	16.9	18.0	20.4	21.5	
40.3	17.4	18.5	20.9	22.0	
42.3	17.9	19.1	21.4	22.6	
44.3	18.5	19.7	22.0	23.2	
46.3	19.0	20.2	22.5	23.7	
48.3	19.5	20.8	23.0	24.3	
50.3	20.0	21.4	23.5	24.9	
52.3	20.5	22.0	24.0	25.5	
54.3	21.0	22.5	24.5	26.0	
56.3	21.5	23.1	25.0	26.6	
58.3	22.0	23.7	25.5	27.2	
60.3	22.6	24.2	26.1	27.7	
62.3	23.1	24.8	26.6	28.3	
64.3	23.6	25.4	27.1	28.9	
66.3	24.1	25.9	27.6	29.4	

Tab. A10.01

Tie positions – installation heights

		Flex Stair with staircase units in the same direction														
Structure height [m]	Number of ties	Tie installation height [m]														
		2 – 6	1													
8 – 14	2															
16 – 22	3															
24 – 30	5															
Tie forces [kN]	A	6.8	3.4	3.5	7.4	8.0	8.4									
	A _{II}	1.9	1.0	1.0	2.1	2.2	2.4									
	A _⊥	6.5	3.2	3.4	7.1	7.6	8.1									
	B	7.4	3.7	3.9	8.1	8.7	9.2									
	B _{II}	3.6	1.8	1.9	3.9	4.2	4.5									
	B _⊥	6.5	3.2	3.4	7.1	7.6	8.1									
	C	2.9	1.5	1.5	3.2	3.4	3.6									
		6 m tie spacing														
32 – 36	7	4	8	12	16	22	28	34								
38 – 40	8	4	8	12	16	20	26	32	38							
42 – 44	9	4	8	12	16	20	24	30	36	42						
46 – 48	10	4	8	12	16	20	24	28	34	40	46					
50 – 52	11	4	8	12	16	20	24	28	32	38	44	50				
54 – 56	12	4	8	12	16	20	24	28	32	36	42	48	54			
58 – 60	13	4	8	12	16	20	24	28	32	36	40	46	52	58		
62 – 64	14	4	8	12	16	20	24	28	32	36	40	44	50	56	62	
– 66	15	4	8	12	16	20	24	28	32	36	40	44	48	54	60	66

Tab. A11.01

Ledger Braces UBL-2 are required on the inside and outside of the long sides.

Tension and compression-proof anchoring

Tie heights are measured without the length of the jack extension.

Height up to 30 m

Install the first tie at 4.0 m, then at spacings of 8.0 m. Intermediate ties may be necessary to an extent at 8.0 m.

Height from 32 m

Install the first tie at 4.0 m, then every 4.0 m in the lower area (marked in grey), and then every 6.0 m.

Height from 52 m

Ledger Braces UBL-2 (or scaffolding tubes 48.3 x 3.2 and swivel couplings AF 48/48) are required on the lower levels on the long sides inside and outside:

Height of 52 – 56 m: levels 1 to 2

Height of 58 – 60 m: levels 1 to 4

Height of 62 – 66 m: levels 1 to 6

Top level

May be cantilevered to a maximum of 2.0 m!

Intermediate access on every 2nd floor

Install ties progressively every 4.0 m; braces are required on the lower levels as for towers more than 52 m high.

Example: Stair with a height of 32 – 36 m

- 32 m: last tie at 32 m
- 34 m: last tie at 34 m
- 36 m: last tie at 34 m

Tie forces

The tie forces have been calculated for an unclad stair tower in front of an open facade (60% openings). A wind load with the following dynamic pressures has been taken into account for the visible areas of the scaffold:

Load combination - service condition

Constant dynamic pressure:
 $q = 0.20 \text{ kN/m}^2$.

Load combination - max. wind load

Dynamic pressure changing with height:

- $q_1 = 0.60 \text{ kN/m}^2$ (at 0 m)
- $q_2 = 0.77 \text{ kN/m}^2$ (at 24 m) and
- $q_3 = 1.05 \text{ kN/m}^2$ (at 100 m)

with service life factor 0.7.

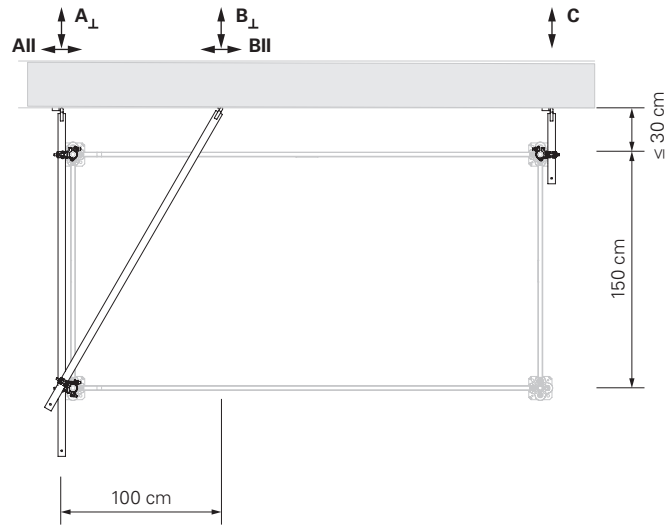

Fig. A11.01

With the assumed wind loads, this results in the following maximum tie forces for the various assembly heights and tie spacings (see also Tab. A11.01):

Maximum tie forces for 8 m spacing

(Height $\leq 30 \text{ m}$)

- Triangulated tie: max. A = 8.4 kN
- divided into: $A_{||} = 2.4 \text{ kN}$
 $A_{\perp} = 8.1 \text{ kN}$
- max. B = 9.2 kN
- divided into: $B_{||} = 4.5 \text{ kN}$
 $B_{\perp} = 8.1 \text{ kN}$
- Short wall tie: max. C = 3.6 kN

Maximum tie forces for 6 m spacing

(Height $\leq 66 \text{ m}$)

- Triangulated tie: max. A = 7.4 kN
- divided into: $A_{||} = 2.1 \text{ kN}$
 $A_{\perp} = 7.1 \text{ kN}$
- max. B = 8.2 kN
- divided into: $B_{||} = 4.0 \text{ kN}$
 $B_{\perp} = 7.1 \text{ kN}$
- Short wall tie: max. C = 3.2 kN

Maximum tie forces for 4 m spacing

(Height $\leq 66 \text{ m}$)

- Triangulated tie: max. A = 4.7 kN
- divided into: $A_{||} = 1.4 \text{ kN}$
 $A_{\perp} = 4.7 \text{ kN}$
- max. B = 5.4 kN
- divided into: $B_{||} = 2.6 \text{ kN}$
 $B_{\perp} = 4.7 \text{ kN}$
- Short wall tie: max. C = 2.1 kN

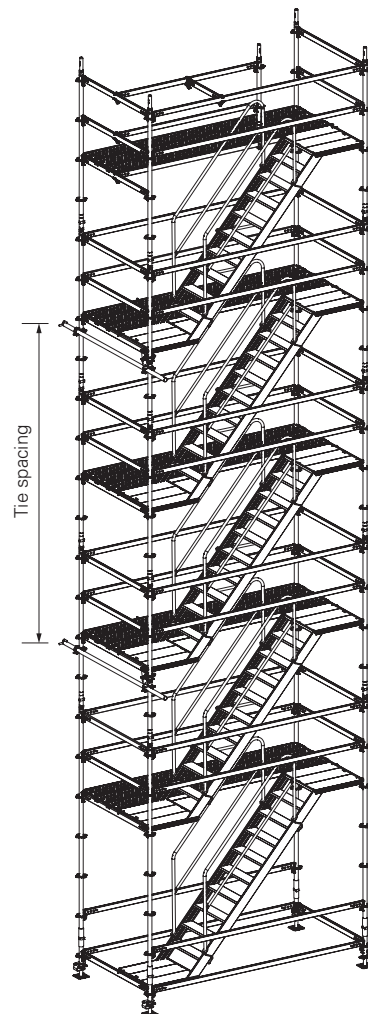

Fig. A11.02

General



- For basic information on the assembly of PERI UP, see the assembly instructions for PERI UP Scaffolding Kit core components.
- 2 people are required to carry out the assembly of the stair elements.

Flex Stair with staircase units in the same direction

With anchoring and access to the building.

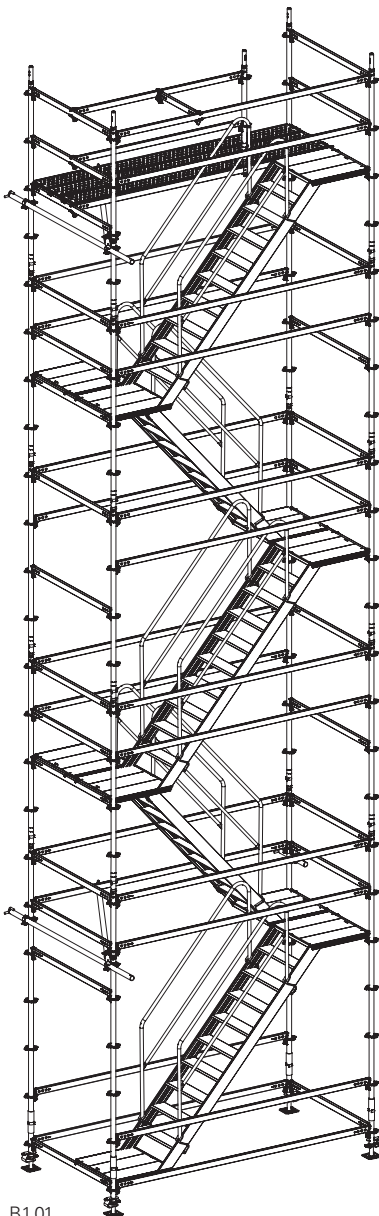
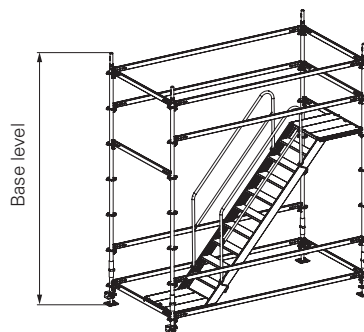
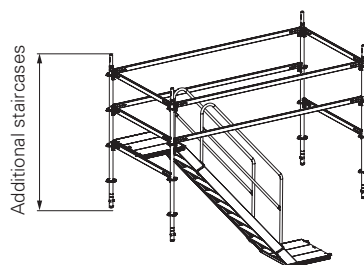
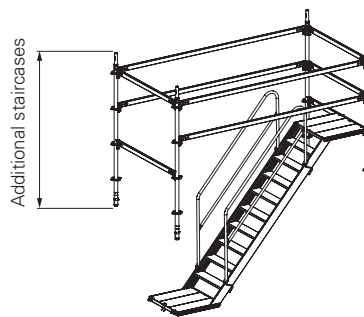
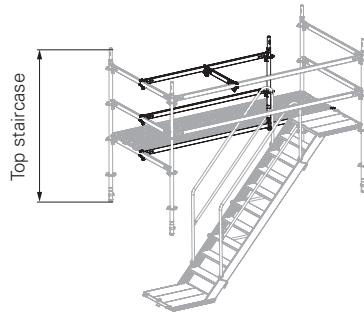

Fig. B1.01

General

The PERI UP Flex Stair 75 system can be assembled in bay lengths of 250 cm or 300 cm

The following sections show the assembly process for a bay length of 300 cm.

The figures apply accordingly to the bay length of 250 cm.

Modifications for bay length 250 cm

Replace or reduce the following components:

Horizontal Ledger UH-2 300 **(3)**
→ Horizontal Ledger UH-2 250

Horizontal Ledger UH-2 200 **(4)**
→ Horizontal Ledger UH-2 150

Flex Stair UAS-2 75 x 300/200 **(15)**
→ Flex Stair UAS-2 75x250/200

Steel Deck UDG-2 25x300 **(19)**
→ Steel Deck UDG-2 25x250

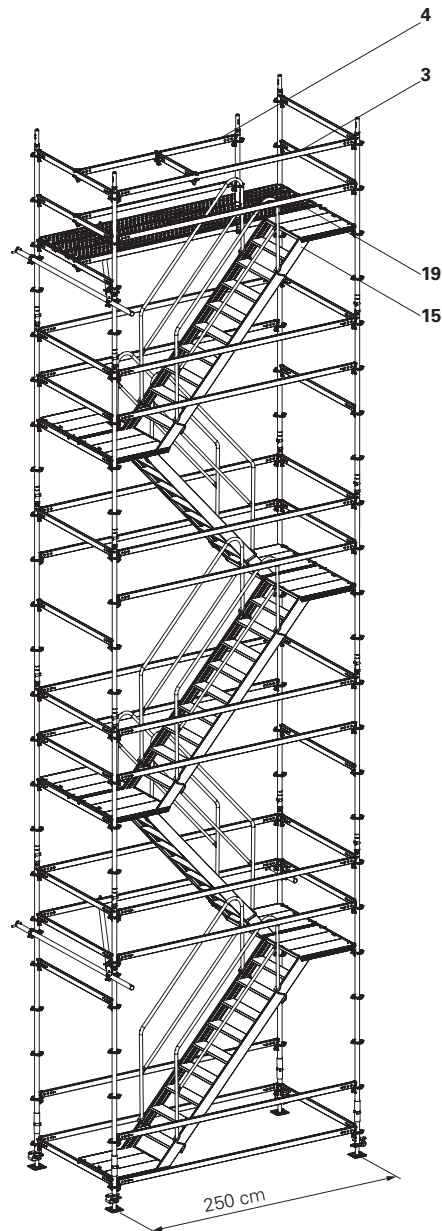

Fig. B2.01

Refer to Instructions for Short Lift systems to NASC SG4:15

Base level

Components

- 1 Base Spindle UJB
- 2 Base Standard UVB 25
- 3 Horizontal Ledger UH-2 300
- 5 Horizontal Ledger UH-2 150

Assembly

1. Assemble frame.
Distance to building ≤ 30 cm.
(Fig. B3.01)
2. Horizontally align frame by adjusting the Base Spindles UJB (1). Spindle extension:
– for assembly heights up to 36 m:
Lsp ≤ 30 cm,
– for assembly heights over 36 m:
Lsp ≤ 20 cm. (Fig. B3.02)
3. Secure wedges on all ledgers using a 500 g hammer. (Fig. B3.04 – Fig. B3.06)
4. Fit Steel Decks UDG-2 (19) in the base level as an installation aid. (Fig. B3.03 + Fig. B3.03a)



- All ledgers must be at 90° to one another. (Fig. B3.02)
- For crane relocation purposes, spindle out the Base Spindle UJB by at least 17 cm. This is the only way to ensure a tension-proof connection between the Base Standard UVB and the Standard UVR-2 with locking pins.



Install base standards and standards with holes lined up in the same direction. This procedure allows the tubes to be joined with locking pins for crane use at any time.

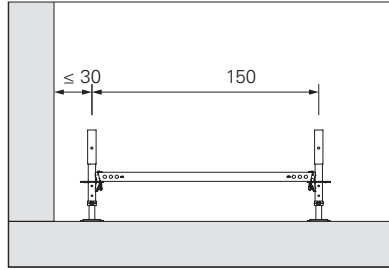

Fig. B3.01

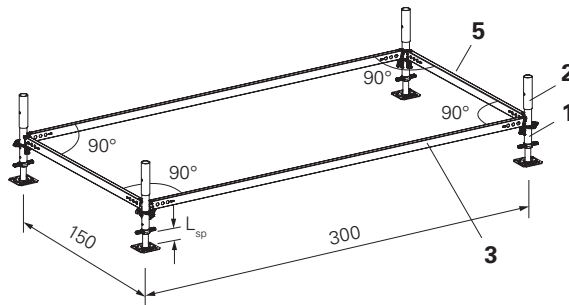

Fig. B3.02

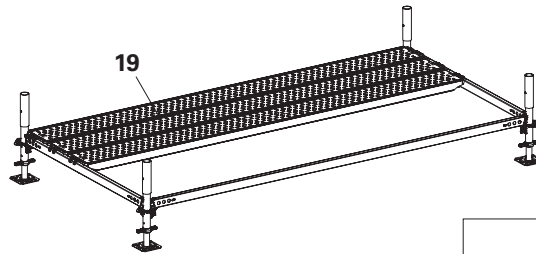

Fig. B3.03

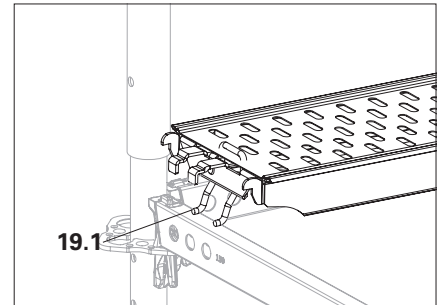

Fig. B3.03a

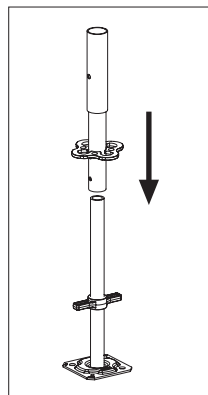

Fig. B3.04

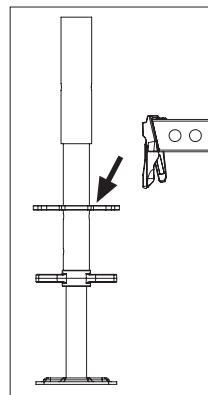

Fig. B3.05

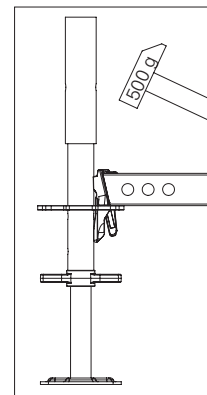

Fig. B3.06

Standards and ledgers

Components

- 3** Horizontal Ledger UH-2 300
- 5** Horizontal Ledger UH-2 150
- 13** Standard UVR-2 300
- 35** Spindle Locking UJS

Assembly

1. Insert Standards UVR-2 (**13**).
2. Attach Horizontal Ledgers UH-2 150 (**5**) and secure wedges with hammer blow.
3. Attach Horizontal Ledgers UH-2 300 (**3**) and secure wedges with hammer blow. (Fig. B3.07)
4. If movement by crane is envisaged, fit Spindle Locking UJS (**35**). (Fig. B3.07a)

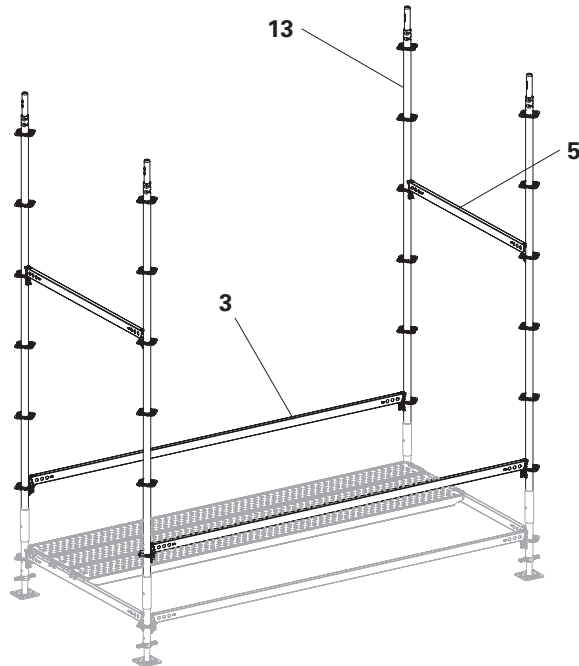

Fig. B3.07

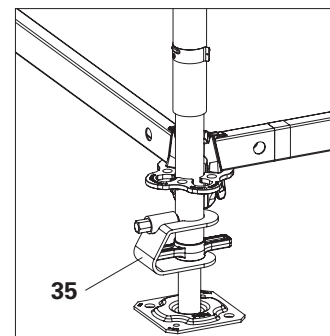

Fig. B3.07a

Flex Stair and guardrail

Components

- 15** Flex Stair UAS-2 75 x 300/200
- 17** Stair Guardrail UAG
- 19** Steel Deck UDG-2 25 x 300

Assembly

1. Attach the Flex Stair UAS-2 (**15**) to the upper horizontal ledger (**5a**) first, then to the lower horizontal ledger (**5b**). (Fig. B3.08 + Fig. B3.08a)
2. Fit 2 x Stair Guardrails UAG (**17+17a**) with upper suspension (**160.1**) above the second step from the top. (Fig. B3.08 + Fig. B3.08b)



All lift locks (**15.1+19.1**) must drop beneath the horizontal ledgers. If they do not, lift the component slightly and let it drop into position or operate the lift lock manually.



- If the scaffolding bays are larger, then the installation width must be limited to the dimensions of the stairs in question. Limit the installation width to 75 cm to prevent lateral shifting. The UH Spigot-2, for example, would be suitable for this purpose.
- Alternatively, leave steel decks in the base level as an additional standing surface.
- Internal guardrails (**17a**) are not always required. Observe country-specific regulations.



The inside railing can be mounted one level higher if the country-specific regulations allow for this. This means that the handrail will already be at hand height from the landing platform level when accessing from above. (Fig. B3.08c)

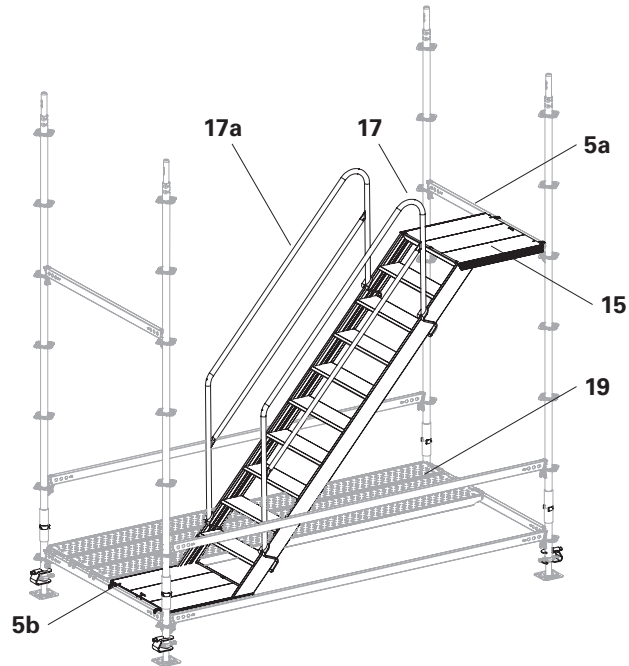

Fig. B3.08

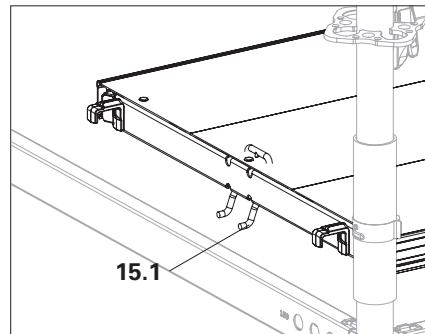

Fig. B3.08a

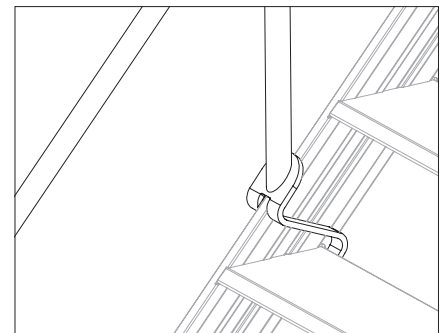

Fig. B3.08b

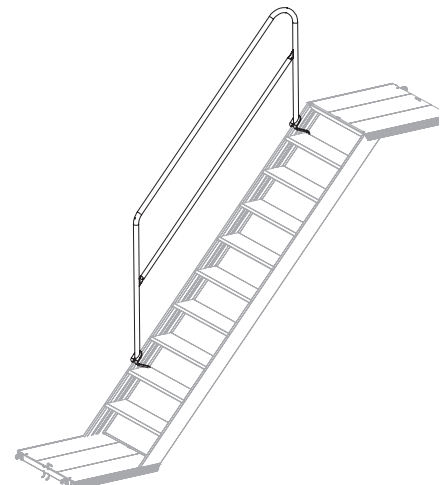

Fig. B3.08c

Auxiliary decks and ledgers

Components

- 3** Horizontal Ledger UH-2 300
- 5** Horizontal Ledger UH-2 150
- 26** Steel Deck UDG-2 25 x 150

Assembly decks

To install additional flights of stairs, 2 sets of auxiliary decks are required in each case, consisting of
2 x Steel Decks UDG-2 25 x 150,
1 x Passage Deck UAW
1 x Ladder UAF 200

Assembly

1. Place steel decks (**26**) on Horizontal Ledger UH-2 300 (**3**).
2. From the position of the Flex Stair (**15**) and steel decks (**26**), fit 3 x Horizontal Ledgers UH-2 300 (**3**) and 2 x UH-2 150 (**5**). (Fig. B3.09)

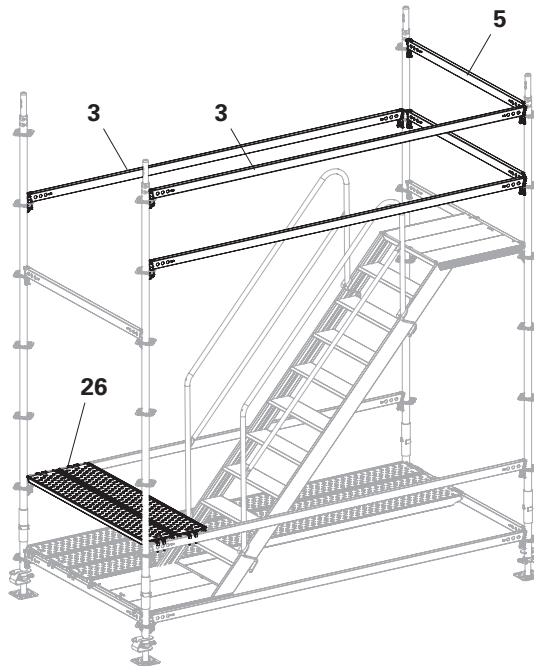

Fig. B3.09

Passage deck and verticals



Warning

Throughout the entire assembly process, there is a risk of falling due to the partial lack of lateral protection.

A fall can result in serious injuries or even death.

⇒ Use PPE to prevent falls.

Components

- 3** Horizontal Ledger UH-2 300
- 5** Horizontal Ledger UH-2 150
- 12** Standard UVR-2 200
- 27** Passage Deck UAW 75 x 150
- 28** Ladder UAF 200, Alu

Assembly

1. Fit the Passage Deck UAW 75 x 150 (**27**) onto the next intermediate guardrail level (**3**) with the flap opening outwards and attach the Ladder UAF 200 (**28**).
2. From the position of the ladder, fit the fourth Horizontal Ledger UH-2 300 (**3a**).
3. Insert Standards UVR-2 (**12**).
4. Fit Horizontal Ledgers UH-2 (**5**) and secure wedges with hammer blow. (Fig. B4.01)
5. If relocation by crane is envisaged, connect all verticals with locking pins D48/D57 (**36**) so that they are tension-proof. (Fig. B4.01a)

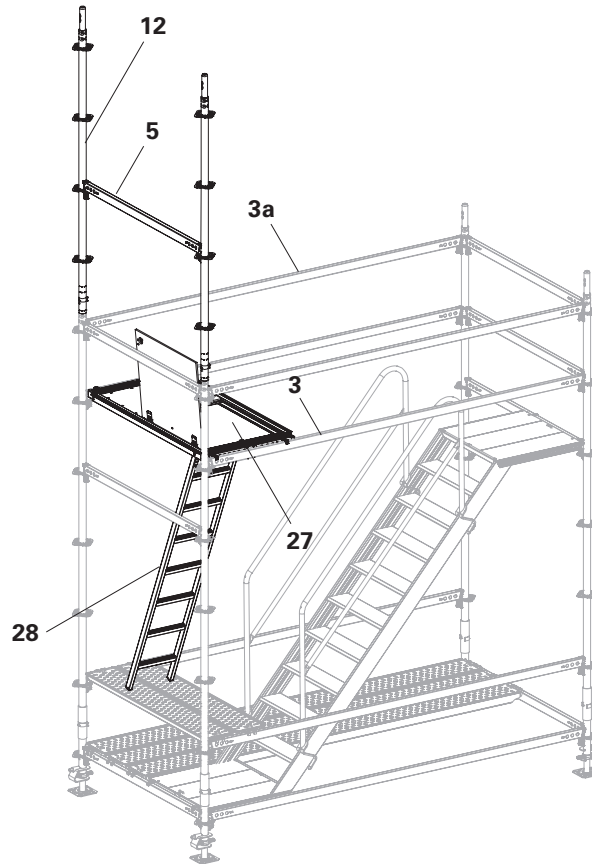

Fig. B4.01

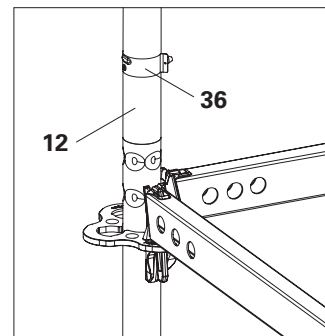

Fig. B4.01a

Flex Stair and guardrail

Components

- 5** Horizontal Ledger UH-2 150
- 12** Standard UVR-2 200
- 15** Flex Stair UAS-2 75 x 300/200
- 17** Stair Guardrail UAG

Assembly

1. Place Flex Stair UAS-2 (**15**) on top and bottom Horizontal Ledgers UH-2 (**5**).
2. Fit 2 x Stair Guardrails UAG (**17 + 17a**) from the position of the landing platform (**17a**).
3. Fit 2 x Standards UVR-2 200 (**12**).
4. Connect standards (**12**) with Horizontal Ledgers UH-2 150 (**5a**) at a height of 2 m. Secure the wedges. (Fig. B4.02)



Internal guardrails (**17a**) are not always required. Observe country-specific regulations.

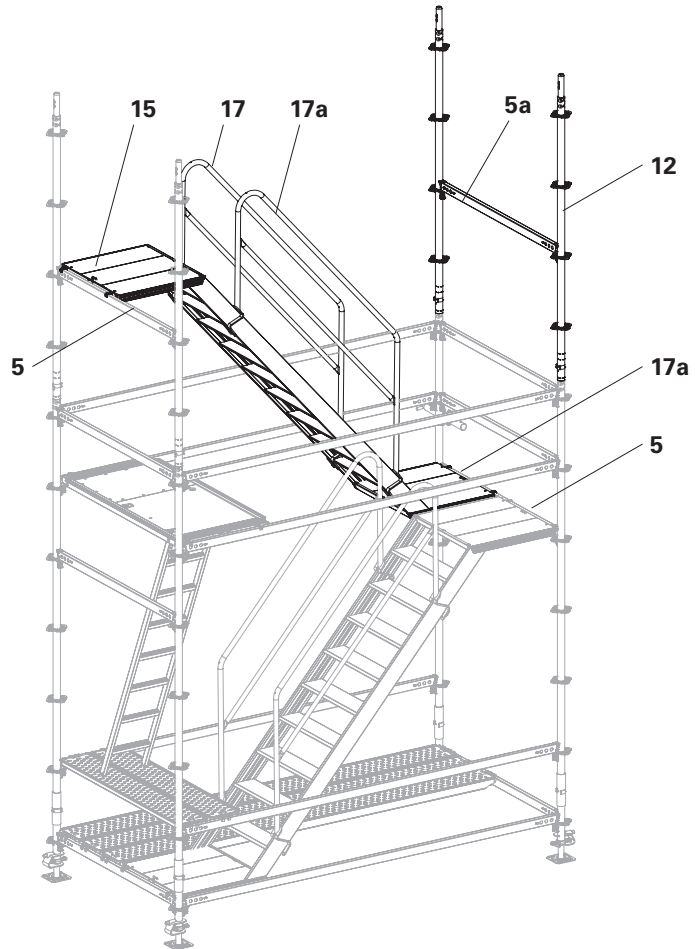

Fig. B4.02

Anchoring



- Ties do not transfer vertical loads!
- Anchorings should be installed progressively with the erection of the scaffolding.
- Fix with eyebolts or equivalent connection.
- The load-bearing capacity of the fixing material between the wall ties and the anchoring base must be verified by the customer for tie load values in Section "B11 Ties, tie forces" on page 74.
- The first tie position should be established at a height of 2.5 m. For the other tie positions, see the tie patterns in the table (Tab. B11.01).
- Each tie position consists of a short tie and a triangulated tie.
- The anchoring can be fitted in a mirror-inverted manner.

Short tie

Components

- 31** Wall Tie UWT 45
- 33** Standard Coupler RA 48/48

Assembly

1. Fix Wall Ties UWT 45 (**31**) to the wall, e.g. with eyebolts and dowels, or equivalent connection.
2. Fasten the Standard Coupler RA 48/48 (**33**) to the inner leg with Wall Tie UWT 45 (**31**). (Fig. B4.03a)

Triangulated tie



The triangulated tie is fitted later, once the passage deck has been removed. See Section "Triangulated tie" on page 55.

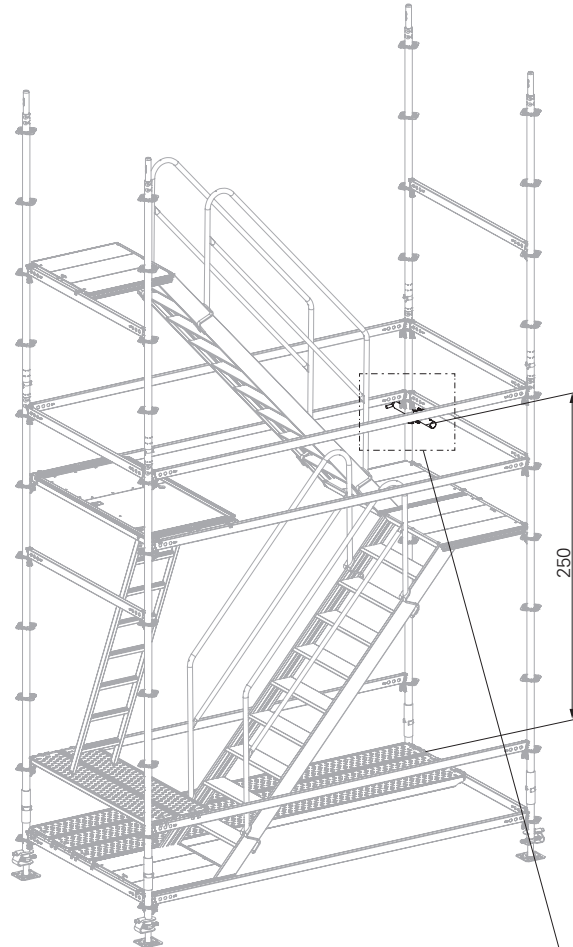

Fig. B4.03

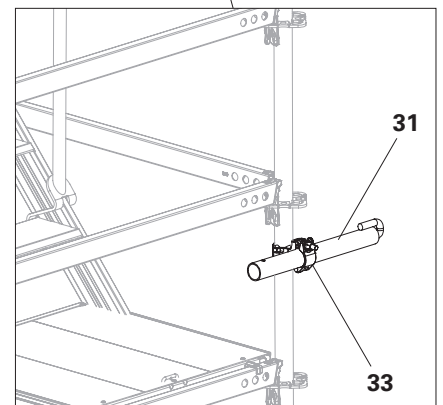

Fig. B4.03a

Passage deck, ledgers and verticals

Components

- 3** Horizontal Ledger UH-2 300
- 5** Horizontal Ledger UH-2 150
- 12** Standard UVR-2 200
- 26** Steel Deck UDG-2 25 x 150
- 27** Passage Deck UAW 75 x 150
- 28** Ladder UAF 200, Alu

1. Place 2 steel decks (**26**) on Horizontal Ledger UH-2 300 (**3**) as an assembly aid.
2. From the position of the Flex Stair (**15**) and steel decks (**26**), fit 3 x Horizontal Ledgers UH-2 300 (**3a**) and 2 x UH-2 150 (**5a**).
3. Fit the Passage Deck UAW 75 x 150 (**27**) onto the next intermediate guardrail level and attach the Ladder UAF 200 (**28**).
4. From the position of the ladder, fit the fourth Horizontal Ledger UH-2 300 (**3b**).
5. Insert Standards UVR-2 (**12**).
6. Fit Horizontal Ledgers UH-2 (**5**) and secure wedges with hammer blow.



If relocation by crane is envisaged, connect all verticals with locking pins D48/ D57 (**35**) so that they are tension-proof.

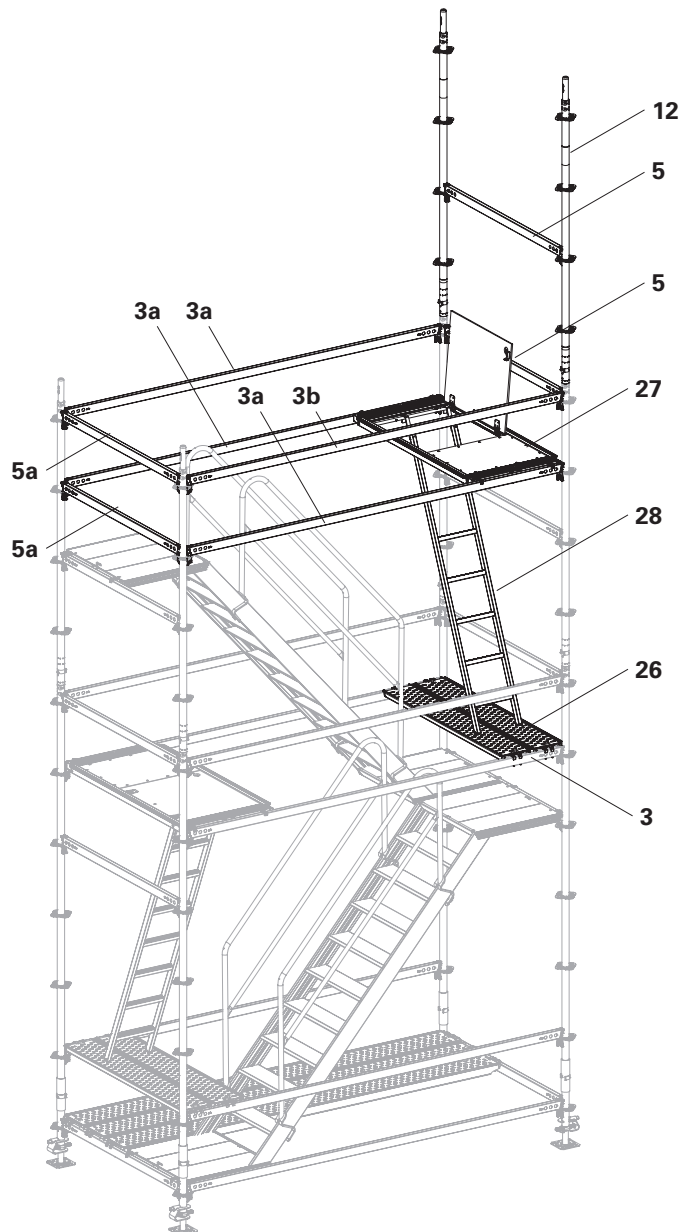

Fig. B4.04

Flex Stair

Components

-
- 15** Flex Stair UAS-2 75 x 300/200
 - 30** Wall Tie UWT 220
 - 33** Standard Coupler RA 48/48
-

Assembly

1. Place Flex Stair UAS-2 (**15**) on top and bottom Horizontal Ledgers UH-2 (**5**). (Fig. B4.05)
2. Remove the passage deck (**27**) and ladder (**28**) and have them ready for the next staircase.



Continue building the next staircase, referring to Section "Auxiliary decks and ledgers" on page 49.

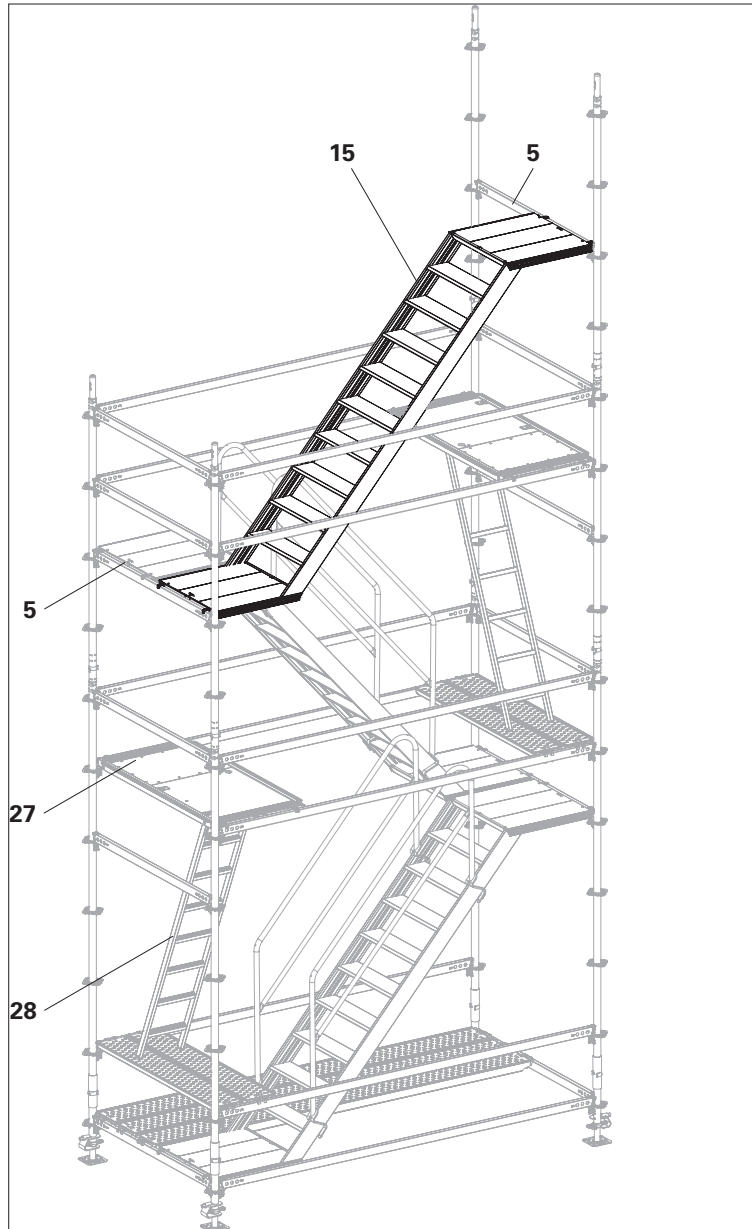

Fig. B4.05

Triangulated tie

Components

- 30** Wall Tie UWT 220
- 33** Standard Coupler RA 48/48

Assembly

1. Fix the first Wall Tie UWT 220 (**30**) to the inner and outer Standards UVR-2 with Standard Couplers NK 48/48 (**33**).
2. Fix the second Wall Tie UWT 220 (**30a**) to the outer Standard UVR-2 with Standard Coupler RA 48/48 (**33**).
3. Fix wall ties to the wall, e.g. with eyebolts and dowels, or equivalent connection.

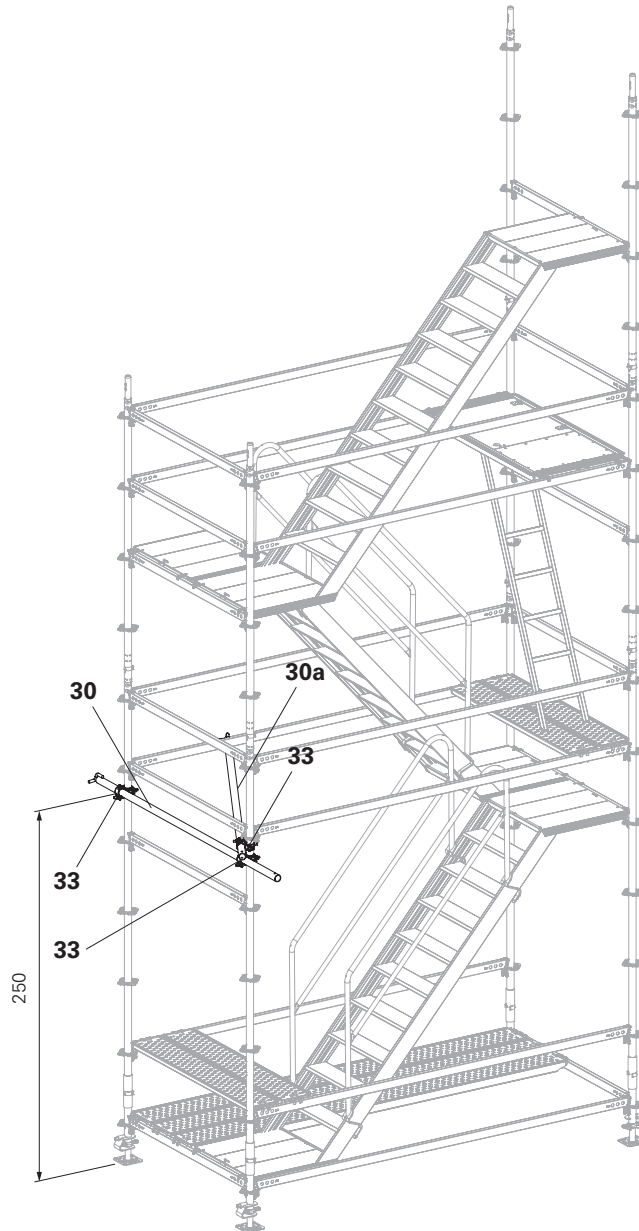

Fig. B4.06

The uppermost level is provided with an additional guardrail as anti-fall protection for accessing the building.

Components

- 3** Horizontal Ledger UH-2 300
- 5** Horizontal Ledger UH-2 150
- 6** Horizontal Ledger UH-2 75
- 12** Standard UVR-2 200
- 15** Flex Stair UAS-2 75 x 300/200
- 17** Stair Guardrail UAG
- 19** Steel Deck UDG-2 25 x 300
- 24** Ledger-to-Ledger Coupler UHA-2
- 25** UH Spigot-2

Assembly

1. As with the installation of an additional level, fit Standards UVR-2 (**12**) and connect them with horizontal ledgers (**5**).
2. Flex Stair UAS-2 (**15**).
3. Fit a Stair Guardrail UAG (**17**) on the outside of the stair. (Fig. B5.01)
4. Fit one Ledger-to-Ledger Coupler UHA-2 (**24**) in the centre of each of the two Horizontal Ledgers UH-2 150.
5. Fit a Horizontal Ledger UH-2 300 (**3**) onto the ledger-to-ledge couplers.
6. Fit a UH-Spigot-2 (**25**) onto the horizontal ledger at a distance of 1 m.
7. Fit Steel Decks UDG-2 25 x 300 (**19**) onto the uppermost level. (Fig. B5.02)

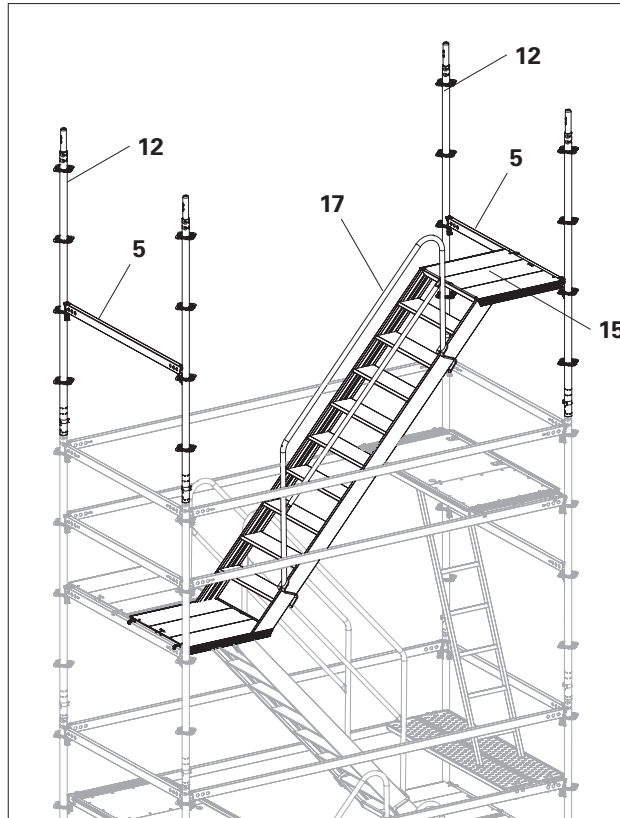

Fig. B5.01

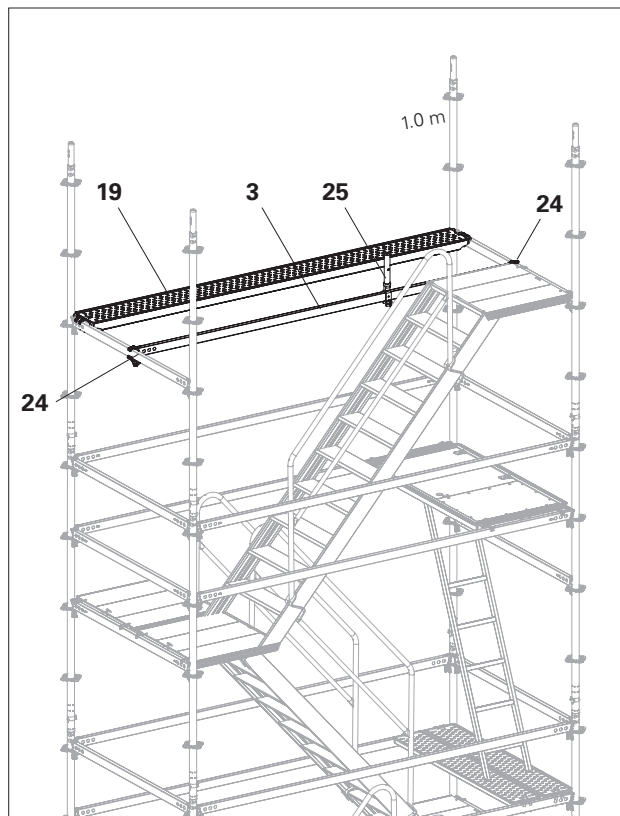

Fig. B5.02

Components

- 10** Standard UVR-2 100
- 17** Stair Guardrail UAG
- 30** Wall Tie UWT 220
- 31** Wall Tie UWT 45
- 33** Standard Coupler RA 48/48

1. Fit a Standard UVR-2 100 (**10**) or Top Standard UVH 100 onto the UH-Spigot-2.
2. Fit a Stair Guardrail UAG (**17a**) onto the inside of the stair. (Fig. B5.03)

Fitting triangulated ties

1. Fix the first Wall Tie UWT 220 (**30**) to the inner and outer Standards UVR-2 with Standard Couplers NK 48/48 (**33**).
2. Fix the second Wall Tie UWT 220 (**30a**) to the outer Standard UVR-2 with Standard Coupler RA 48/48 (**33**).
3. Fix wall ties to the wall, e.g. with eyebolts and dowels, or equivalent connection. (Fig. B5.03)

Fitting the short tie

1. Fix Wall Ties UWT 45 (**31**) to the wall, e.g. with eyebolts and dowels, or equivalent connection.
2. Fasten the Standard Coupler RA 48/48 (**33**) to the inner leg with Wall Tie UWT 45 (**31**). (Fig. B5.04)



Fit the tie on the outside if possible. This reduces interference points in the traffic area.



Internal guardrails (**17a**) are not always required. Observe country-specific regulations.

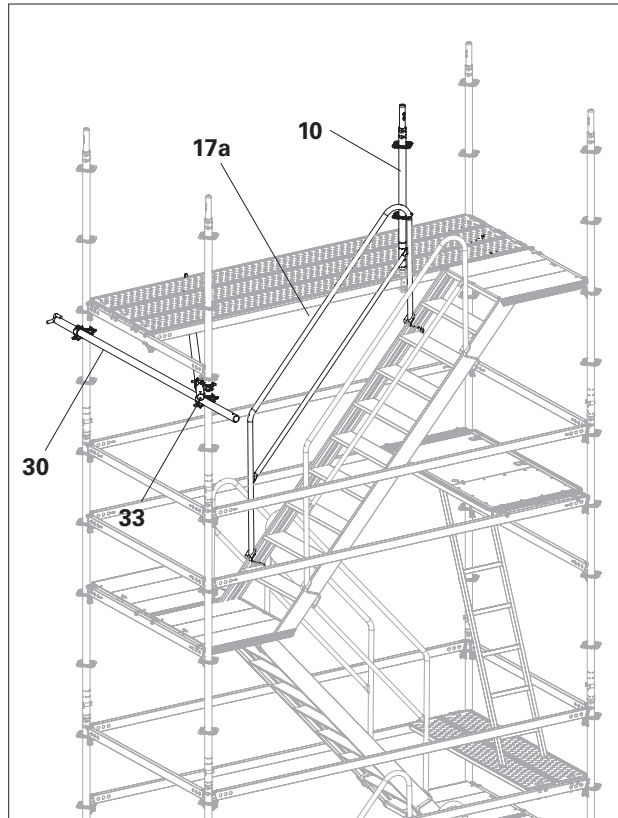

Fig. B5.03

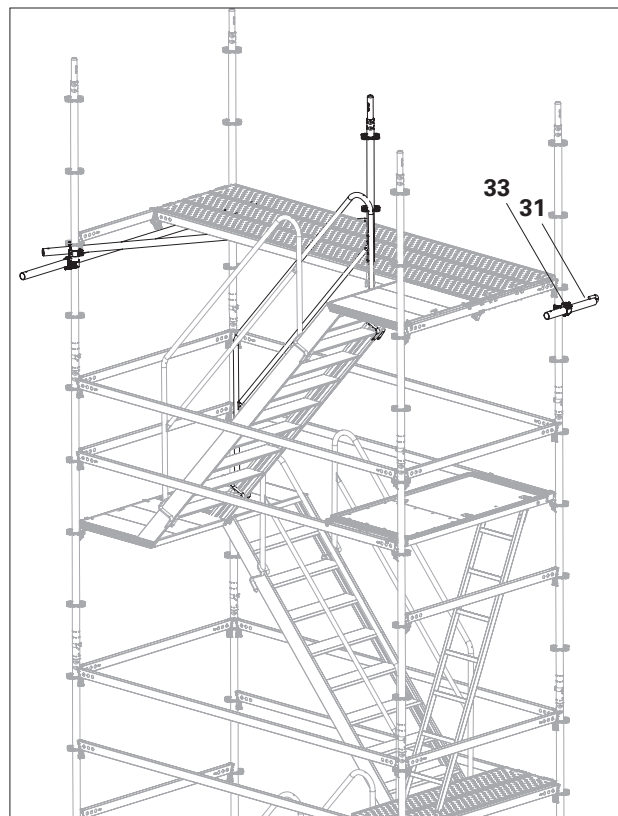

Fig. B5.04

Components

- | | |
|-----------|--------------------------------|
| 3 | Horizontal Ledger UH-2 300 |
| 4 | Horizontal Ledger UH-2 200 |
| 5 | Horizontal Ledger UH-2 150 |
| 6 | Horizontal Ledger UH-2 75 |
| 8 | Horizontal Ledger UH-2 25 |
| 10 | Standard UVR-2 100 |
| 24 | Ledger-to-Ledger Coupler UHA-2 |

Installing the lateral protection

1. Fit Horizontal Ledgers UH-2 300 (**3**) and UH-2 150 (**5 + 5a**).
 2. Fit 2 x Ledger-to-Ledger Couplers UHA-2 (**24**) in the centre of each of the 2 Horizontal Ledgers UH-2 150 (**5a**).
 3. Fit 2 x Horizontal Ledgers UH-2 200 (**4**) onto the ledger-to-ledger couplers and standard.
 4. For bracing, fit a Horizontal Ledger UH-2 75 (**6**) between the horizontal ledgers (**3 + 4**) using ledger-to-ledger couplers (**24a**). (Fig. B5.05)
- The uppermost level is installed.

For exit width 75 cm:

5. Pre-assemble two Horizontal Ledgers UH-2 25 (**8**) on a Standard UVR-2 100 (**10a**).
6. Hook the assembly (**8 + 10a**) with the horizontal ledgers (**8**) into the standard (**10**). Secure the wedges. (Fig. B5.06)



Leave the horizontal ledger (**3b**) in place until a safe transition can be guaranteed.

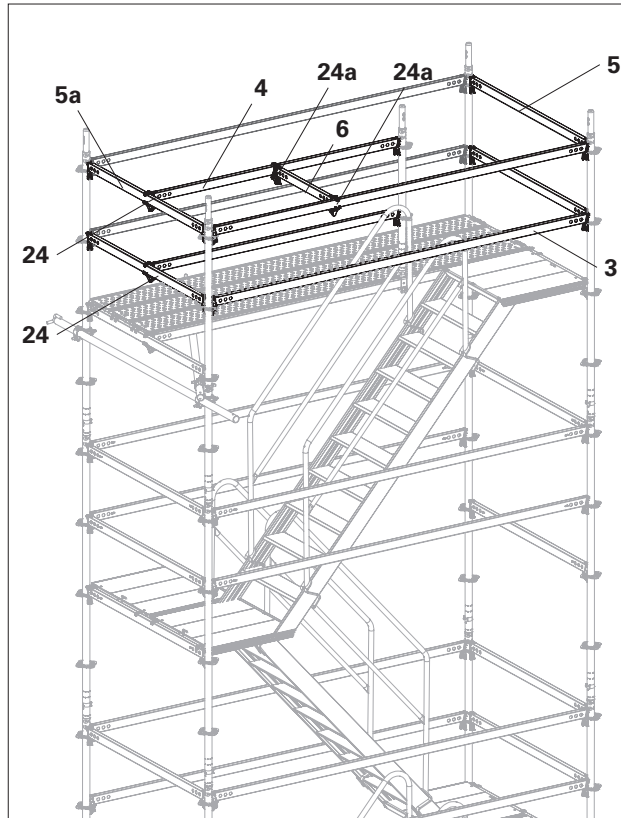

Fig. B5.05

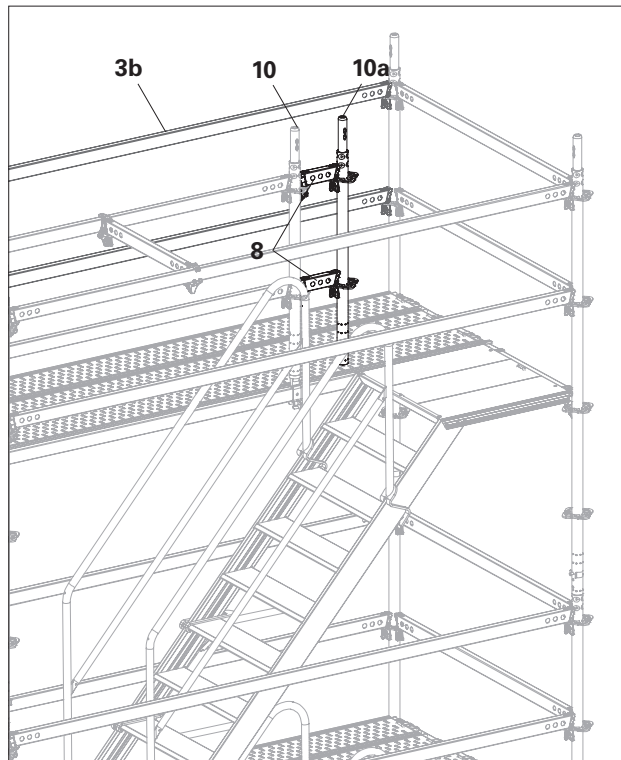

Fig. B5.06

Height adjustment through exit point via front-side console brackets



- Max. height of the stair tower: 30 m.
- Permissible load on the console bracket: 2 kN/m².
- Exit point via front-side console brackets. Height adjustment possible with 4 versions:
 - UAS-2 75 x 150/100 S +1.0 m
 - UAS-2 75 x 150/100 T -1.0 m
 - UAS-2 75 x 150/50 S +0.5 m
 - UAS-2 75 x 150/50 T -0.5 m
- Tie spacing: 8 m.
- Depicted: Flex Stair with +1.0 m.
- Below the exit point, ledger braces must be fitted directly underneath each anchoring position. See Section "Bracing" on page 63.
- No ledger braces are required underneath the first anchoring point.
- An anchoring point must always be available above a front-side exit point and ledger braces must be fitted.
- $L_{sp} \leq 35$ cm.

Exit point in the tie area

If an exit point encroaches into the tie area:

- Move the tie position 4 m downwards.
- In addition, fit another anchoring position 2 m upwards in a mirror-inverted manner.

Exit point not in the tie area

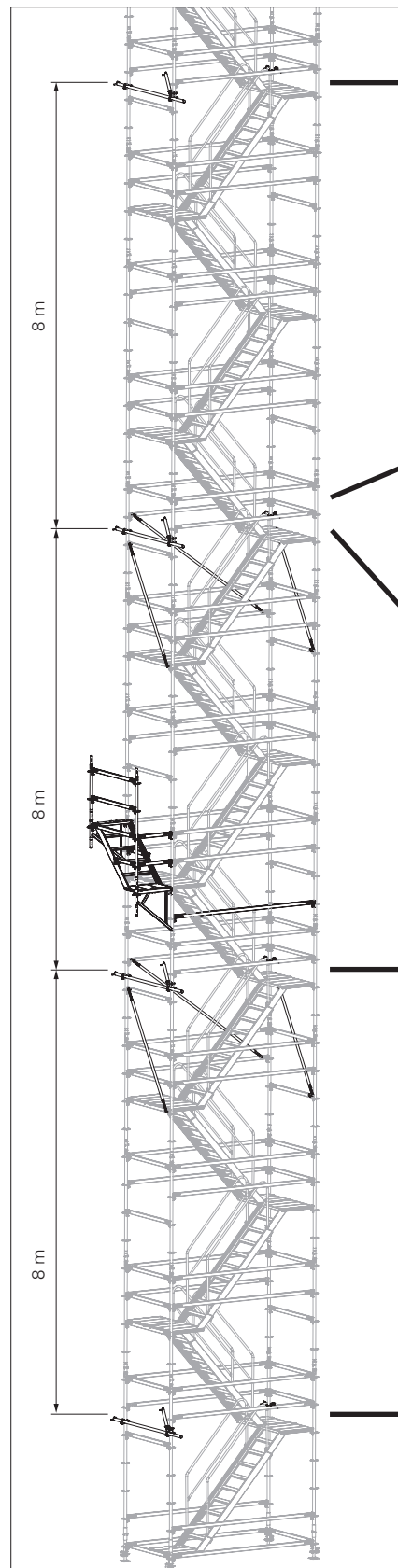

Fig. B6.01

Exit point in the tie area

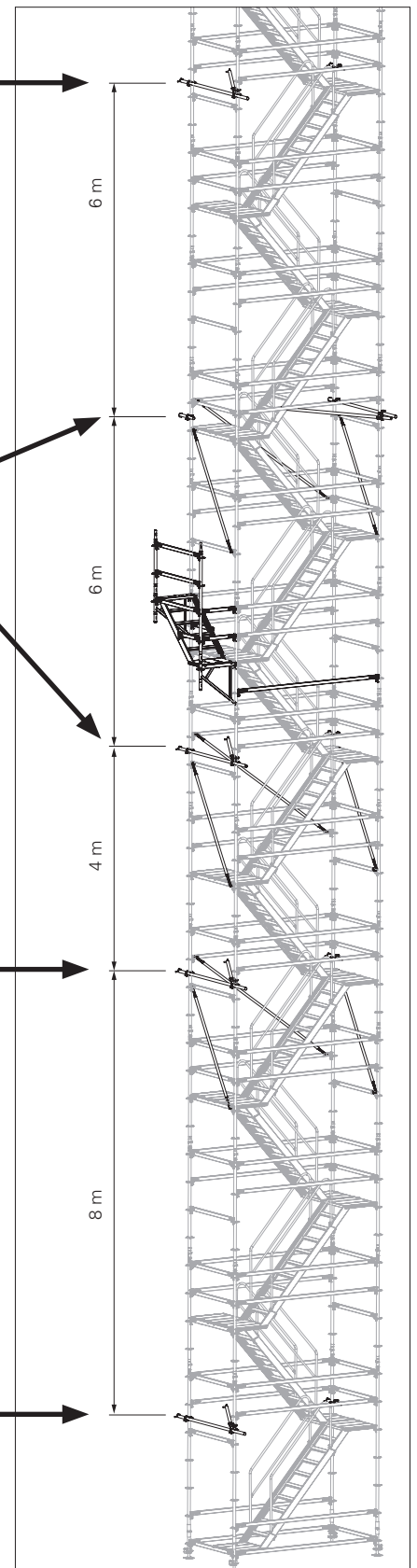

Fig. B6.02

Components

- 3 Horizontal Ledger UH-2 300
- 5 Horizontal Ledger UH-2 150
- 6 Horizontal Ledger UH-2 75
- 10 Standard UVR-2 100
- 11 Standard UVR-2 150
- 12 Standard UVR-2 200
- 16 Flex Stair UAS 75 x 150/100 S
- 37 Flex Stair UAS 75 x 150/50 T
- 20 Console Bracket ECM 75
- 25 UH Spigot-2



Leave the lateral protection (5) in place until after the front-side exit point has been fully assembled.

Exit point with height adjustment +100 cm:

Assembly

From a secured position:

1. Fit Console Brackets ECM (20) – 2 x.
2. Fit Standards UVR-2 (12 + 10).
3. Add Horizontal Ledger UH-2 300(3) 50 cm beneath the suspension of the console bracket, if not available. (Fig. B6.03)
4. Attach the flex stair (16). (Fig. B6.04)

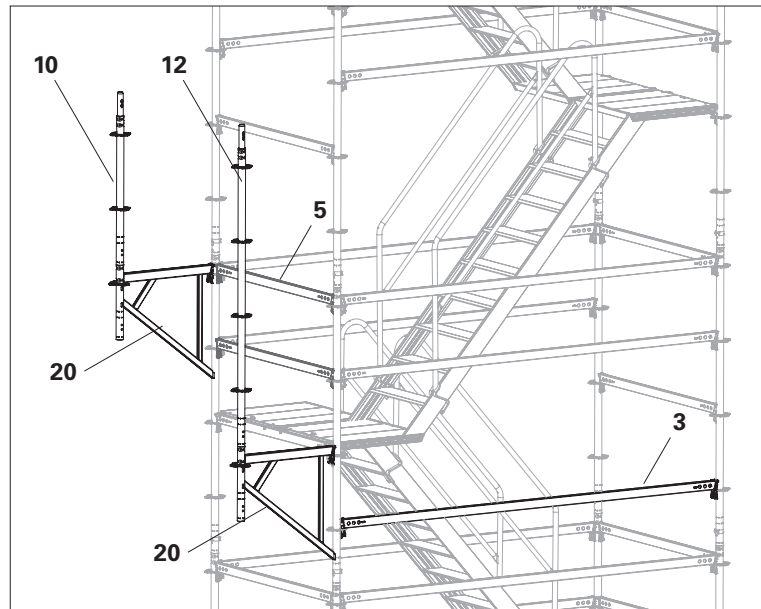

Fig. B6.03

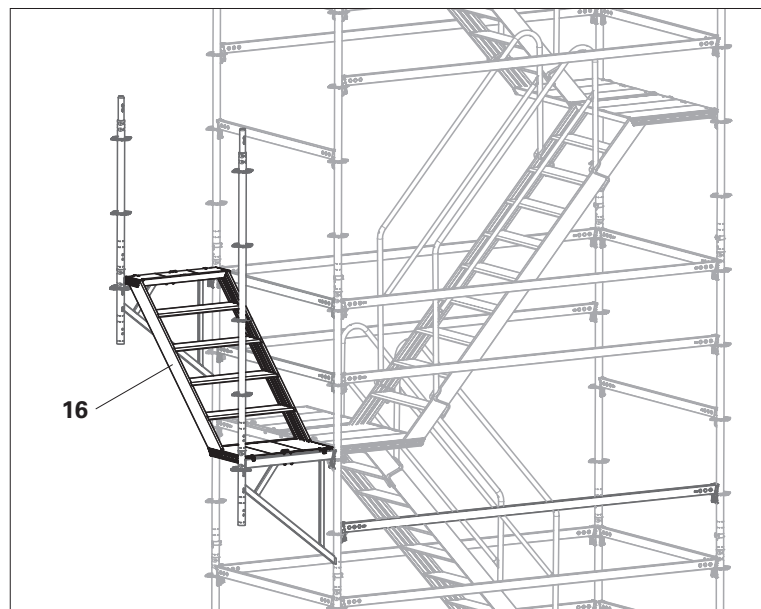

Fig. B6.04

5. Fit Horizontal Ledger UH-2 150 (**5**)
1x + UH-2 75 (**6**) 4x as lateral protection.
6. Remove Horizontal Ledger UH-2 150 from the base scaffold and fit it at the exit point as lateral protection (**5a**). (Fig. B6.05)

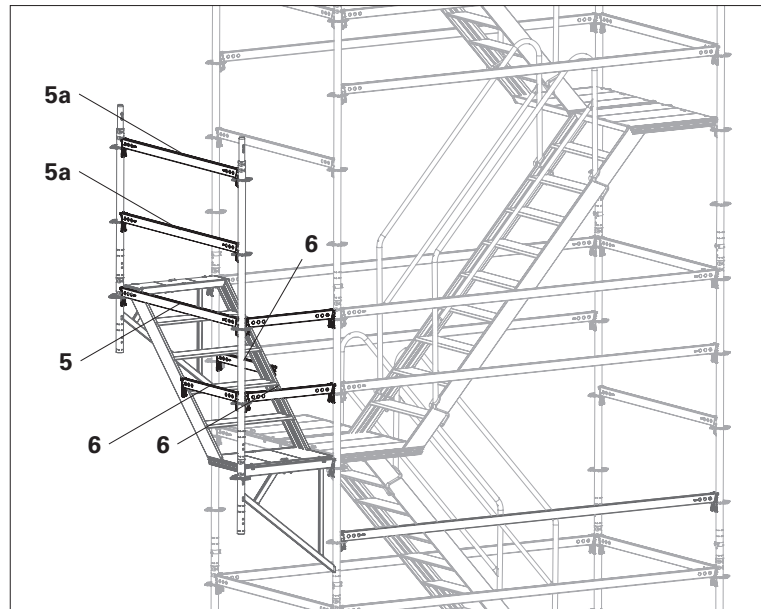

Fig. B6.05

Exit point with height adjustment -50 cm:

Assembly:

In addition to previous section, fit the following:

1. Fit a UH-Spigot-2 (**25**) onto the horizontal ledger.
2. Fit a Standard UVR-2 100 (**10**).
3. Fit 2 x Horizontal Ledgers UH-2 75 (**6**) as lateral protection. (Fig. B6.06)
4. Instead of a Standard UVR-2 200 UVR-2, fit a Standard 150 (**11**).

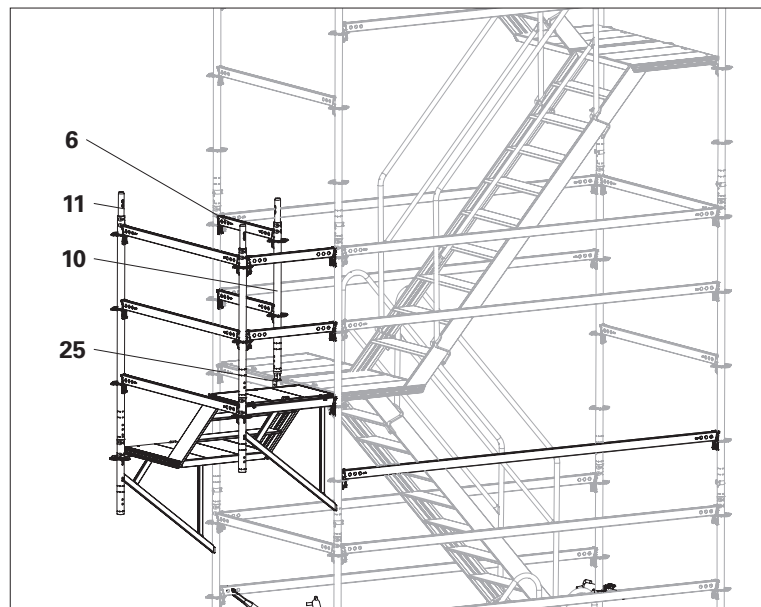

Fig. B6.06

Mirror image of structure

The mirror-image structure is permissible and built analogously.

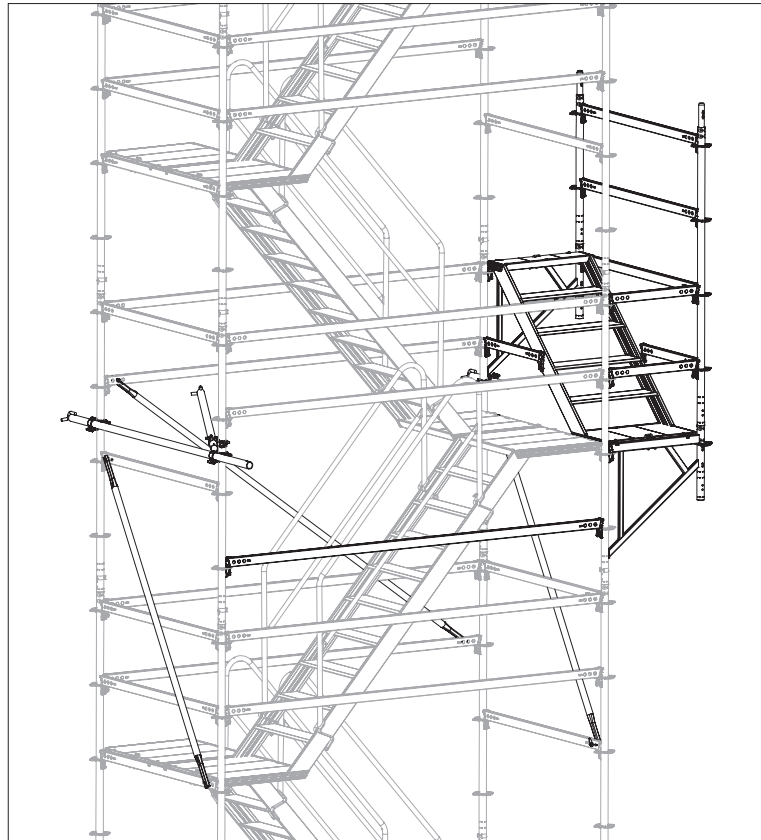

Fig. B6.07

Bracing

Exit point not in the tie area

Components

- 21** Ledger Brace UBL-2 150/200
- 23** Ledger Brace UBL-2 300/200

Assembly

1. Directly below the next highest anchoring point:
fit 2 x ledger braces (**21**) and
1 x ledger brace (**23**).
2. Directly below each anchoring point
positioned below:
fit 2 x ledger braces (**21a**) and
1 x ledger brace (**23a**) on the inner
side. (Fig. B6.08)
→ No ledger braces are required un-
derneath the first anchoring point.

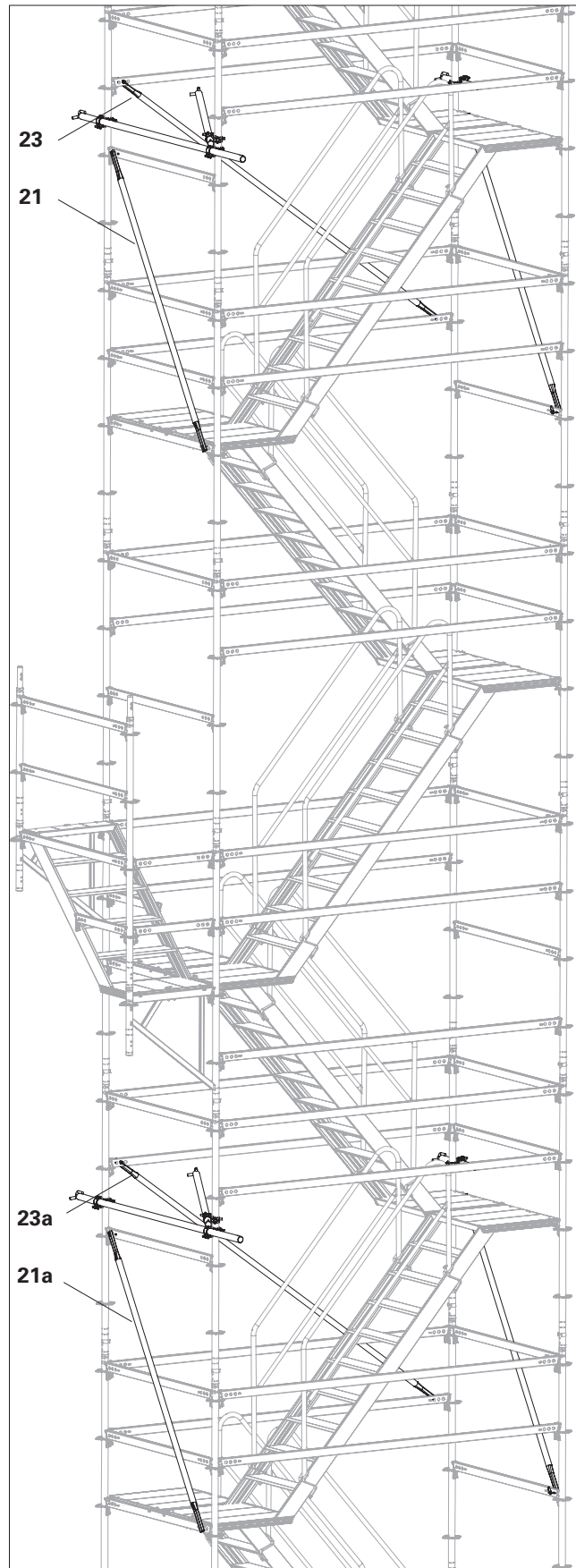

Fig. B6.08

Bracing

Exit point in the tie area

Components

3	Horizontal Ledger UH-2 300
5	Horizontal Ledger UH-2 150
21	Ledger Brace UBL-2 150/200
23	Ledger Brace UBL-2 300/200

Moving the anchoring

When an exit point is required in an anchored position:
 Move the intended anchoring 4 m downwards and fit another anchoring position 4 m above it.

Example:

Exit point at height of 10 m, tower 28 m:

→ Tie positions before:
 2.5 m, 10.5 m, 18.5 m, 26.5 m.

→ Tie positions after:
 2.5 m, 6.5 m, 12.5 m, 18.5 m, 26.5 m.

Brace the tie positions at 6.5 m and 12.5 m without ledger braces.

Assembly

1. Add Horizontal Ledgers UH-2 300 (**3**) and Horizontal Ledgers UH-2 150 (**5**) as required.
2. Directly below the next highest anchoring point:
 fit 2 x ledger braces (**21**) and 1 x ledger brace (**23**).
3. Directly below all anchoring points positioned below:
 fit 2 x ledger braces (**21a**) and 1 x ledger brace (**23a**) on the inner side. (Fig. B6.09)
 → No ledger braces are required underneath the first anchoring point.

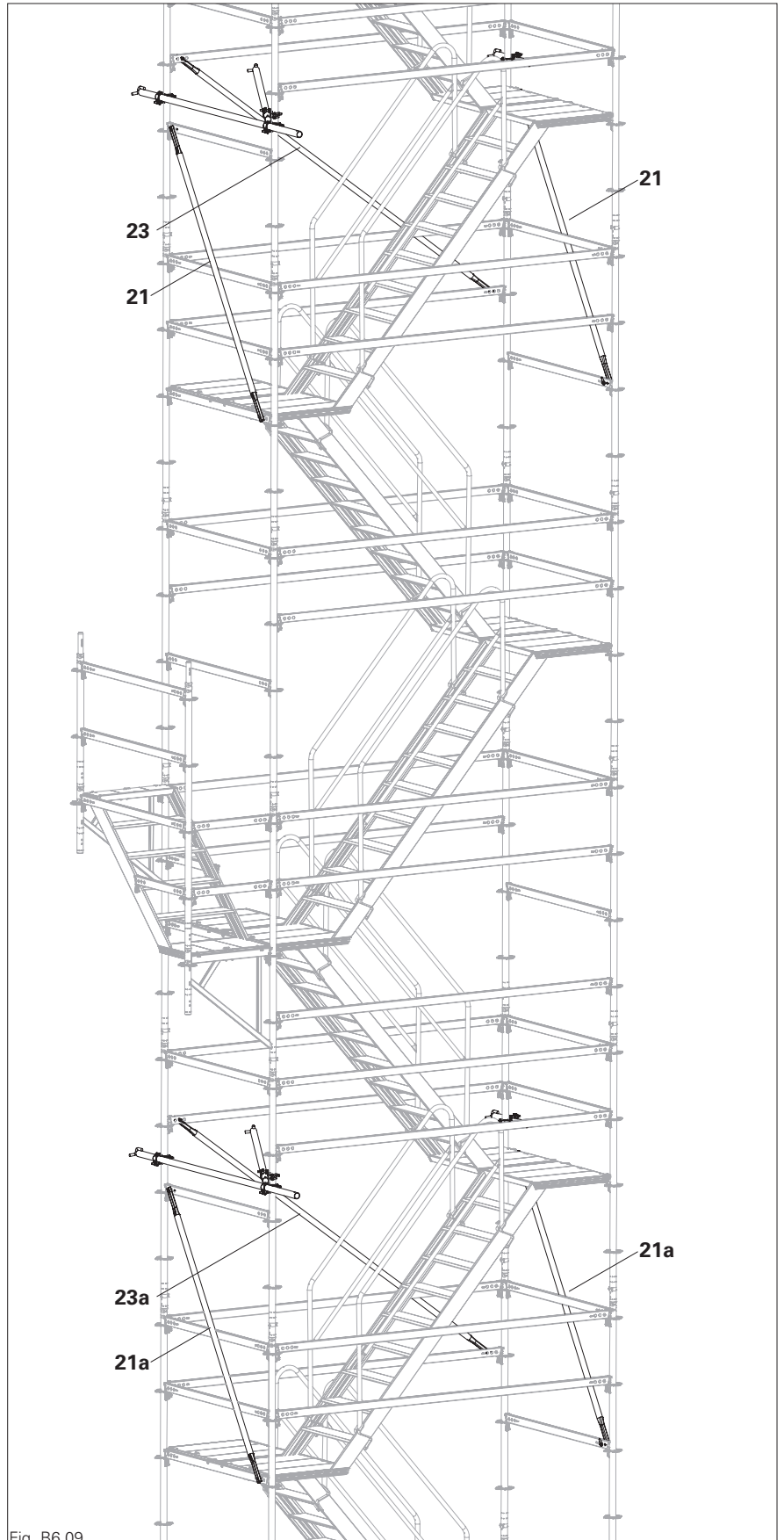

Fig. B6.09

Shaft staircase

Deviating components

- 4 Horizontal Ledger UH-2 200
- 5 Horizontal Ledger UH-2 150
- 16 Flex Staircase UAS-2 75 x 150/100
- 26 Steel Deck UDG-2 25 x 150
- 31 Wall Tie UWT 45
- 33 Standard Coupler RA 48/48



- Variant shown: 150 x 200 cm.
- Distance between landing platform levels ≤ 100 cm.
- Max. height of the stair tower: 30 m.
- Permissible load: 2 kN/m².
- Horizontal equivalent load 0.3 kN per loadable scaffolding level. Wind loads in the shaft excluded.
- Distance between intermediate access points min. 2 m.
- Exit levels must be closed all around at landing platform height using horizontal ledgers.
- Support the exit level at landing platform height and the landing platform level 2 m above in a pressure-resistant manner all the way around.
- From the rules mentioned above, the following possibilities arise:
 - Exit point at 3, 5, 7, 9 m
 - Exit point at 2, 4, 6, 8 m
 - Exit point at 3, 6, 9, 12 m
- Bracing grid:
 - ≤ 6 m,
 - Always brace the uppermost level.
- Plan vertical joints in such a way that they can always be closed with horizontal ledgers all the way round.

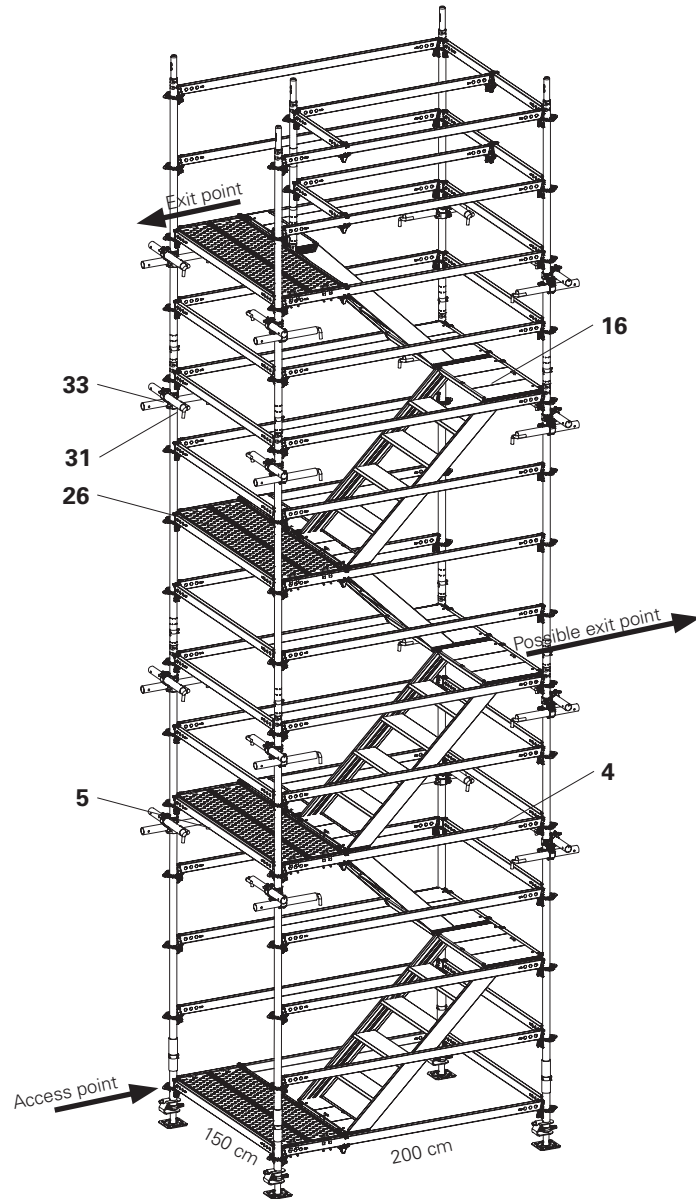

Fig. B6.10

Ensure use of internal Guard
 Rails between flights:
 Use 1m UAH

Pressure-resistant support

Components

- 1** Base Spindle UJB
- 31** Wall Tie UWT 45
- 32** Scaffolding Tube 48.3 x 3.2 mm
- 33** Standard Coupler RA 48/48

Variant 1

1. Insert the base spindle (**1**) into the scaffolding tube (**32**).
2. Butt the scaffolding tube against a wall and bolt it to standards with standard coupler (**33**).
3. Spindle the base spindle up against the other wall. (Fig. B6.11)

Variant 2

For each vertical, securely attach 2 short Wall Ties UWT (**31**) to the scaffold using a standard coupler (**33**) over the corner. Position the end without a hook so it butts against the wall. (Fig. B6.12)

Variant 1

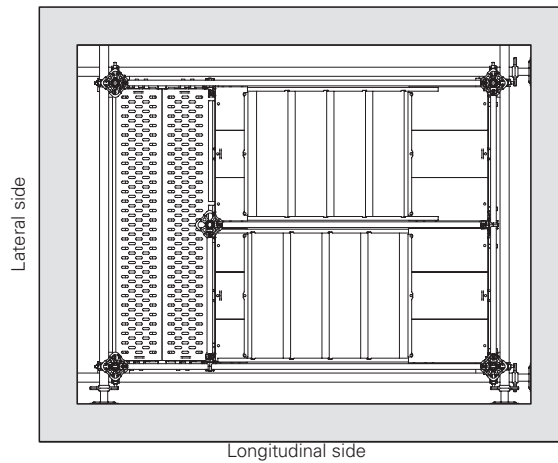
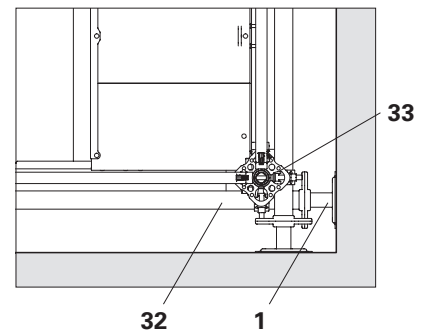

Fig. B6.11



Variant 2

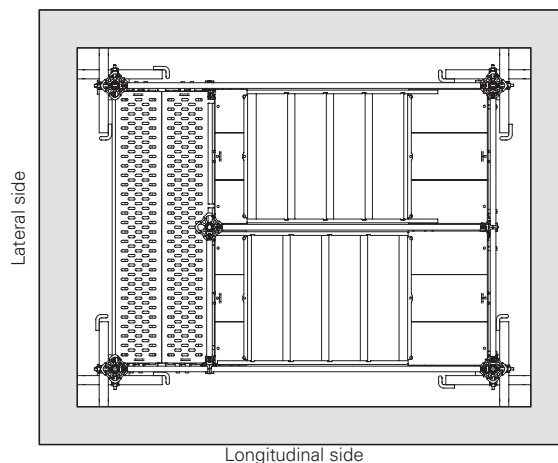
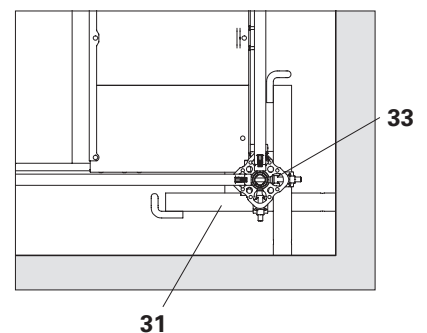

Fig. B6.12



Uneven heights

If possible, make height adjustments at the base of the stairs.

Components

3	Horizontal Ledger UH-2 300
5	Horizontal Ledger UH-2 150
6	Horizontal Ledger UH-2 75
12	Standard UVR-2 200
16	Flex Stair UAS-2 75 x 150/100
19	Steel Deck UDG-2 25 x 300
26	Steel Deck UDG-2 25 x 150
24	Ledger-to-Ledger Coupler UHA-2
30	Wall Tie UWT 220
31	Wall Tie UWT 45

Assembly

1. Fit the base frame, see Section "B3 Base level" on page 46.
2. Insert Standards UVR-2 (**12**). The length of the verticals depends on the Flex Stair used. (Flex Stair height + 1 m)
3. Fit additional Horizontal Ledgers UH-2 300 and 150 (**3 + 5**) as lateral protection.
4. Fit Ledger-to-Ledger Couplers UHA-2 in the centre of the bay (**24**).
5. Fit additional Horizontal Ledgers UH-2 300 (**3a**).
6. Fit Ledger-to-Ledger Couplers (**24a**) and Horizontal Ledgers UH-2 75 (**6**) as a lower stair support.
7. Fit Flex Stair UAS-2 75 x 150/100 (**16**).
8. Fit steel deck (**19 + 26**) – 3 x in each case.
9. Fit the anchoring (**30 + 31**), see Section "Anchoring" on page 52.



- Reaction force
 - see Section A9.1.
 - use the next highest access height.
- Ties and tie forces
 - see Section A10.
 - Move tie installation height downwards by 1 m.

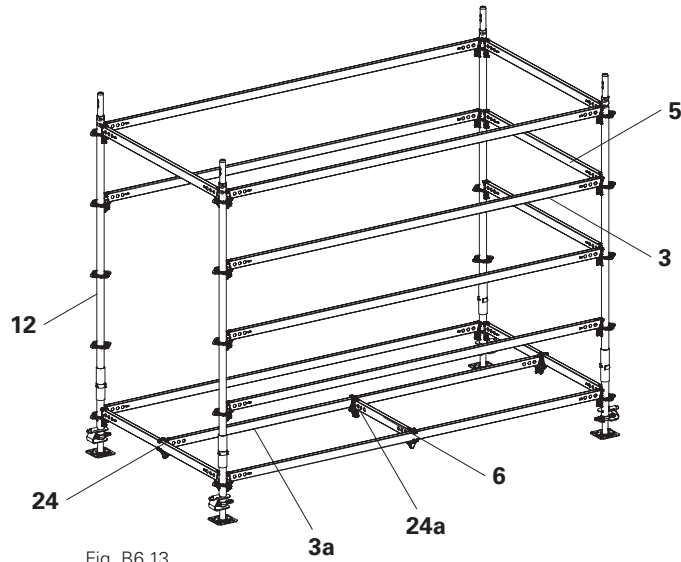

Fig. B6.13

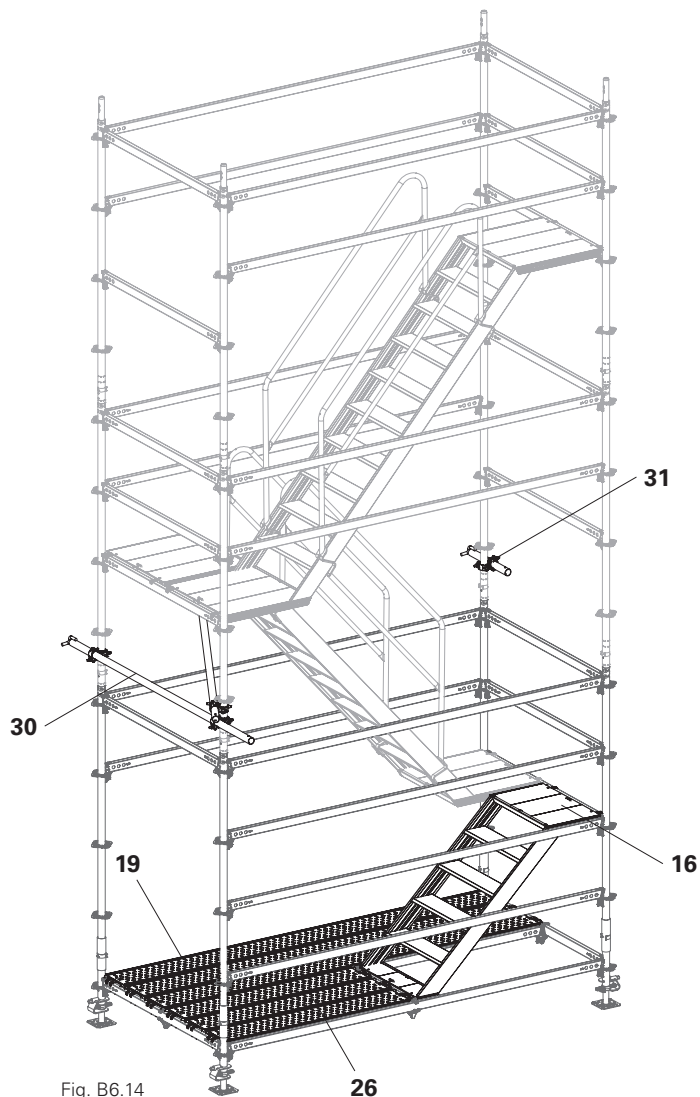

Fig. B6.14

Extended lateral protection

Depending on national regulations, further horizontal ledgers may be required as lateral protection.

Components

- 3 Horizontal Ledger UH-2 300
- 5 Horizontal Ledger UH-2 150

Assembly

Install additional horizontal ledgers progressively with the assembly of the stair tower.

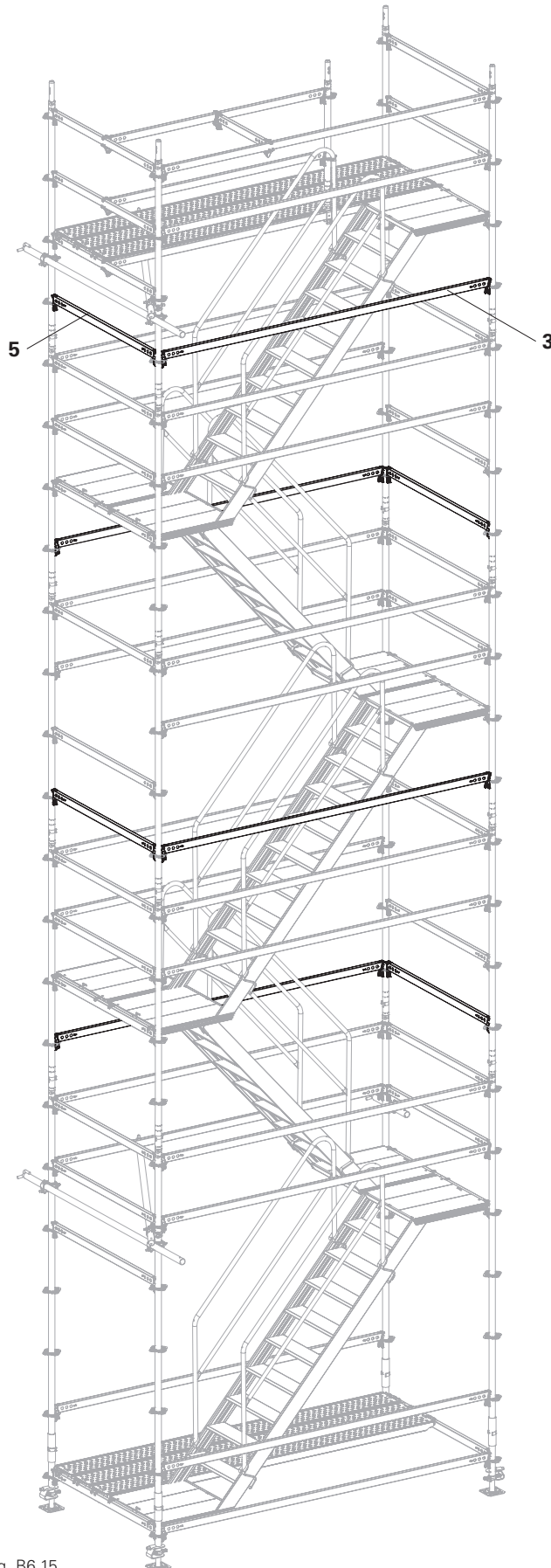

Fig. B6.15

Lateral intermediate access points

Intermediate access points can be installed on every 2nd staircase.

Components

- 3** Horizontal Ledger UH-2 300
- 22** Ledger Brace UBL-2 300/200
alternatively:
- 32** Scaffolding tubes 48.3 x 3.2 mm
- 34** Swivel couplings AF 48/48

Measures on the wall side

- Move both Horizontal Ledgers UH-2 300 (**3**) up and down.
- Fit additional horizontal ledgers (**3a**) onto the floors above and below.
- Fit Ledger Braces UBL-2 (**22**) onto the floors above and below. (Fig. B7.01 + Fig. B7.02)
- Fit additional ties, see Section "Tie positions – installation heights" on page 74.

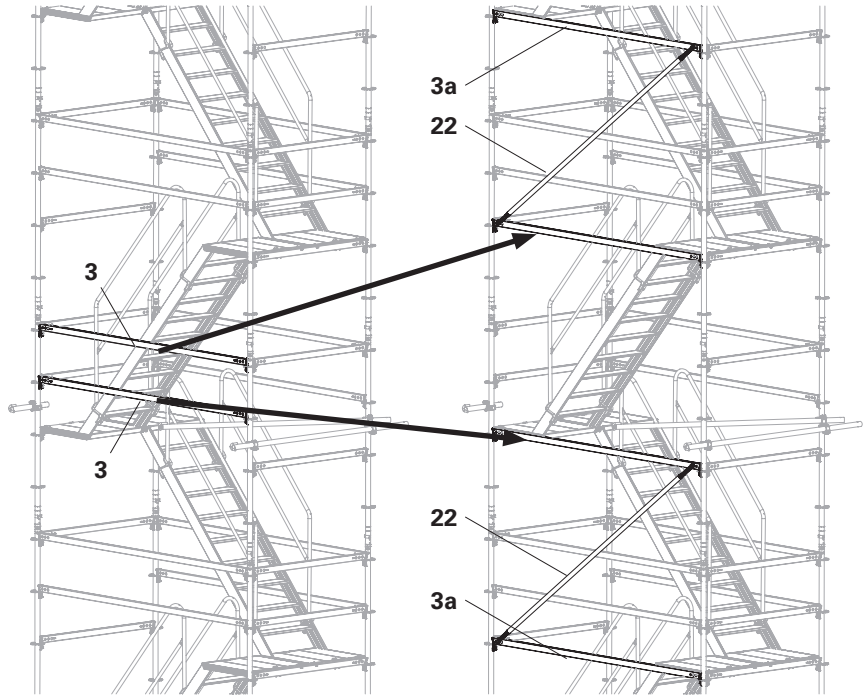

Fig. B7.01

Fig. B7.02

Heights of 52 m and above

- Fit Ledger Braces UBL-2 in the lower levels in accordance with Section "Tie positions – installation heights" on page 74. (Fig. B7.04)
- If exit points are required at the lower levels, then exit via the front sides.

View of wall side

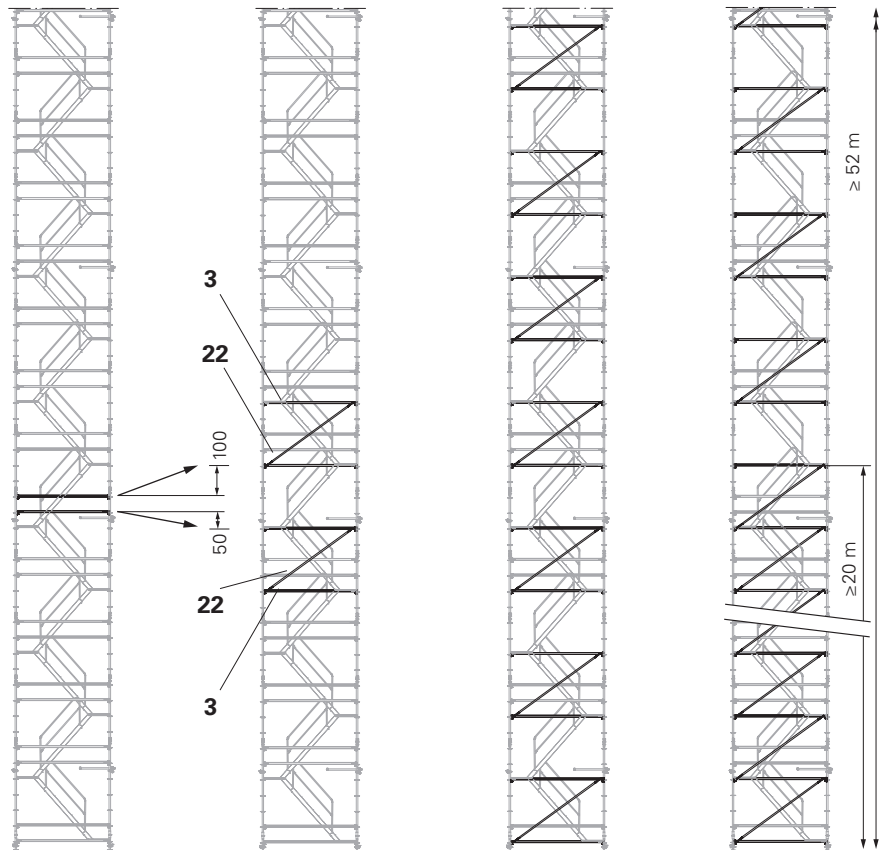

Fig. B7.03

Fig. B7.03a

Fig. B7.03b

Fig. B7.04

Refer to Instructions for Short Lift systems to NASC SG4:15



Warning

Throughout the entire disassembly process, there is a risk of falling due to the partial lack of lateral protection.

A fall can result in serious injuries or even death.

⇒ Use PPE to prevent falls.

Additionally required components

26 Steel Deck UDG-2 25 x 150

27 Passage Deck UAW 75 x 150

28 Ladder UAF 200, Alu

Disassembly

- Dismantle from top to bottom, i.e. in the reverse order as shown in the assembly procedure.
- Remove the anchorings progressively along with the Flex Stair from top to bottom.
- In the event of work being interrupted, the top level should not extend more than 2.0 m beyond the last tie position.
- Passage decks and steel decks move down 2 flights of stairs at a time, in an alternating manner.



The scaffolding contractor may opt for a different disassembly sequence. A risk assessment is always required.

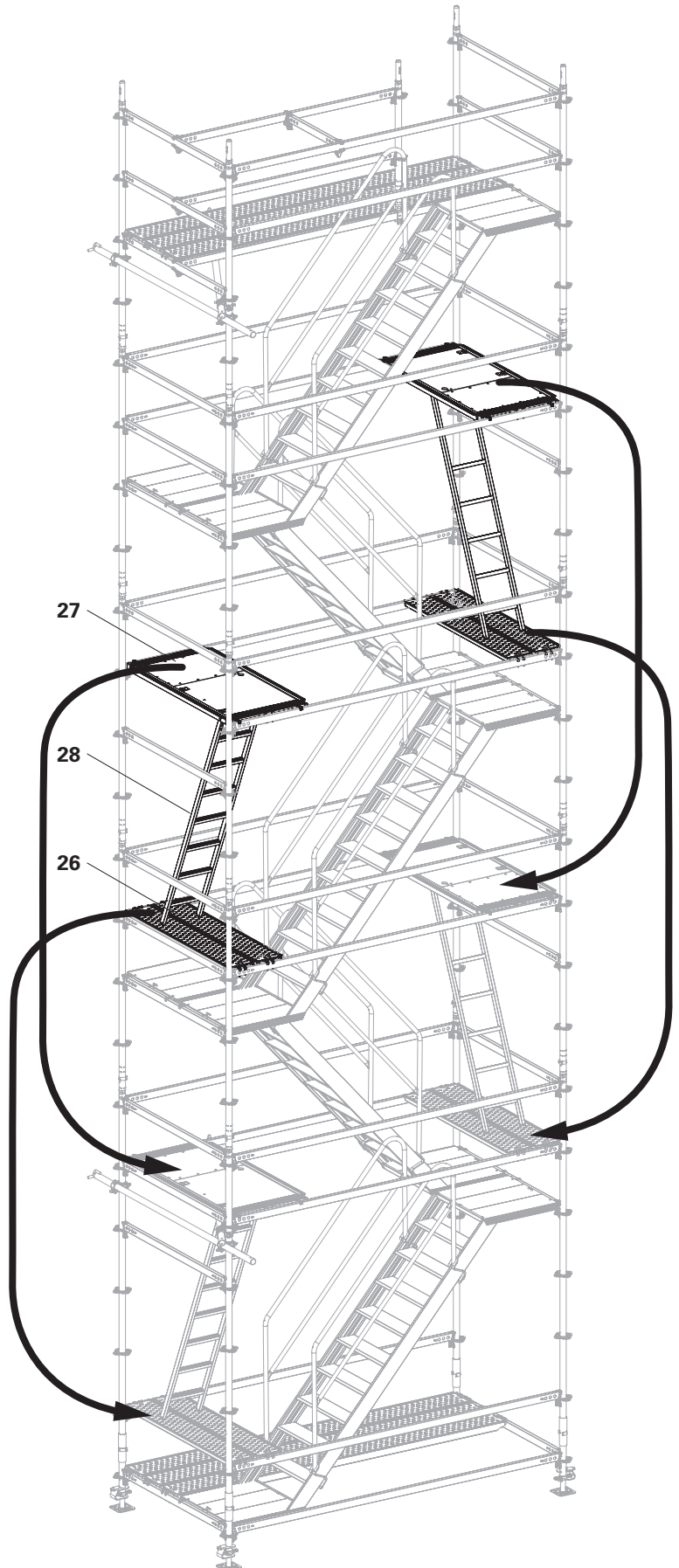
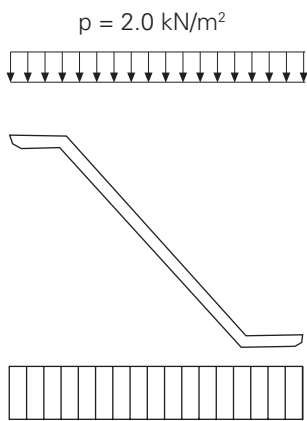

Fig. B8.01

Flex Stair UAS-2

The permitted load for the flights of stairs is $p = 2.0 \text{ kN/m}^2$ (on landings platforms and steps).

Flight of stairs UAS 75x250/200
or UAS 75x300/200



Loads on stair tower

A stair tower consists of several flights of stairs, which are arranged above one another like a tower.

The permissible load of the stair tower is $p = 2.0 \text{ kN/m}^2$ for a maximum length of 20 linear metres.

For stairs with a bay length of 3.0 m, approx. 6 levels are loaded (corresponds to a height of 12 m); for a bay length of 2.50 m, approx. 8 levels (corresponds to a height of 16 m).

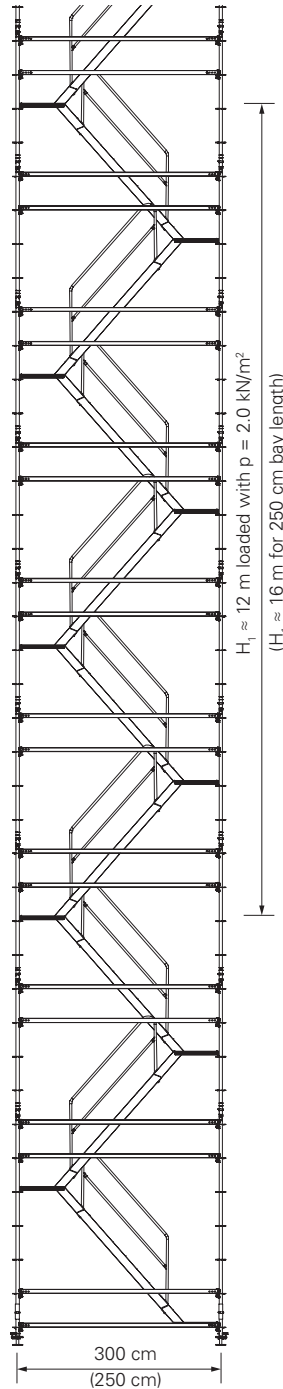

Fig. B9.01

Reaction forces

The reaction forces for the stair towers are given in the table and depend on the overall height and bay length respectively. (Tab. B10.01)

For the medium vertical loads, the permissible load was distributed evenly across all verticals. To determine the maximum leg loads, 75% of the permissible load was concentrated on one side of the scaffolding.

Tower height	Foundation for complete tower		Foundation for individual verticals		Flex Stair with alternating staircase units
	medium vertical loads		max. vertical loads		
	Bay lengths				
[m]	250 cm [kN]	300 cm [kN]	250 cm [kN]	300 cm [kN]	
2.3	2.4	2.8	3.2	3.8	
4.3	3.6	4.2	4.8	5.7	
6.3	4.8	5.5	6.4	7.5	
8.3	6.0	6.9	8.0	9.4	
10.3	7.1	8.3	9.6	11.3	
12.3	8.3	9.3	11.2	12.7	
14.3	9.5	9.7	12.8	13.1	
16.3	9.9	10.1	13.2	13.4	
18.3	10.2	10.5	13.6	13.8	
20.3	10.6	10.9	13.9	14.2	
22.3	11.0	11.3	14.3	14.6	
24.3	11.3	11.6	14.6	15.0	
26.3	11.7	12.0	15.0	15.3	
28.3	12.0	12.4	15.4	15.7	
30.3	12.4	12.8	15.7	16.1	
32.3	12.7	13.2	16.1	16.5	
34.3	13.1	13.5	16.4	16.9	
36.3	13.5	13.9	16.8	17.3	
38.3	13.8	14.3	17.1	17.6	
40.3	14.2	14.7	17.5	18.0	
42.3	14.5	15.1	17.9	18.4	
44.3	14.9	15.5	18.2	18.8	
46.3	15.3	15.8	18.6	19.2	
48.3	15.6	16.2	18.9	19.5	
50.3	16.0	16.6	19.3	19.9	
52.3	16.3	17.0	19.7	20.3	
54.3	16.7	17.4	20.0	20.7	
56.3	17.0	17.7	20.4	21.1	
58.3	17.4	18.1	20.7	21.4	
60.3	17.8	18.5	21.1	21.8	
62.3	18.1	18.9	21.4	22.2	
64.3	18.5	19.3	21.8	22.6	
66.3	18.8	19.6	22.2	23.0	

Tab. B10.01

Tie positions – installation heights

		Flex Stair with alternating staircase units																			
Structure height [m]	Number of ties	Tie installation height [m]																			
2 – 6	1																				
8 – 14	2																				
16 – 22	3																				
24 – 30	4																				
Tie forces [kN]	A $A_{ }$ A_{\perp} B $B_{ }$ B_{\perp} C	4.2	6.2	6.7	7.1																
		1.6	2.3	2.5	2.6																
		3.9	5.7	6.2	6.6																
		4.5	6.5	7.1	7.5																
		2.2	3.2	3.4	3.7																
		3.9	5.7	6.2	6.6																
		1.9	2.8	3.0	3.2																
		6 m tie spacing																			
32 – 34	6	2.5	6.5	12.5	18.5	24.5	30.5	For tie forces see Page 75													
36 – 38	7	2.5	6.5	10.5	16.5	22.5	28.5							34.5							
40 – 42	8	2.5	6.5	10.5	14.5	20.5	26.5							32.5	38.5						
44 – 46	9	2.5	6.5	10.5	14.5	18.5	24.5							30.5	36.5	42.5					
48 – 50	10	2.5	6.5	10.5	14.5	18.5	22.5							28.5	34.5	40.5	46.5				
52 – 54	11	2.5	6.5	10.5	14.5	18.5	22.5							26.5	32.5	38.5	44.5	50.5			
56 – 58	12	2.5	6.5	10.5	14.5	18.5	22.5							26.5	30.5	36.5	42.5	48.5	54.5		
60 – 62	13	2.5	6.5	10.5	14.5	18.5	22.5							26.5	30.5	34.5	40.5	46.5	52.5	58.5	
64 – 66	14	2.5	6.5	10.5	14.5	18.5	22.5							26.5	30.5	34.5	38.5	44.5	50.5	56.5	62.5

Tab. B11.01

Tension and compression-proof anchoring

Tie heights are measured without the length of the jack extension.

Height up to 30 m

Install the first tie at 2.5 m, then at spacings of 8.0 m.

Height from 32 m

Install the first tie at 2.5 m, then every 4.0 m in the lower area (marked in grey), and then every 6.0 m.

Top level

May be cantilevered to a maximum of 3.5 m!

Intermediate access on every 2nd floor

Install ties continuously every 4.0 m. Ledger Braces UBL-2 are required on the inner longitudinal side of the lower levels:

Height of 52 – 56 m: levels 1 and 2

Height of 58 – 60 m: levels 1 to 6

Height of 62 – 66 m: levels 1 to 10

Example: Stair with a height of 32 – 34 m

– 32 m: last tie at 30.5 m

– 34 m: last tie at 30.5 m

Tie forces

The tie forces have been calculated for an unclad stair tower in front of an open facade (60% openings). A wind load with the following dynamic pressures has been taken into account for the visible areas of the scaffold:

Load combination - service condition

Constant dynamic pressure:

$$q = 0.20 \text{ kN/m}^2.$$

Load combination - max. wind load

Dynamic pressure changing with height:

$$q_1 = 0.60 \text{ kN/m}^2 \text{ (at 0 m)}$$

$$q_2 = 0.77 \text{ kN/m}^2 \text{ (at 24 m) and}$$

$$q_3 = 1.05 \text{ kN/m}^2 \text{ (at 100 m)}$$

with service life factor 0.7.

With the assumed wind loads, this results in the following maximum tie forces for the various assembly heights and tie spacings (see also Tab. B11.01):

Maximum tie forces for 8 m spacing

(Height ≤ 30 m)

Triangulated tie: max. A = 7.1 kN
divided into: $A_{II} = 2.6 \text{ kN}$
 $A_{\perp} = 6.6 \text{ kN}$

max. B = 7.5 kN
divided into: $B_{II} = 3.7 \text{ kN}$
 $B_{\perp} = 6.6 \text{ kN}$

Short wall tie: max. C = 3.2 kN

Maximum tie forces for 6 m spacing

(Height ≤ 66 m)

Triangulated tie: max. A = 6.2 kN
divided into: $A_{II} = 2.3 \text{ kN}$
 $A_{\perp} = 5.8 \text{ kN}$

max. B = 6.6 kN
divided into: $B_{II} = 3.2 \text{ kN}$
 $B_{\perp} = 5.8 \text{ kN}$

Short wall tie: max. C = 2.8 kN

Maximum tie forces for 4 m spacing

(Height ≤ 66 m)

Triangulated tie: max. A = 4.1 kN
divided into: $A_{II} = 1.5 \text{ kN}$
 $A_{\perp} = 3.9 \text{ kN}$

max. B = 4.4 kN
divided into: $B_{II} = 2.1 \text{ kN}$
 $B_{\perp} = 3.9 \text{ kN}$

Short wall tie: max. C = 1.9 kN

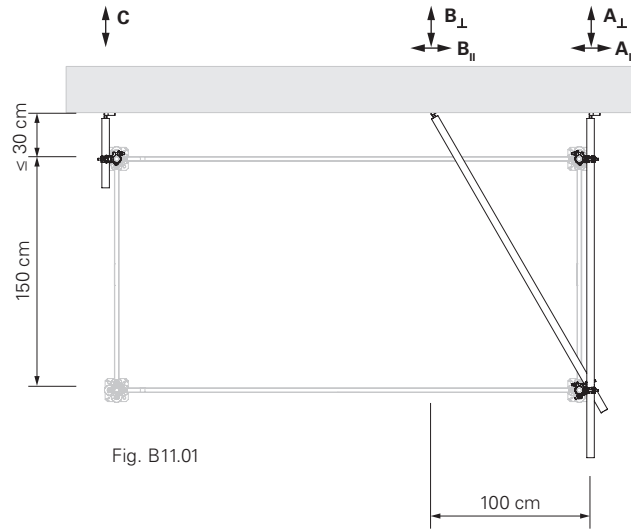

Fig. B11.01

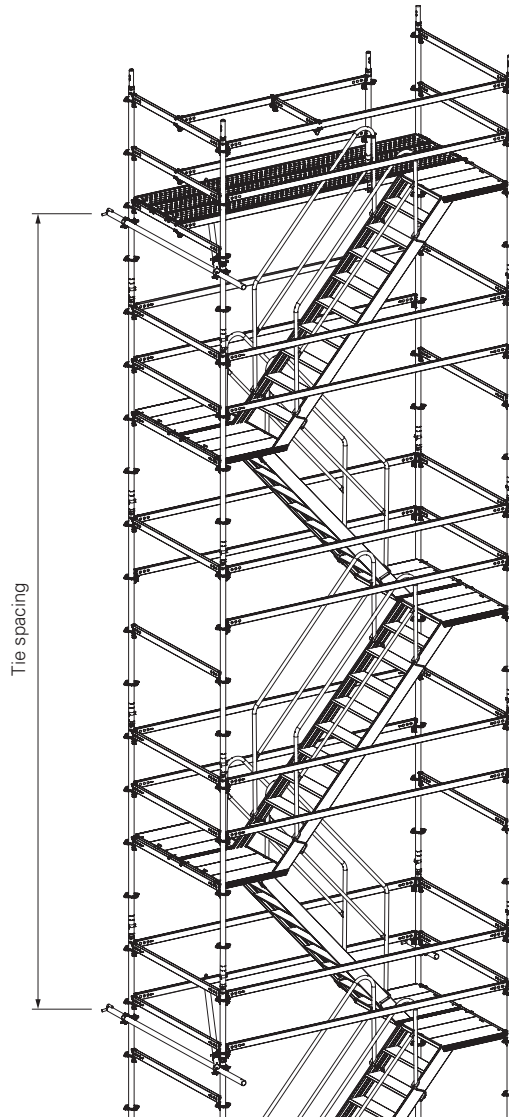

Fig. B11.02

Preparation



Warning

Heavy suspended loads!
Falling parts can result in serious injury or even death

- ⇒ Ensure that all standards are tightly connected.
- ⇒ Remove the lifting gear from a safe working position.
- ⇒ Only attach to the rosette nodes which are directly connected to the horizontal ledgers.

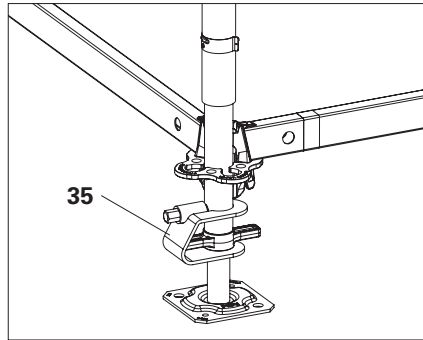

Fig. C1.01

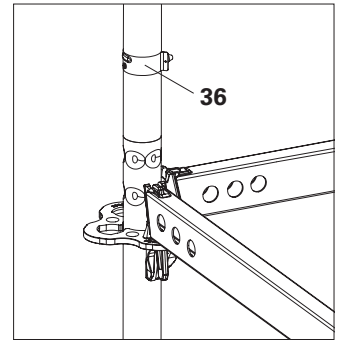

Fig. C1.02



The stability of stair towers must be ensured at all times:

- during assembly,
- when attaching to and disconnecting from the crane,
- at the place of installation and use.
- For crane relocation purposes, spindle out the Base Spindle UJB by at least 17 cm. This is the only way to ensure a tension-proof connection between the Base Standard UVB and the Standard UVR-2 with locking pins.

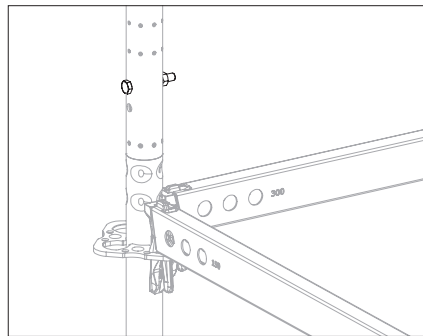

Fig. C1.03

Components

- 3** Horizontal Ledger UH-2 300
- 35** Spindle Locking UJS
- 36** Locking pin Ø 48/57

Assembly

1. Secure Base Spindles UJB with Spindle Locking UJS (**11**). (Fig. C1.01)
2. Connect the Standards UVR-2 (**12**) with locking pins (**12**) so that they are tension-proof. (Fig. C1.02)
Alternatively: Use bolt M 10 x 70 with nut.

3. Brace the top level with an additional horizontal ledger (**3**).
4. Attach using suitable lifting gear (e.g. round slings) as shown in the figure and lift with the crane Stop angle max. 60° . (Fig. C1.04a)

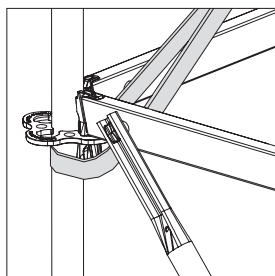

Fig. C1.04a

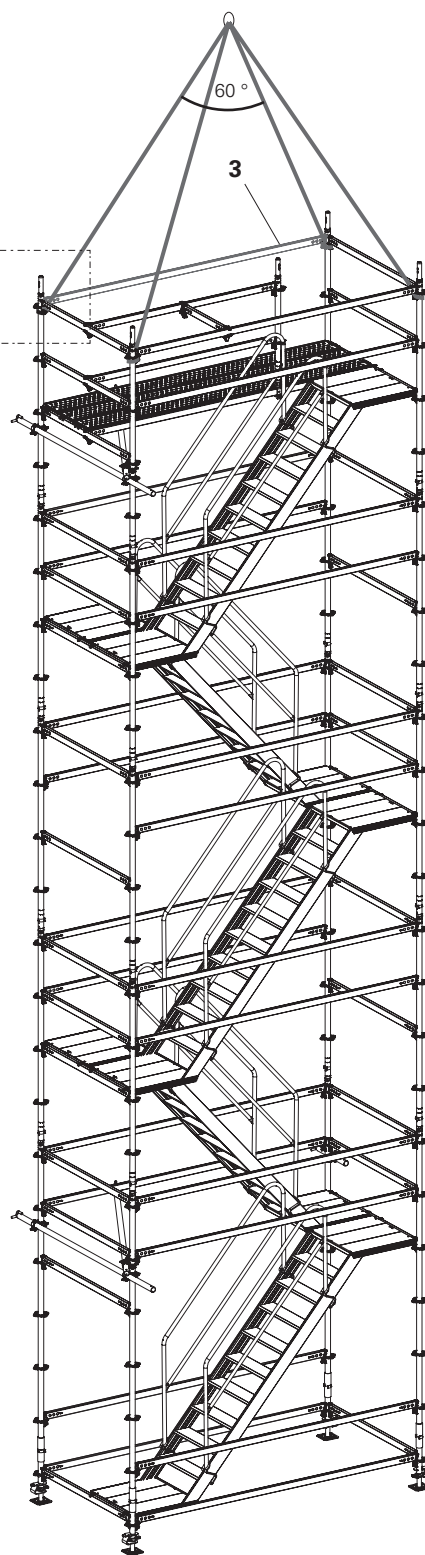

Fig. C1.04

PERI UP Flex Stair 75

Art. no.	Weight [kg]	
100411	3.390	BASE SPINDLE UJB 38-50/30

Note

With captive red quick jack nut.

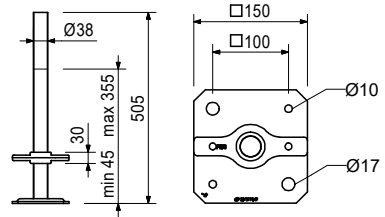

Accessories (not included)

100863	1.020	SPINDLE LOCKING UJS
--------	-------	----------------------------

Art. no.	Weight [kg]	
100242	4.570	BASE SPINDLE UJB 38-80/55

Note

With captive yellow quick jack nut.

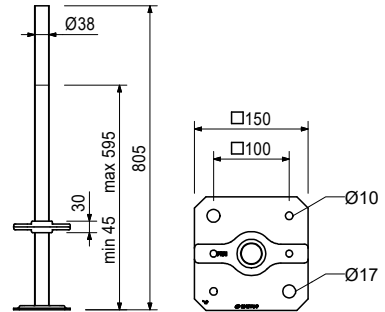
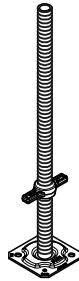

Accessories (not included)

100863	1.020	SPINDLE LOCKING UJS
--------	-------	----------------------------

Art. no.	Weight [kg]	
100863	1.020	SPINDLE LOCKING UJS

Locks base spindles and section spindles Ø 38 mm in the vertical during moving procedures.

Note

Permissible load 1.5 kN.

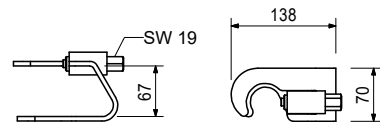

PERI UP Flex Stair 75

Art. no.	Weight [kg]	
133499	2.260	BASE STANDARD UVB 25

For assembling directly onto the base spindles.
Can also be used as 25 cm standard.

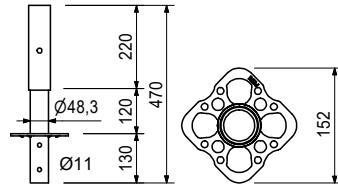
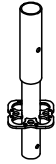

Art. no.	Weight [kg]	
400014	2.470	BASE STANDARD UVB 24

For assembling directly onto the base spindles.

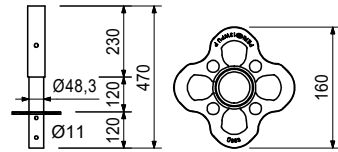
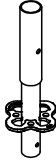

Art. no.	Weight [kg]	
135187	3.580	BASE STANDARD UVB 50

For assembling directly onto the base spindles.
Can also be used as 50 cm standard.

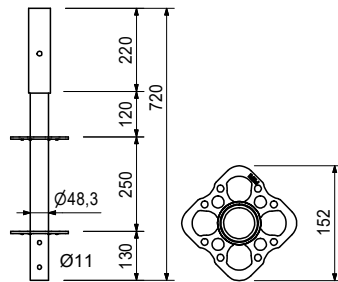

Art. no.	Weight [kg]	
417194	3.980	BASE STANDARD UVB 49

For assembling directly onto the base spindles. Reduces necessary spindle extensions with 25 cm rosette spacing.

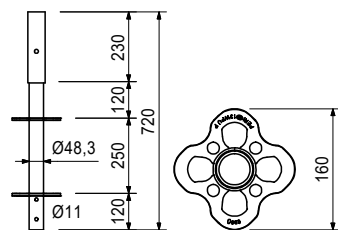

PERI UP Flex Stair 75



Art. no.	Weight [kg]		L [mm]
		Top Standards UVH-2	
132123	2.100	TOP STANDARD UVH-2 50	500
132194	4.210	TOP STANDARD UVH-2 100	1,000
132198	6.320	TOP STANDARD UVH-2 150	1,500
132200	8.420	TOP STANDARD UVH-2 200	2,000
132202	10.500	TOP STANDARD UVH-2 250	2,500

Without pin for mounting head spindles.

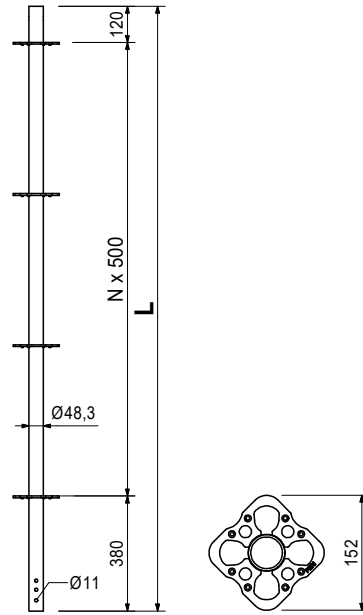

Art. no.	Weight [kg]		L [mm]
		Top Standards UVH	
401309	2.510	TOP STANDARD UVH 50	500
400000	4.610	TOP STANDARD UVH 100	1,000
400003	6.920	TOP STANDARD UVH 150	1,500
400005	9.230	TOP STANDARD UVH 200	2,000
400007	11.500	TOP STANDARD UVH 250	2,500

Without pin for mounting head spindles.

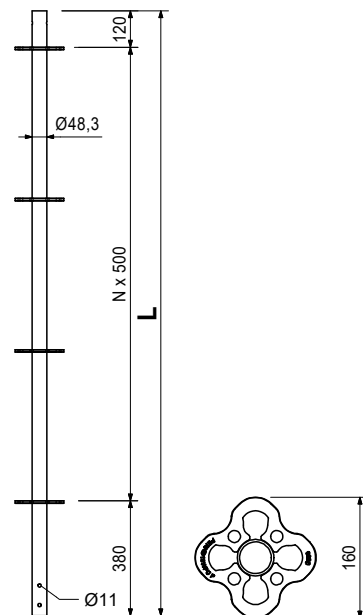

PERI UP Flex Stair 75



Art. no.	Weight [kg]		L [mm]
132196	6.070	TOP STANDARD UVH-2 125	1,250

Without pin for mounting head spindles.

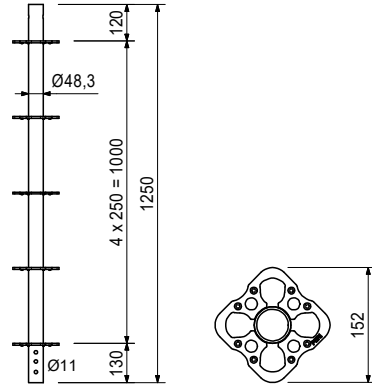

Art. no.	Weight [kg]		L [mm]
417195	7.590	TOP STANDARD UVH 125	1,250

Without pin for mounting head spindles. Reduces necessary spindle extensions with 25 cm rosette spacing.

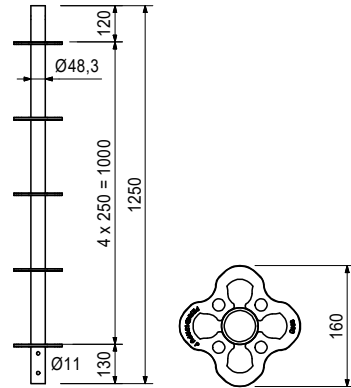

Art. no.	Weight [kg]		L [mm]
		Standards UVR	
402859	3.080	STANDARD UVR 50	500
401306	5.380	STANDARD UVR 100	1,000
402860	7.690	STANDARD UVR 150	1,500
400009	9.990	STANDARD UVR 200	2,000
400012	14.700	STANDARD UVR 300	3,000

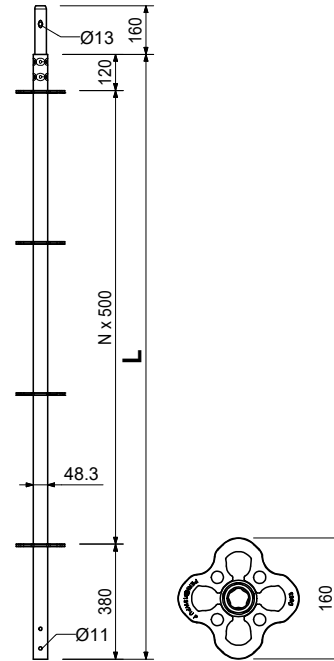
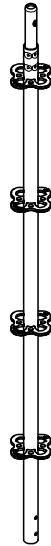

Art. no.	Weight [kg]		L [mm]	X [mm]
		Horizontal Ledger UH-2		
131995	1.400	HORIZONTAL LEDGER UH-2 25	204	250
133900	1.590	HORIZONTAL LEDGER UH-2 33	284	330
131998	2.030	HORIZONTAL LEDGER UH-2 50	454	500
133903	2.470	HORIZONTAL LEDGER UH-2 67	624	670
132213	2.680	HORIZONTAL LEDGER UH-2 75	704	750
132004	3.730	HORIZONTAL LEDGER UH-2 100	954	1,000
132007	4.500	HORIZONTAL LEDGER UH-2 125	1,204	1,250
132010	4.670	HORIZONTAL LEDGER UH-2 150	1,454	1,500
132013	5.330	HORIZONTAL LEDGER UH-2 175	1,704	1,750
132016	5.990	HORIZONTAL LEDGER UH-2 200	1,954	2,000
132019	6.650	HORIZONTAL LEDGER UH-2 225	2,204	2,250
132025	7.310	HORIZONTAL LEDGER UH-2 250	2,454	2,500
132022	8.640	HORIZONTAL LEDGER UH-2 300	3,954	3,000

Note

With length marking for easier identification.

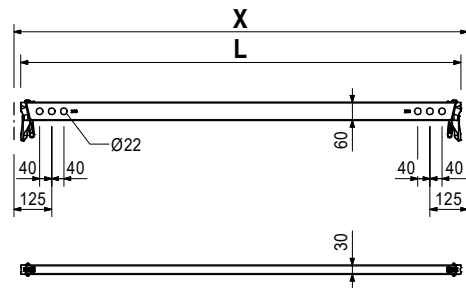
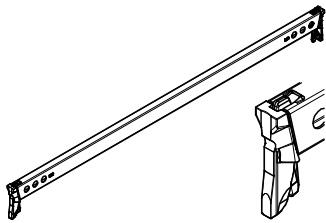

Art. no.	Weight [kg]		L [mm]	X [mm]
		Horizontal Ledger UH Plus		
414613	1.430	HORIZONTAL LEDGER UH 25 PLUS	204	250
414595	2.080	HORIZONTAL LEDGER UH 50 PLUS	454	500
429982	2.520	HORIZONTAL LEDGER UH 67 PLUS	624	670
414629	2.740	HORIZONTAL LEDGER UH 75 PLUS	704	750
414632	4.470	HORIZONTAL LEDGER UH 100 PLUS	954	1,000
414638	5.440	HORIZONTAL LEDGER UH 125 PLUS	1,204	1,250
414641	4.720	HORIZONTAL LEDGER UH 150 PLUS	1,454	1,500
417032	5.390	HORIZONTAL LEDGER UH 175 PLUS	1,704	1,750
414645	6.050	HORIZONTAL LEDGER UH 200 PLUS	1,954	2,000
416356	6.710	HORIZONTAL LEDGER UH 225 PLUS	2,204	2,250
414648	7.370	HORIZONTAL LEDGER UH 250 PLUS	2,454	2,500
414651	8.690	HORIZONTAL LEDGER UH 300 PLUS	3,954	3,000

Note

With length marking for easier identification.

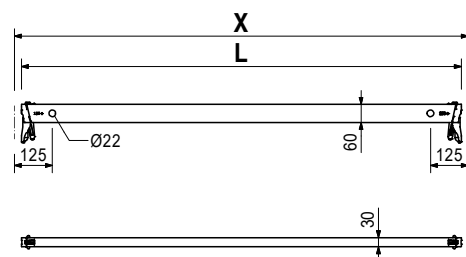
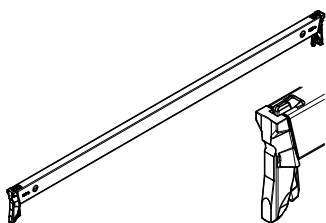

PERI UP Flex Stair 75



Art. no.	Weight [kg]	
130681	1.360	UH SPIGOT-2

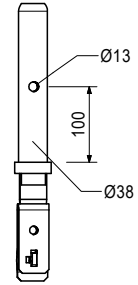
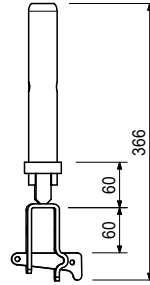
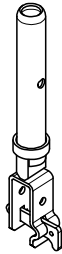

Art. no.	Weight [kg]	
409764	1.220	UH SPIGOT

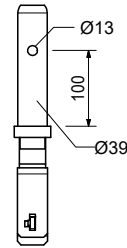
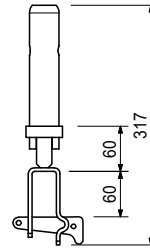
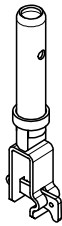

Art. no.	Weight [kg]	
136582	0.831	LEDGER-TO-LEDGER COUPLER UHA-2

For connecting horizontal ledgers at right-angles.

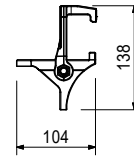
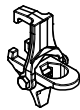

Art. no.	Weight [kg]	
401731	0.841	LEDGER-TO-LEDGER COUPLER UHA

For right-angled connection of Horizontal ledgers on horizontal ledgers.

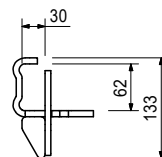

Art. no.	Weight [kg]	
130684	2.020	LEDGER-TO-LEDGER COUPLER UHA-2 HALF WITH SPIGOT

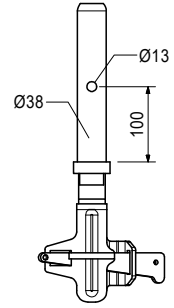
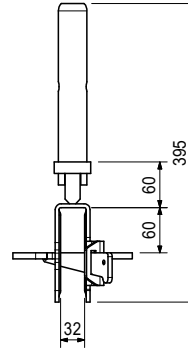
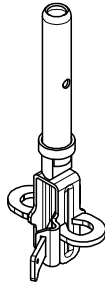

Art. no.	Weight [kg]	
410792	1.880	LEDGER-TO-LEDGER COUPLER UHA HALF WITH SPIGOT

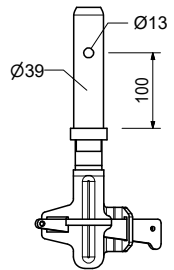
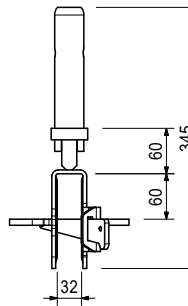
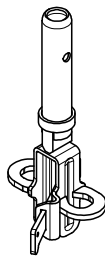

Art. no.	Weight [kg]		L [mm]	X [mm]	Y [mm]
Ledger Braces UBL-2					
132771	2.140	LEDGER BRACE UBL-2 100/50	901	1,000	500
132773	2.830	LEDGER BRACE UBL-2 100/100	1,290	1,000	1,000
132775	3.680	LEDGER BRACE UBL-2 100/150	1,677	1,000	1,500
132777	4.600	LEDGER BRACE UBL-2 100/200	2,136	1,000	2,000
132779	3.030	LEDGER BRACE UBL-2 150/50	1,347	1,500	500
132781	3.530	LEDGER BRACE UBL-2 150/100	1,601	1,500	1,000
132783	4.230	LEDGER BRACE UBL-2 150/150	1,953	1,500	1,500
132785	5.040	LEDGER BRACE UBL-2 150/200	2,358	1,500	2,000
132787	5.330	LEDGER BRACE UBL-2 175/200	2,500	1,750	2,000
132789	3.970	LEDGER BRACE UBL-2 200/50	1,820	2,000	500
132791	4.360	LEDGER BRACE UBL-2 200/100	2,016	2,000	1,000
132793	4.940	LEDGER BRACE UBL-2 200/150	2,305	2,000	1,500
132795	5.640	LEDGER BRACE UBL-2 200/200	2,658	2,000	2,000
132797	4.450	LEDGER BRACE UBL-2 225/50	2,062	2,250	500
132808	4.800	LEDGER BRACE UBL-2 225/100	2,236	2,250	1,000
132810	5.980	LEDGER BRACE UBL-2 225/200	2,829	2,250	2,000
132812	5.250	LEDGER BRACE UBL-2 250/100	2,462	2,500	1,000
132814	5.730	LEDGER BRACE UBL-2 250/150	2,705	2,500	1,500
132816	6.340	LEDGER BRACE UBL-2 250/200	3,010	2,500	2,000
132827	5.920	LEDGER BRACE UBL-2 300/50	2,795	3,000	500
132829	6.180	LEDGER BRACE UBL-2 300/100	2,926	3,000	1,000
132831	6.590	LEDGER BRACE UBL-2 300/150	3,133	3,000	1,500
132833	7.120	LEDGER BRACE UBL-2 300/200	3,400	3,000	2,000

They are attached using holes in the horizontal ledgers.

Note

Longitudinally-stamped with coloured label for easier identification.

UBL-2 150/250 identical to UBL-2 300/50.

UBL-2 225/150 identical to UBL-2 175/200.

UBL-2 250/50 identical to UBL-2 200/150

UBL-2 75/200 identical to UBL-2 225/50.

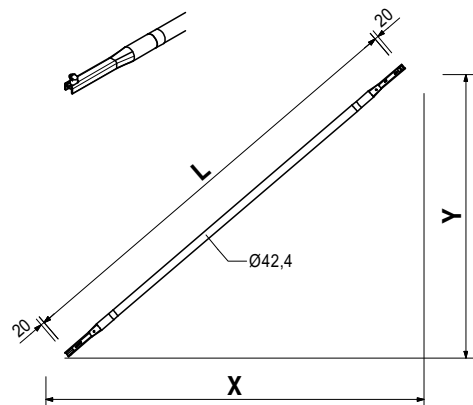
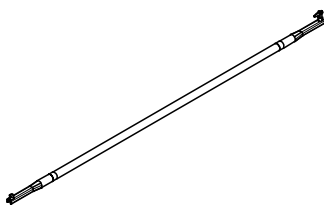

Art. no.	Weight [kg]		L [mm]	X [mm]	Y [mm]
Ledger Braces UBL					
415156	2.660	LEDGER BRACE UBL 100/50	901	1,000	500
415513	4.640	LEDGER BRACE UBL 100/150	1,677	1,000	1,500
415157	5.810	LEDGER BRACE UBL 100/200	2,136	1,000	2,000
407867	3.790	LEDGER BRACE UBL 150/50	1,347	1,500	500
400055	4.440	LEDGER BRACE UBL 150/100	1,601	1,500	1,000
402846	5.340	LEDGER BRACE UBL 150/150	1,953	1,500	1,500
400057	6.380	LEDGER BRACE UBL 150/200	2,358	1,500	2,000
409034	6.740	LEDGER BRACE UBL 175/200	2,500	1,750	2,000
404391	5.000	LEDGER BRACE UBL 200/50	1,820	2,000	500
400059	5.500	LEDGER BRACE UBL 200/100	2,016	2,000	1,000
402862	6.240	LEDGER BRACE UBL 200/150	2,305	2,000	1,500
400061	7.160	LEDGER BRACE UBL 200/200	2,658	2,000	2,000
430282	4.450	LEDGER BRACE UBL 225/50	2,062	2,250	500
430283	4.800	LEDGER BRACE UBL 225/100	2,236	2,250	1,000
417689	7.580	LEDGER BRACE UBL 225/200	2,829	2,250	2,000
400063	6.640	LEDGER BRACE UBL 250/100	2,462	2,500	1,000
402861	7.260	LEDGER BRACE UBL 250/150	2,705	2,500	1,500
400065	8.050	LEDGER BRACE UBL 250/200	3,010	2,500	2,000
404762	7.490	LEDGER BRACE UBL 300/50	2,795	3,000	500
400067	7.830	LEDGER BRACE UBL 300/100	2,926	3,000	1,000
404766	8.360	LEDGER BRACE UBL 300/150	3,133	3,000	1,500
400069	9.050	LEDGER BRACE UBL 300/200	3,400	3,000	2,000

Note

Longitudinally-stamped with coloured label for easier identification.

UBL 150/250 identical to UBL 300/50.

UBL 225/150 identical to UBL 175/200.

UBL 250/50 identical to UBL 200/150

UBL 75/200 identical to UBL 225/50.

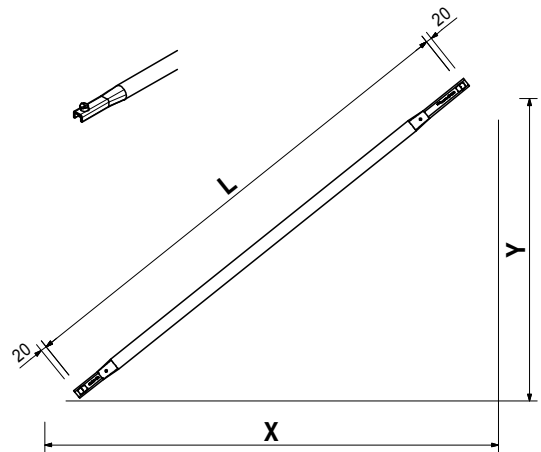
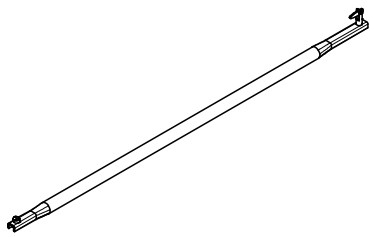

Art. no.	Weight [kg]		L [mm]	X [mm]	Y [mm]
Node Braces UBK-2					
133418	4.980	NODE BRACE UBK-2 75/200	2,190	750	2,000
133421	5.130	NODE BRACE UBK-2 100/200	2,285	1,000	2,000
133424	3.900	NODE BRACE UBK-2 125/100	1,625	1,250	1,000
133427	5.320	NODE BRACE UBK-2 125/200	2,401	1,250	2,000
133430	4.240	NODE BRACE UBK-2 150/100	1,821	1,500	1,000
133433	4.840	NODE BRACE UBK-2 150/150	2,152	1,500	1,500
133436	5.550	NODE BRACE UBK-2 150/200	2,539	1,500	2,000
133439	4.990	NODE BRACE UBK-2 200/100	2,246	2,000	1,000
133442	5.490	NODE BRACE UBK-2 200/150	2,521	2,000	1,500
133445	6.100	NODE BRACE UBK-2 200/200	2,860	2,000	2,000
133448	5.790	NODE BRACE UBK-2 250/100	2,696	2,500	1,000
133451	6.210	NODE BRACE UBK-2 250/150	2,930	2,500	1,500
133454	6.740	NODE BRACE UBK-2 250/200	3,226	2,500	2,000
133457	6.620	NODE BRACE UBK-2 300/100	3,131	3,000	1,000
133460	6.980	NODE BRACE UBK-2 300/150	3,356	3,000	1,500
133463	7.440	NODE BRACE UBK-2 300/200	3,625	3,000	2,000

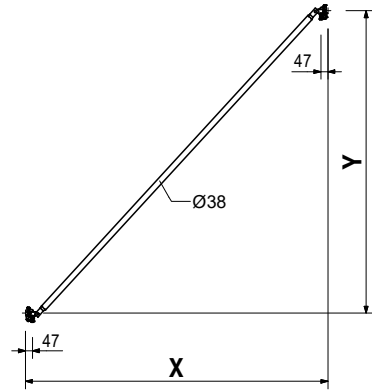
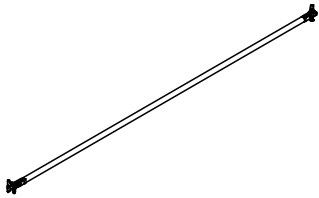

Art. no.	Weight [kg]		L [mm]	X [mm]	Y [mm]
Node Braces UBK					
424170	6.780	NODE BRACE UBK 75/200	2,190	750	2,000
412926	6.990	NODE BRACE UBK 100/200	2,285	1,000	2,000
415354	5.220	NODE BRACE UBK 125/100	1,625	1,250	1,000
412765	7.260	NODE BRACE UBK 125/200	2,401	1,250	2,000
400981	5.710	NODE BRACE UBK 150/100	1,821	1,500	1,000
400973	6.580	NODE BRACE UBK 150/150	2,152	1,500	1,500
400572	7.600	NODE BRACE UBK 150/200	2,539	1,500	2,000
400985	6.790	NODE BRACE UBK 200/100	2,246	2,000	1,000
406630	7.510	NODE BRACE UBK 200/150	2,521	2,000	1,500
400573	8.390	NODE BRACE UBK 200/200	2,860	2,000	2,000
400989	7.940	NODE BRACE UBK 250/100	2,696	2,500	1,000
406624	8.540	NODE BRACE UBK 250/150	2,930	2,500	1,500
400574	9.310	NODE BRACE UBK 250/200	3,226	2,500	2,000
400993	9.130	NODE BRACE UBK 300/100	3,131	3,000	1,000
400575	10.300	NODE BRACE UBK 300/200	3,625	3,000	2,000

Note

With length marking for easier identification.

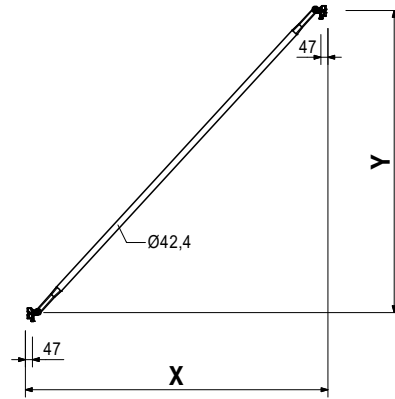
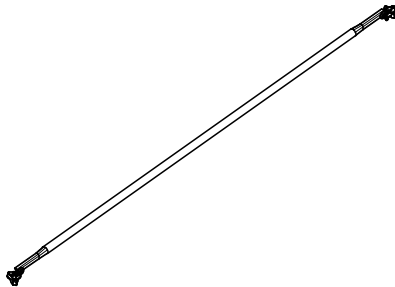

Art. no.	Weight [kg]	
100742	10.000	STAIR GUARDRAIL UAG

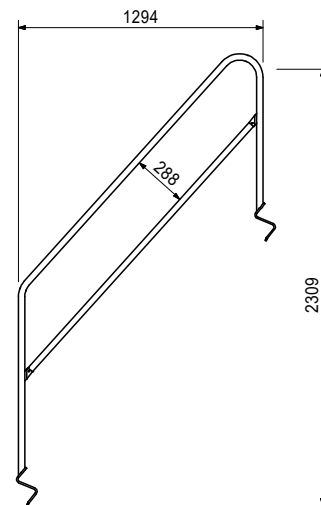
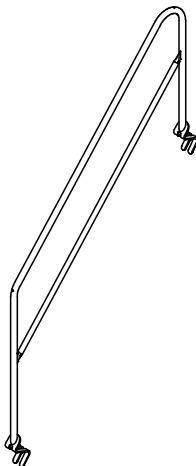

PERI UP Flex Stair 75

Art. no.	Weight [kg]	
133543	4.510	STAIR GUARDRAIL UAH-2

For fixing to the stringers of the Staircases UAS, UAS-2 and EAS.

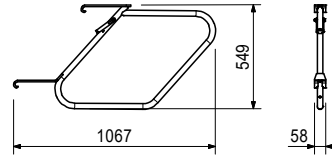

Art. no.	Weight [kg]	
400830	4.970	GUARDRAIL UAH

For fixing to the stringers, but only of Staircases UAS.

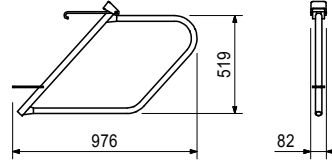
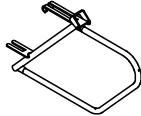

Art. no.	Weight [kg]	
134556	11.800	FLEX STAIRCASE UAS-2 75x75/50

Fit onto Horizontal Ledger UH.

Note

Class B according to DIN EN 12811-1.

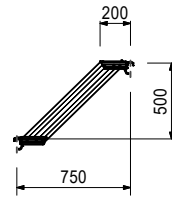
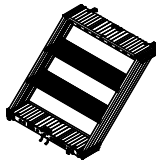

Art. no.	Weight [kg]	
134563	17.300	FLEX STAIR UAS-2 75x150/50T

Fit onto Horizontal Ledger UH.

Note

Class B according to DIN EN 12811-1.

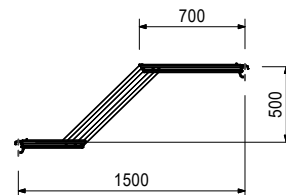
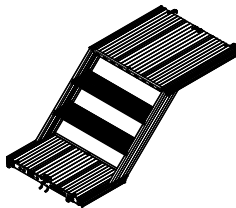

PERI UP Flex Stair 75



Art. no.	Weight [kg]	
134564	17.300	FLEX STAIR UAS-2 75x150/50S

Fit onto Horizontal Ledger UH.

Note

Class B according to DIN EN 12811-1.

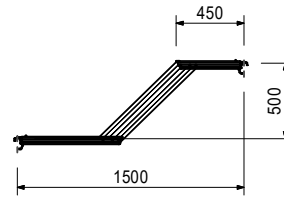

Art. no.	Weight [kg]	
134557	18.200	FLEX STAIR UAS-2 75x150/100T

Fit onto Horizontal Ledger UH.

Note

Class B according to DIN EN 12811-1.

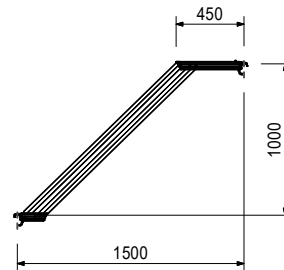
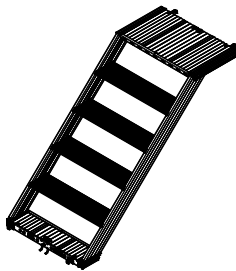

Art. no.	Weight [kg]	
134558	18.200	FLEX STAIR UAS-2 75x150/100S

Fit onto Horizontal Ledger UH.

Note

Class B according to DIN EN 12811-1.

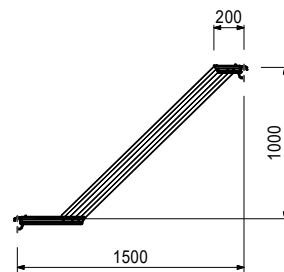
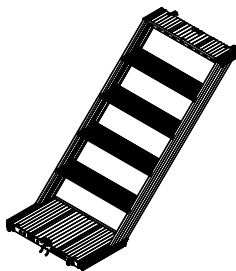

PERI UP Flex Stair 75



Art. no.	Weight [kg]	
134562	29.700	FLEX STAIRCASE UAS-2 75x250/200

Fit onto Horizontal Ledger UH.

Note

Class B according to DIN EN 12811-1.

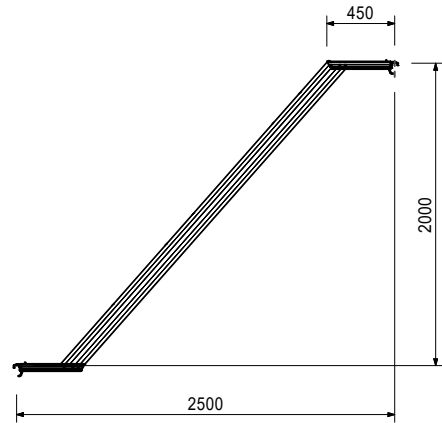

Art. no.	Weight [kg]	
134561	33.300	FLEX STAIRCASE UAS-2 75X300/200

Fit onto Horizontal Ledger UH.

Note

Class B according to DIN EN 12811-1.

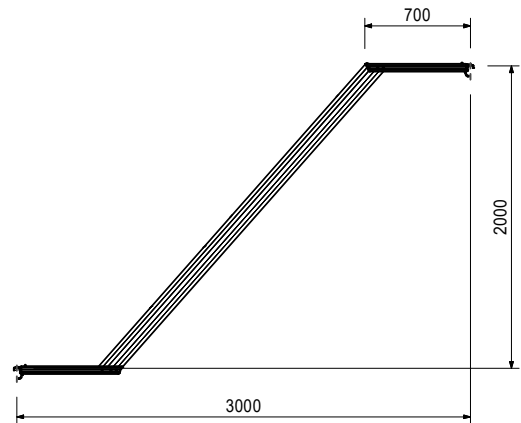
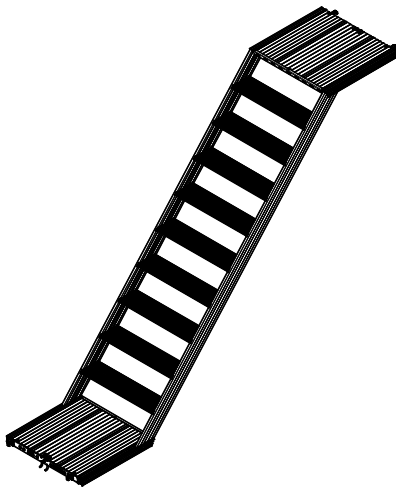

PERI UP Flex Stair 75

Art. no.	Weight [kg]	
		Stair Tower UAS 75, Aluminium
411117	28.000	STAIR TOWER UAS 75X250/200
411124	32.900	STAIR TOWER UAS 75X300/200

Fit onto Horizontal Ledgers UH.

Note

Load Class 3 = 2.0 kN/m².

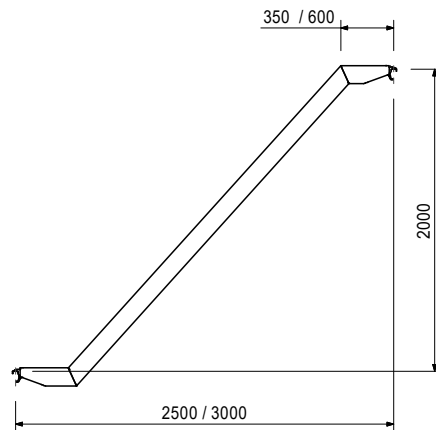
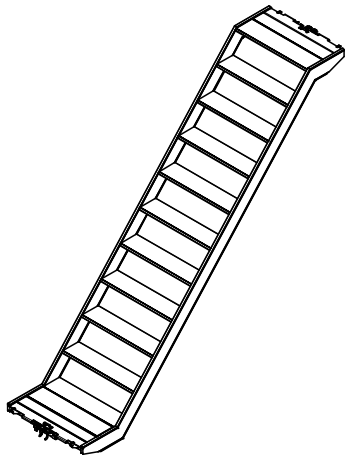

Art. no.	Weight [kg]	
413228	10.100	STAIR TOWER UAS 75X75/50

Fit onto Horizontal Ledgers UH.

Note

Load Class 3 = 2.0 kN/m².

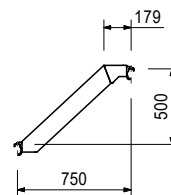
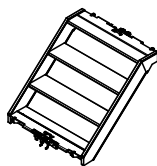

Art. no.	Weight [kg]	
411087	17.500	STAIR TOWER UAS 75X150/50 T

Fit onto Horizontal Ledgers UH.

Note

Load Class 3 = 2.0 kN/m².

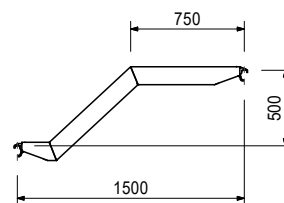
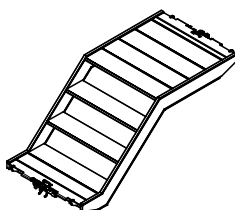

PERI UP Flex Stair 75

Art. no.	Weight [kg]	
411095	17.500	STAIR TOWER UAS 75X150/50 S

Fit onto Horizontal Ledgers UH.

Note

Load Class 3 = 2.0 kN/m².

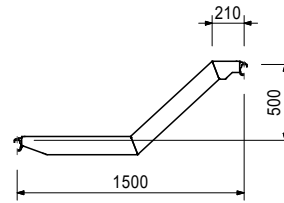
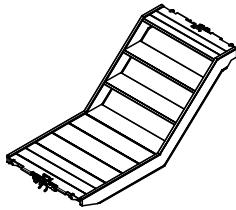

Art. no.	Weight [kg]	
411103	17.900	STAIR TOWER UAS 75X150/100

Fit onto Horizontal Ledgers UH.

Note

Load Class 3 = 2.0 kN/m².

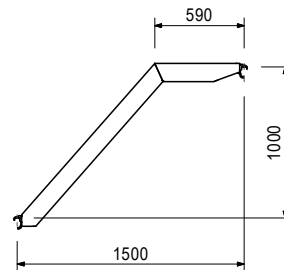
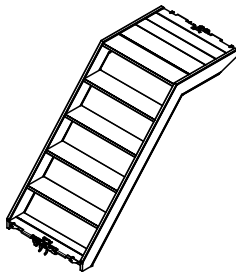

Art. no.	Weight [kg]	
414536	17.900	STAIR TOWER UAS 75X150/100 S

Fit onto Horizontal Ledgers UH.

Note

Load Class 3 = 2.0 kN/m².

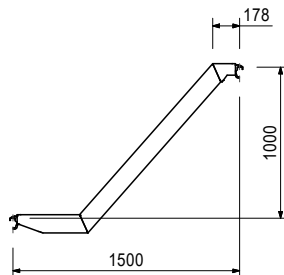
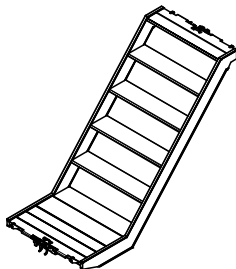

Art. no.	Weight [kg]	
415189	3.080	WALER ON STAIRCASE UAS 75

Mounted on the steps of the stair tower. Enables attachment of Decks UDI or UDG.

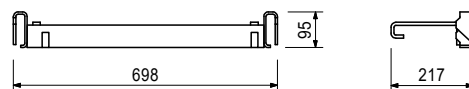
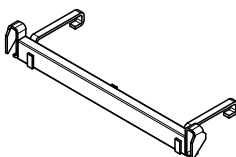

Art. no.	Weight [kg]		X [mm]	perm. p [kN]
Steel Decks UDG-2 25				
132479	3.190	STEEL DECK UDG-2 25X 50	500	6
132483	3.960	STEEL DECK UDG-2 25X 67	670	6
132488	4.320	STEEL DECK UDG-2 25X 75	750	6
132492	5.450	STEEL DECK UDG-2 25X100	1,000	6
132502	6.590	STEEL DECK UDG-2 25X125	1,250	6
132505	7.730	STEEL DECK UDG-2 25X150	1,500	6
132508	10.500	STEEL DECK UDG-2 25X200	2,000	6
132511	12.900	STEEL DECK UDG-2 25X250	2,500	4.5
132515	15.800	STEEL DECK UDG-2 25X300	3,000	3

Length X: 500 - 1,500 with H of 45 mm.
 Length X: 2,000 - 2,500 with H of 60 mm.
 Length X: 3,000 with H of 70 mm.

Note

Values correspond with EN 12811-1.

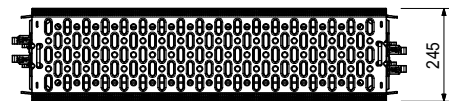
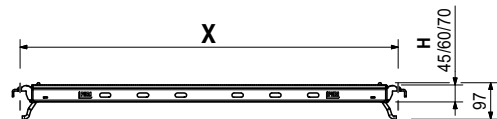
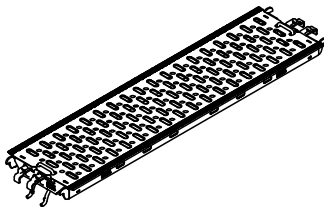

Art. no.	Weight [kg]		X [mm]	perm. p [kN]
Steel Decks UDG 25				
424124	3.810	STEEL DECK UDG 25X 50	500	6
432858	4.810	STEEL DECK UDG 25X 67	670	6
424121	5.180	STEEL DECK UDG 25X 75	750	6
424118	6.550	STEEL DECK UDG 25X100	1,000	6
424115	7.940	STEEL DECK UDG 25X125	1,250	6
424112	9.330	STEEL DECK UDG 25X150	1,500	6
424109	12.200	STEEL DECK UDG 25X200	2,000	6
423771	14.900	STEEL DECK UDG 25X250	2,500	4.5
424915	17.700	STEEL DECK UDG 25X300	3,000	3

Fit onto Horizontal Ledgers UH.

Note

Values correspond with EN 12811-1.
 max. p = max. possible surface load without deflection limitation.

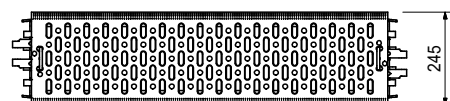
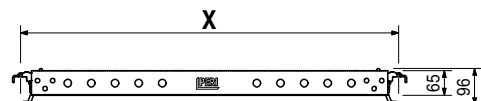
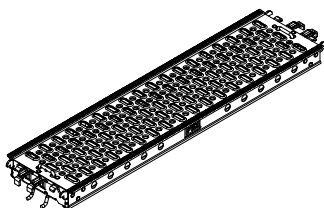

PERI UP Flex Stair 75

Art. no.	Weight [kg]	
412717	7.000	BRACKET BRACE UCM

To increase the load-bearing capacity of console brackets UCM 50 and UCM 75 with yellow coupling.



Art. no.	Weight [kg]	
412678	6.510	CONSOLE BRACKET UCM 75 WITH SPIGOT

With connection for Console Bracket Brace UCM.

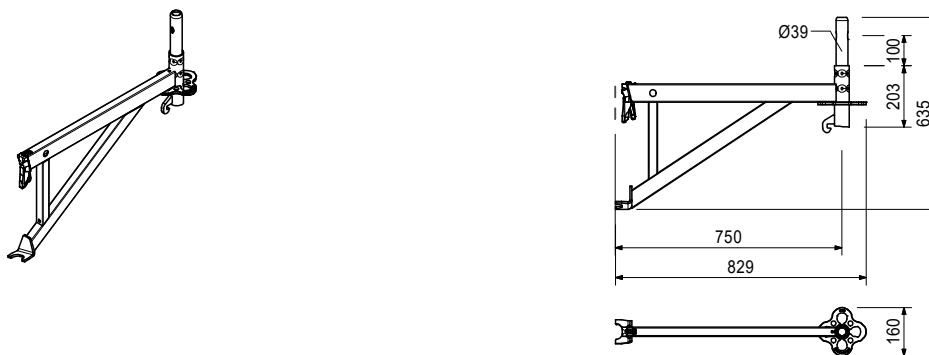

Art. no.	Weight [kg]	
136918	8.000	CONSOLE BRACKET ECM 75

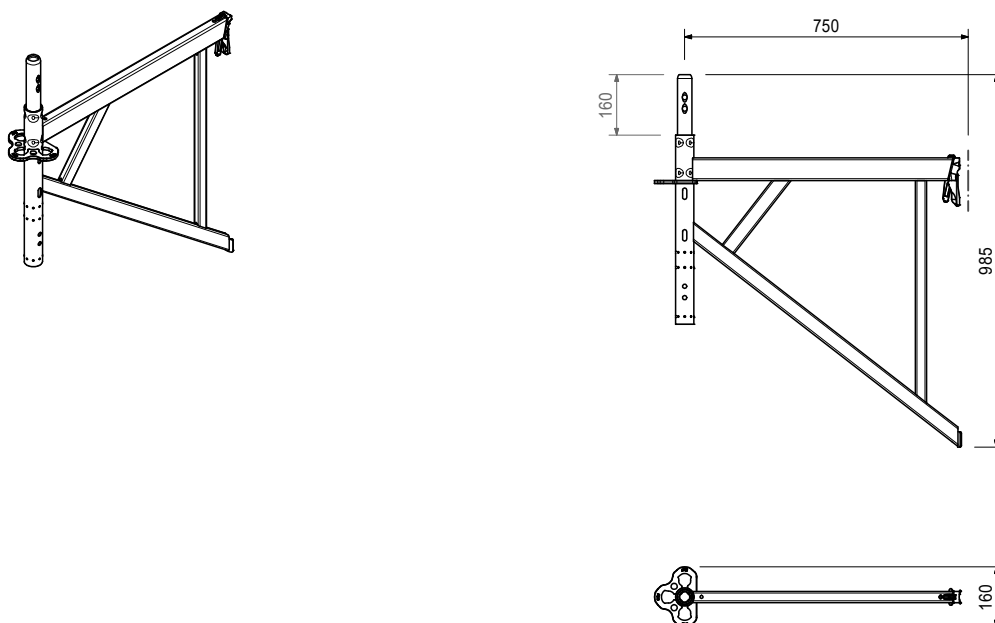

Art. no.	Weight [kg]	
		Steel scaffolding tube Ø 48.3 x 3.2
026415	3.550	SCAFFOLDING TUBE 48.3X3.2 LM-GALV
026411	3.550	SCAFFOLDING TUBE 48.3X3.2X1000 GALV
026412	7.100	SCAFFOLDING TUBE 48.3X3.2X2000 GALV
026413	10.650	SCAFFOLDING TUBE 48.3X3.2X3000 GALV
026414	14.200	SCAFFOLDING TUBE 48.3X3.2X4000 GALV
026419	17.750	SCAFFOLDING TUBE 48.3X3.2X5000 GALV
026418	21.600	SCAFFOLDING TUBE 48.3X3.2X6000 GALV
026417	0.000	CUTTING COSTS F. SCAFFOLDING TUBES

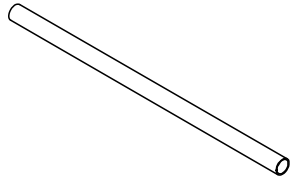

Art. no.	Weight [kg]	
017010	1.400	SWIVEL COUPLING AF 48/48, GALV.

For scaffolding tubes Ø 48 mm.

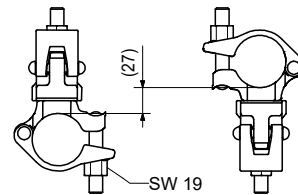
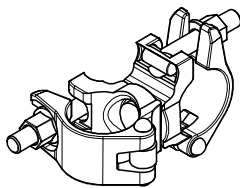

Art. no.	Weight [kg]	
017020	1.120	STANDARD COUPLER RA 48/48, GALV.

For scaffolding tubes Ø 48 mm.

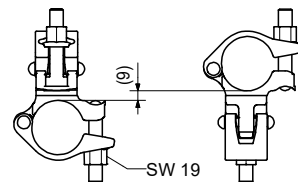
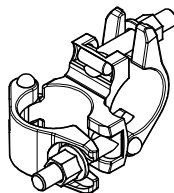

Art. no.	Weight [kg]	
111053	0.059	LOCKING PIN D48/D57

As tension-proof connection of standards with a diameter of 48 up to 57 mm.

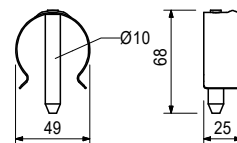

PERI UP Flex Stair 75



Art. no.	Weight [kg]	
100719	0.060	BOLT.ISO4014-M10X070-8.8-VZ-MU
138009	0.060	BOLT.ISO4014-M10X070-10.9-VZ-MU

As tension-proof connection of standards at suspended scaffolds and formwork girders.

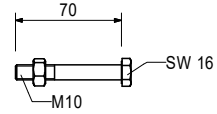
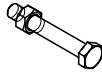

Art. no.	Weight [kg]		L [mm]
Wall Tie UWT			
100088	1.920	WALL TIE UWT 45	488
100091	4.680	WALL TIE UWT 110	1,138
100093	5.870	WALL TIE UWT 140	1,438
102951	7.060	WALL TIE UWT 170	1,738
102954	9.050	WALL TIE UWT 220	2,238
102957	11.000	WALL TIE UWT 270	2,738

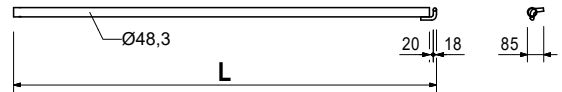
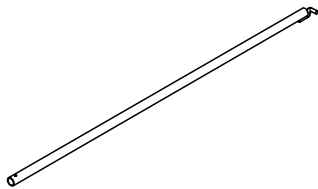

Art. no.	Weight [kg]	
Eyebolts UFE		
100693	0.169	EYEBOLT UFE 12/90
100694	0.190	EYEBOLT UFE 12/120
100695	0.250	EYEBOLT UFE 12/190

For assembly of the Wall Tie UWT.
Required Expanding Dowel UFI 14.

Note

With marking for screw-in depth.

Art. no.	Weight [kg]	
Expanding Dowel UFI		
100696	0.007	EXPANDING DOWEL UFI 14/70
100697	0.009	EXPANDING DOWEL UFI 14/100
100698	0.010	EXPANDING DOWEL UFI 14/135

PERI UP Flex Stair 75



Art. no.	Weight [kg]		L [mm]	X [mm]
Guardrail Posts EPG				
130195	2.480	GUARDRAIL POST EPG 150	1,565	1,500
130197	3.280	GUARDRAIL POST EPG 200	2,065	2,000
130199	4.090	GUARDRAIL POST EPG 250	2,565	2,500
130201	4.890	GUARDRAIL POST EPG 300	3,065	3,000

Note

With length marking for easier identification.

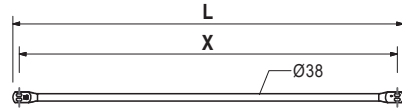
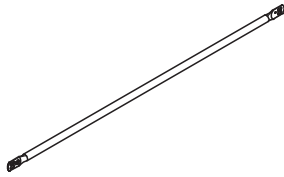

Art. no.	Weight [kg]	
130562	0.623	GUARDRAIL HOLDER EPW

For installing the Guardrail Posts EPG to rosettes.

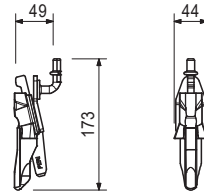

Art. no.	Weight [kg]	
113832	0.035	PERI UP SCAFFOLD TAG

For cordoning off scaffolding areas not yet authorised for use. With the exception of inserting the PERI UP Assembly Certificates.



PERI UP Flex

Stairs 75

Instructions for Assembly and Dismantling – Short lift system to NASC SG4:15 – Edition 01 | 2019

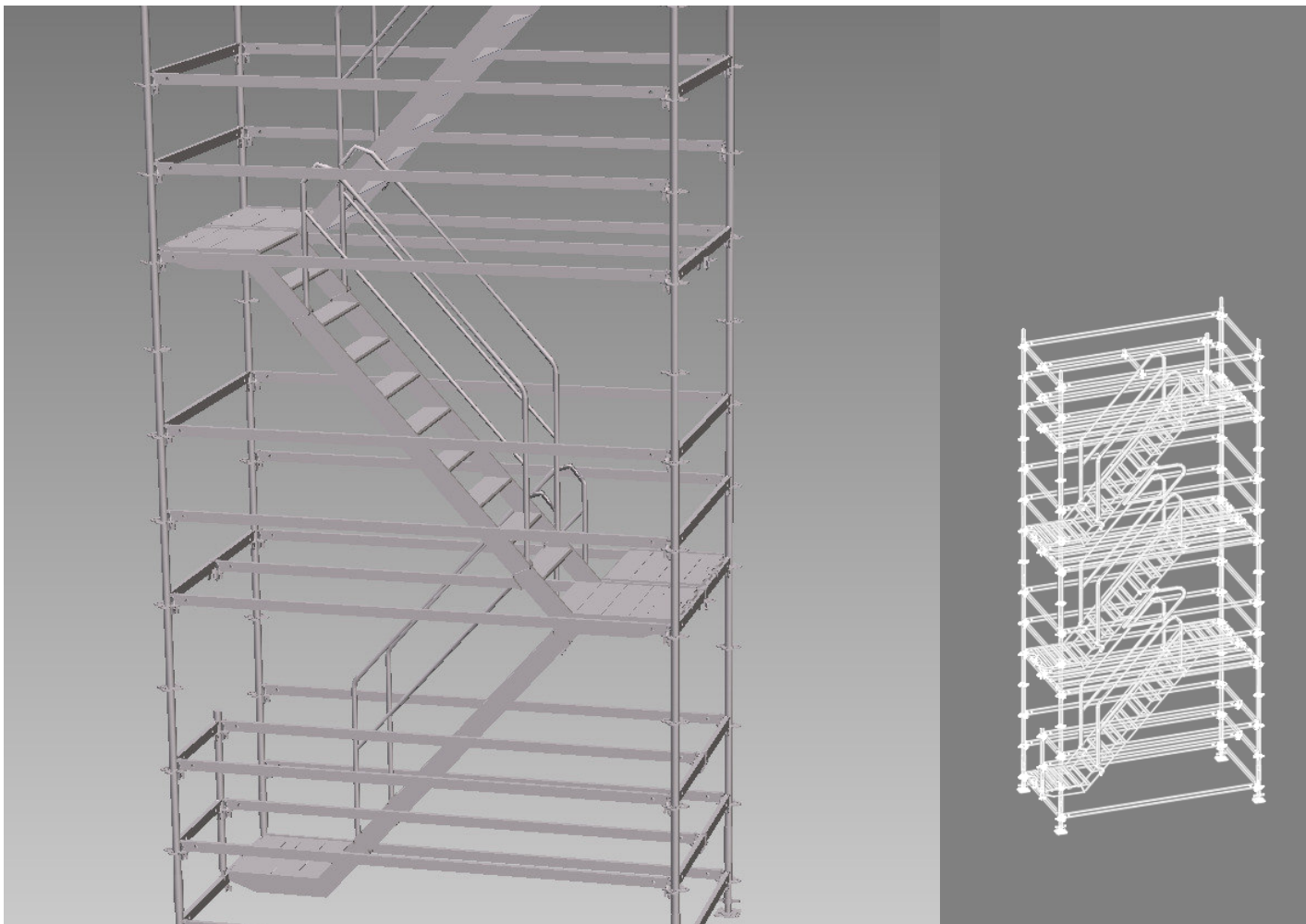

Amendment Log		
Version	Details	Issue Date
0	First Issue	Jan. 2019

	Page
Overview	1
Introduction	3
Safety considerations	4
Part A – Alternating	
Assembling and Dismantling	
A1 Assembling the base	5
A2 Assembling the first level	7
A3 Assembling additional levels	10
A4 Assembling the top level	12
A5 Safe storage of temporary Decks	14
A6 Anchoring	15
A7 Dismantling	16
Application	
A8 Base reactions	19
Part B – In Line	
Assembling and Dismantling	
B1 Assembling the base	21
B2 Assembling the first level	23
B3 Assembling additional levels	26
B4 Assembling the top level	28
B5 Anchoring	30
B6 Dismantling	31
Application	
B7 Base reactions	

Key

Pictogram | Definition



Safety Instructions



Note



Visual check



Tip

Dimensional specifications

Dimensions are specified in mm. Other units of measurement (cm) are used in product descriptions.

Conventions

- Instructions are numbered in sequence: 1. 2. 3. etc.
- Components are labelled with numbers corresponding to the overview drawing and are referenced within the text in brackets thus (1).
- Multiple component numbers indicating alternatives are represented with a slash: 1 / 2 etc.

Arrows

➡ Arrows represent an action

Presentational reference:

The illustrations on the front cover of these instructions are intended to be system representations only. The assembly steps presented are examples using the illustrated component sizes. They are also valid for alternative component sizes.

Alternating

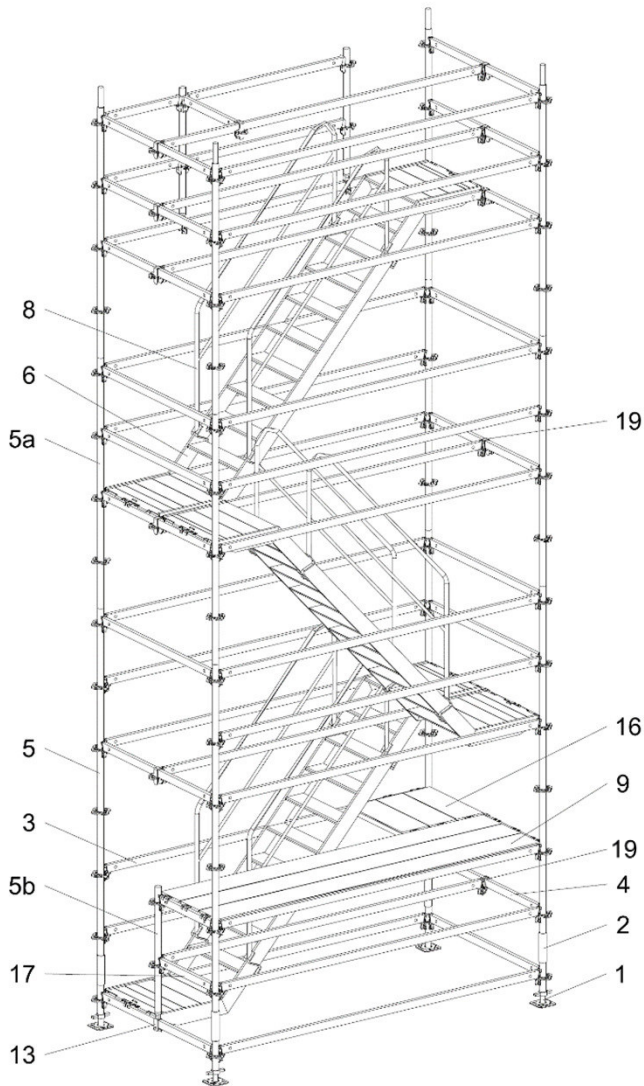

In Line

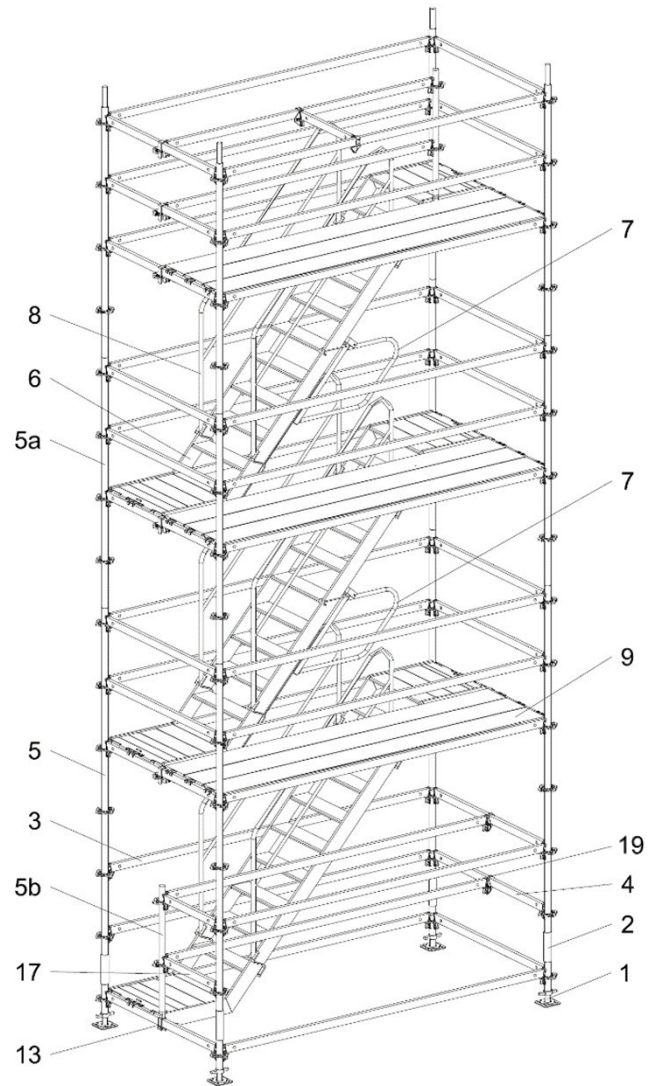

Components illustrated:

1. Adjustable Base Plate UJB
2. Base Standard UVB 24
3. Ledger UH 300, UH 300 Plus*
4. Ledger UH 150, UH 150 Plus*
5. Standard UVR 300
- 5a. Standard UVR 200
- 5b. Standard UVH 100
6. Staircase UAS 75 x 300/200
7. Stair Guardrail UAH
8. Stair Guardrail UAG
9. Steel Deck UDG 25 x 300**
10. Anchoring levels

Components shown later:

11. Spindle Locking UJS
12. Locking Pin ø 48/57
13. Spigot UH.
14. Ledger UH 250
15. Steel Deck UDG 25 x 150**
16. Steel Deck UDG 25 x 75**
17. Ledger UH 75
18. Ledger to Ledger Coupler UHA
19. Ledger to Ledger Coupler UHA Half***
20. Ledger to Ledger Coupler UHA Half w. Spigot

*Ledger UH may be replaced by Ledger UH Plus

**Steel Deck UDG may be replaced by Industrial Deck UDI

***UHA Half may be replaced by UHA (18)

Intended use

Product description

These Instructions for Assembly and Dismantling are supplementary to the PERI UP Flex Stairs 75 Instructions for Assembly and Use – Standard Configuration. All notes and data contained therein remain valid.

They describe the configuration for stair towers with the staircase units in the same direction and stair towers with alternating staircase units as a means of access for temporary work to be carried out on working areas situated above ground level.

The assembly and dismantling sequences describe a short-lift system of work in compliance with NASC SG4:15 Preventing Falls in Scaffolding Operations.

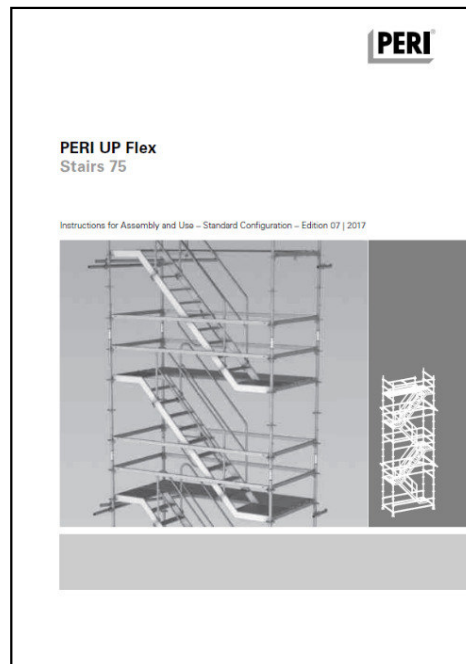

Presentational reference

The illustrations indicate the sequences for one bay size option. They are valid for both 2.5m and 3.0m bay options.

Components highlighted in red indicate temporary installed components removed before completion of the tower.

Personal Protection

Ensure persons are clipped to suitable anchor point before moving on and off temporary platforms.



For the scaffolds in this manual, safe connection points are:

- Any Rosette within a completed scaffold lift.
- Any Rosette up to 1m above a top platform level.
- Any Ledger connected between two uprights within a completed scaffold lift.
- Any Ledger connected between two uprights up to 1m above a top platform level.

Inspecting the anchoring

All anchor connections to the supporting structure should be tested in accordance with NASC TG4:17 Anchoring Systems for Scaffolding.

A1 Assembling the base

Erecting the scaffold must follow the sequence described below!

A1.1 Load distributing base area

Always begin erecting at the highest point, preferably at an internal corner.



Settlement must be avoided! The scaffold must only be erected on suitable distribution plates on ground or structure capable of withstanding all imposed loads!

Lay the Ledgers UH 300 (3) and Ledgers UH 150 (4) down to determine the length of the surface to be scaffolded. This will fix the distance between the Adjustable Base Plates UJB (1)

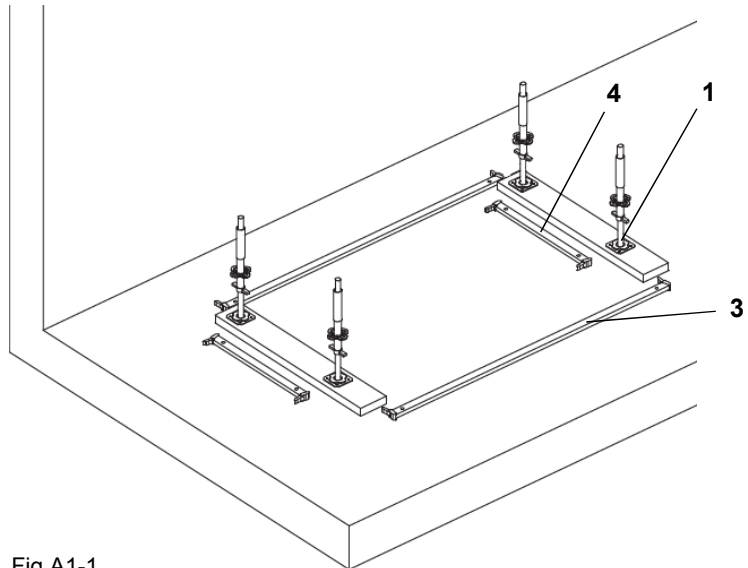

Fig.A1-1

A1.2 Adjustable Base Plates UJB

Position Adjustable Base Plates (1) at the ends of the Ledgers UH 300 Plus (3) & Ledgers UH 150 (4).



Adjustable Base Plates UJB 38-50/30 with red handles have a maximum extension of 355mm to top of collar handle. Adjustable Base Plates UJB 38-80/55 with yellow handles have a maximum extension of 595 mm. to top of collar handle. Check with PERI for suitability of use.



Base Spindles TR 38-70/50, without coloured handles, may be used instead of Adjustable Base Plates UJB (1). Extension range = 47mm – 535mm to top of collar handle.

A1.3 Changes in base level

Steps, slopes and changes in level can be accommodated using adjustment of the Adjustable Base Plates / Base Spindles.

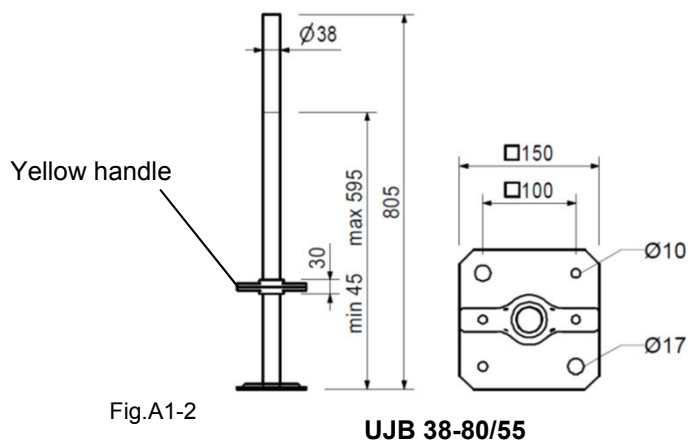

Fig.A1-2

UJB 38-80/55

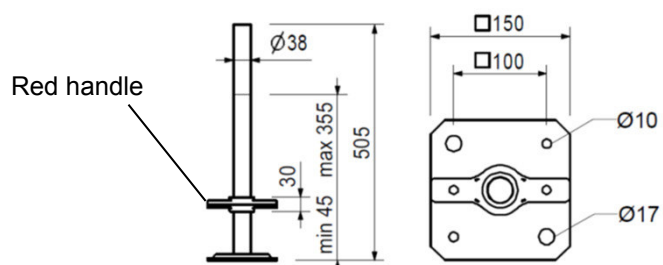

Fig.A1-3

UJB 38-50/30

A1 Assembling the base

A1.4 Base Standard UVB

Place Base Standards UVB 24 (2) over the Adjustable Base Plates UJB (1) and position at the required distance from the wall. Ensure all UVB Ø11 holes are aligned in same direction.

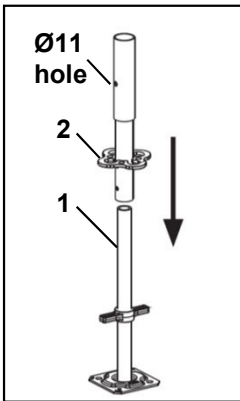

Fig.A1-4

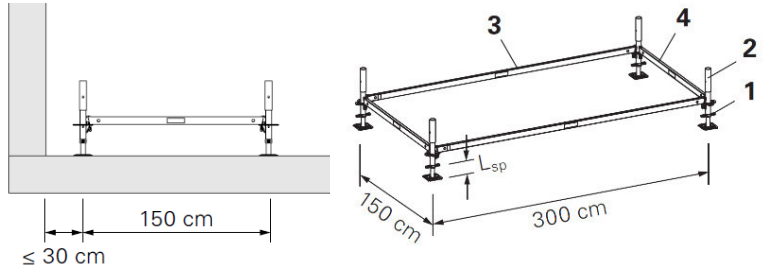

Fig.A1-5

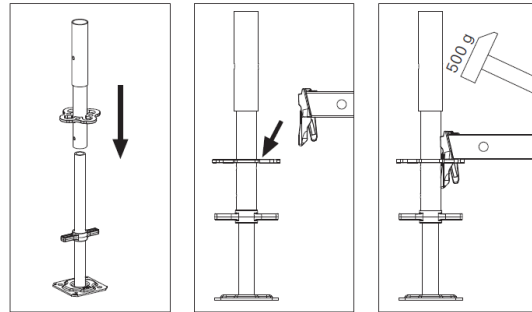

Fig.A1-6

A1.5 Ledger UH

Form a base frame by connecting the Base Standard UVB 24 (2) longitudinally with the Ledger UH 300 (3) and transversely with the Ledger UH 150 (4).

Ensure all Ledgers UH are level by adjusting the Adjustable Base Plates (1).

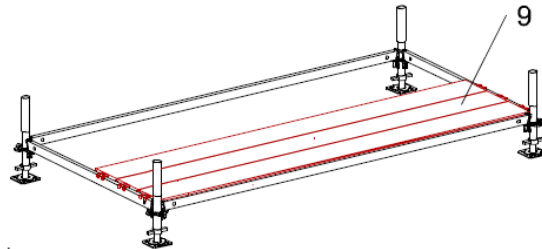

Fig.A1-7

Place Steel Decks UDG (9) on the Ledgers UH 150 (3) as an assembly aid to check squareness.

Do not secure Ledger wedges at this stage



The decks used at the base are an aid to erection only, they may be removed later.

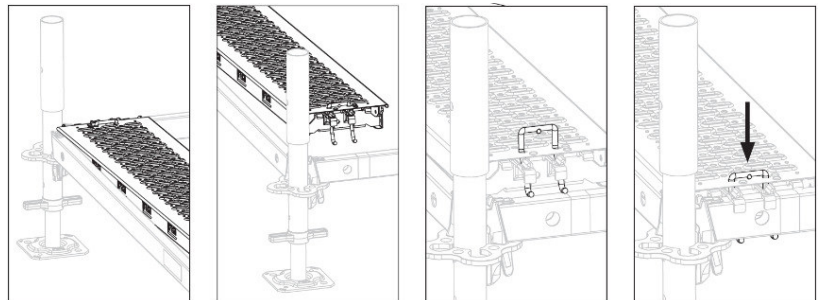

Fig.A1-8

A2.1 Vertical Standards UVR

PERI recommend using UVR 300 (5) at the first level.

Other combinations of standards (e.g. UVR 200 inside with UVR 300 outside) are structurally acceptable, but the customer must ensure safe method of erection & striking.

Insert Vertical Standards UVR (5) into the Base Standards UVB (2) ensuring alignment of the $\varnothing 11$ holes.

Place Spigot UH (13) on lower Ledger UH 150 (4).

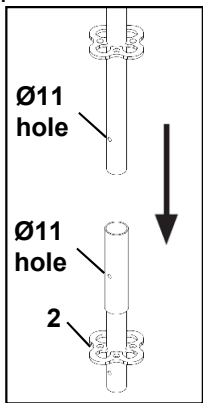

Fig.A2-1

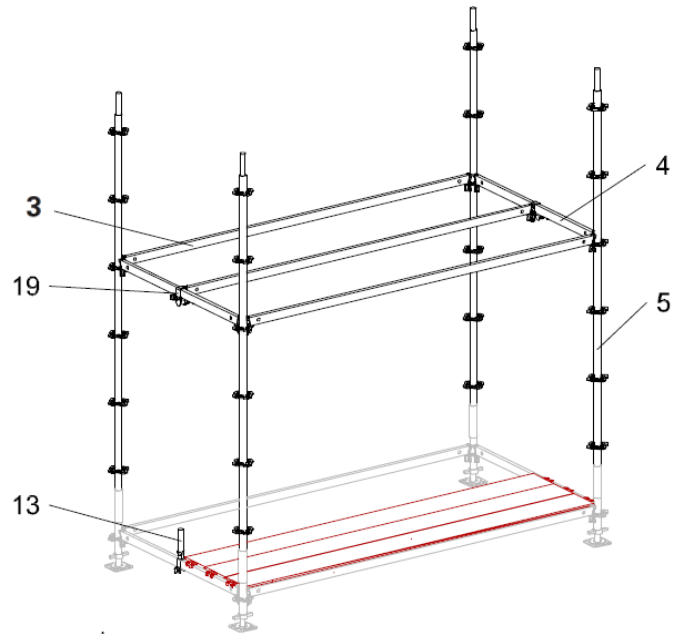

Fig.A2-2

A2.2 Ledgers UH

Attach UH Ledgers (3 / 4) to the Rosett on the Vertical Standards UVR (5), then securely fix all wedges at UVB level using a 500g hammer.

Attach the internal Ledger UH 300 (3), connected to the end Ledgers UH 150 (4) with Ledger to Ledger Coupler UHA Half (19).

Do not secure wedges at UVR level at this stage.

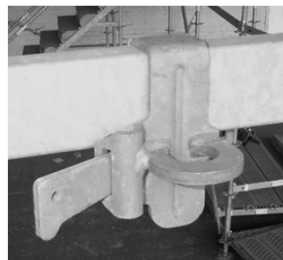

Fig.A2-3

A2.3 Staircase and guardrails

Place Staircase UAS (6) on Ledgers 150 (4). Securing hooks open and close when the unit is lowered on to the Ledgers UH 150 (4).



Securing hooks must be flush with the Deck after fitting.

Mount Stair Guardrails UAG (8) in the position shown (Fig A2-4.b)

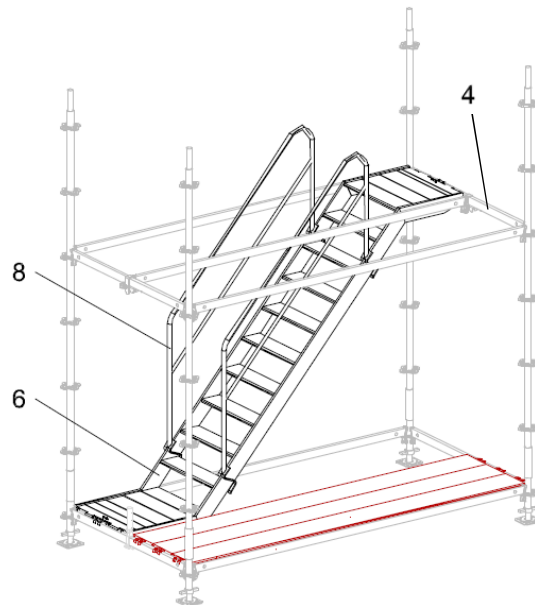

Fig.A2-4

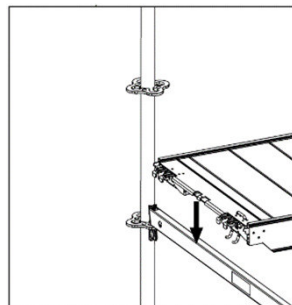

Fig.A2-4a

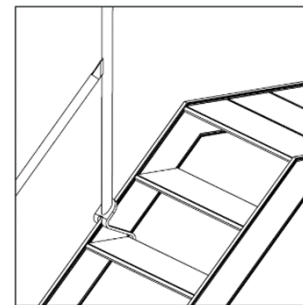

Fig.A2-4b

A2.4 Base lift guardrails

Attach Ledgers UH 300 (3) and UH 150 (4).

Insert Vertical Standard UVH 100 (5b) into the Spigot UH (13)

Attach the internal Ledger UH 300 (3), connected to the end Ledgers UH 150 (4) with Ledger to Ledger Coupler UHA Half (19) and to the Rosett of the Standard UVH 100 (5b)

Attach Ledgers UH 75 (17) to the uprights at the open end

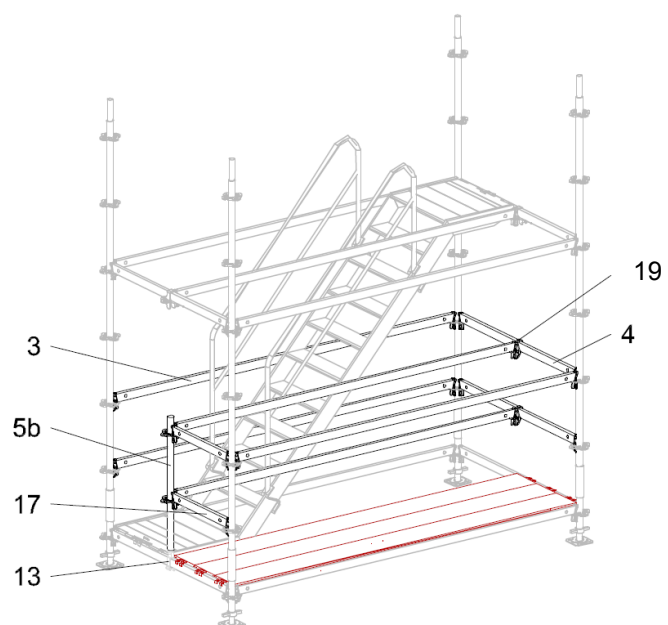

Fig.A2-5

A2.5 Guardrails

Reposition Steel Decks UDG 300 (9) to position shown.

From this platform level attach external Ledgers UH 300 (3) and Ledgers UH 150 (4) to the Vertical Standards UVR (5).

Attach the temporary internal Ledger UH 300 (3), connected to the end Ledgers UH 150 (4) with Ledger to Ledger Coupler UHA Half (19).

Attach the temporary internal Ledger UH 75 (17), connected to the Ledgers UH 300 (3) with Ledger to Ledger Coupler UHA Half (19)

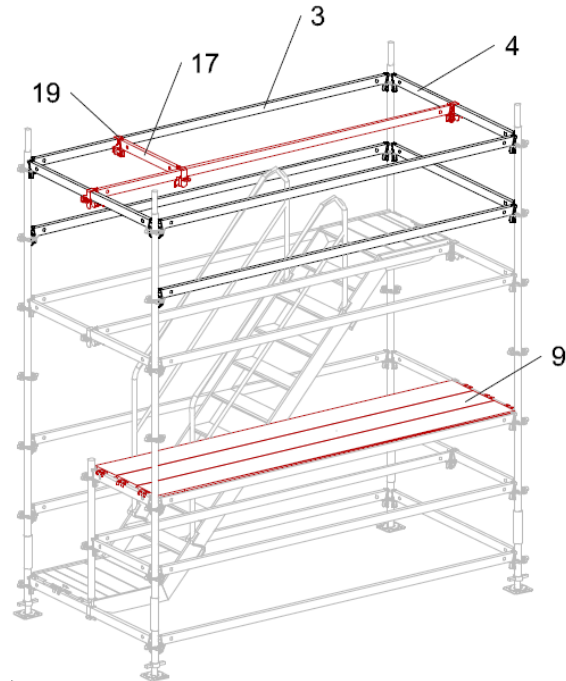

Fig.A2-6

A2.6 Temporary Platform

Attach Steel Decks UDG 75 (16) to create a temporary platform.

Securely fix all wedges at UVR level using a 500g hammer

First lift completed.

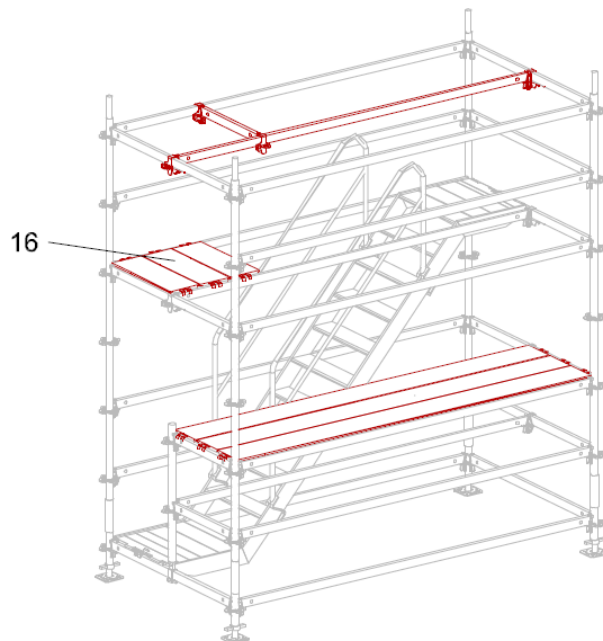

Fig.A2-7

A3 Assembling additional levels

All additional levels, except for the top level repeat the following steps.

A3.1 Vertical Standards UVR

PERI recommend using UVR 200 (5a) at the additional levels.

Other combinations of standards (e.g. UVR 200 inside with UVR 300 outside) are structurally acceptable, but the customer must ensure safe method of erection & striking.

Insert Vertical Standards UVR 200 (5a) into the inner lower Standards UVR ensuring alignment of the Ø11 holes

A3.2 Ledgers UH

Attach external Ledgers UH 300 (3) and Ledgers UH 150 (4) to the Vertical Standards UVR (5a).

Attach the internal Ledger UH 300 (3), connected to the end Ledgers UH 150 (4) with Ledger to Ledger Coupler UHA Half (19). (Fig A3-1)

Do not secure wedges at UVR level at this stage.

A3.3 Staircase and guardrails

Place Staircase UAS (6) on Ledgers 150 (4). Securing hooks open and close when the unit is lowered on to the Ledgers UH 150 (4).



Securing hooks must be flush with the Deck after fitting.

Mount Stair Guardrails UAG (8) in the position shown (Fig A3-2a)

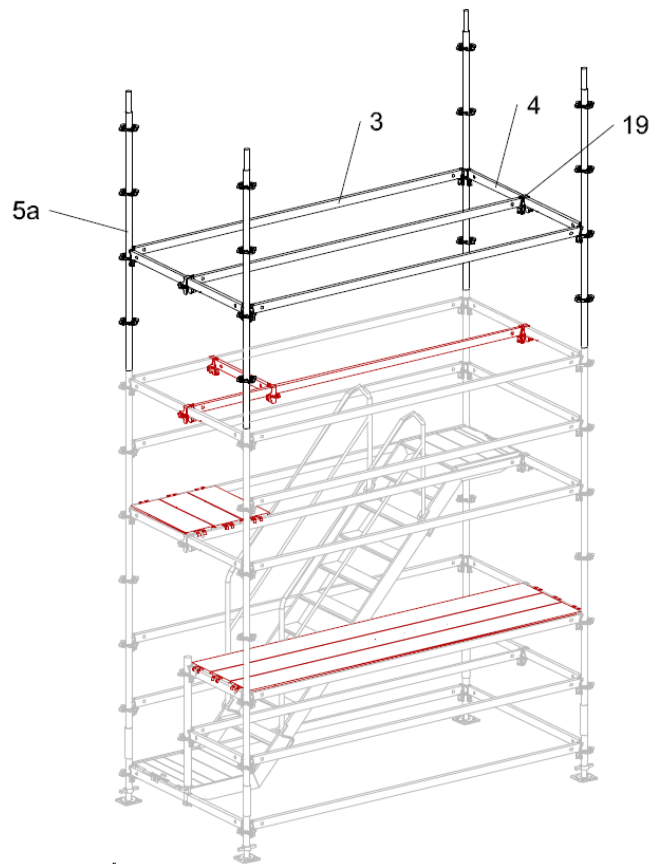

Fig.A3-1

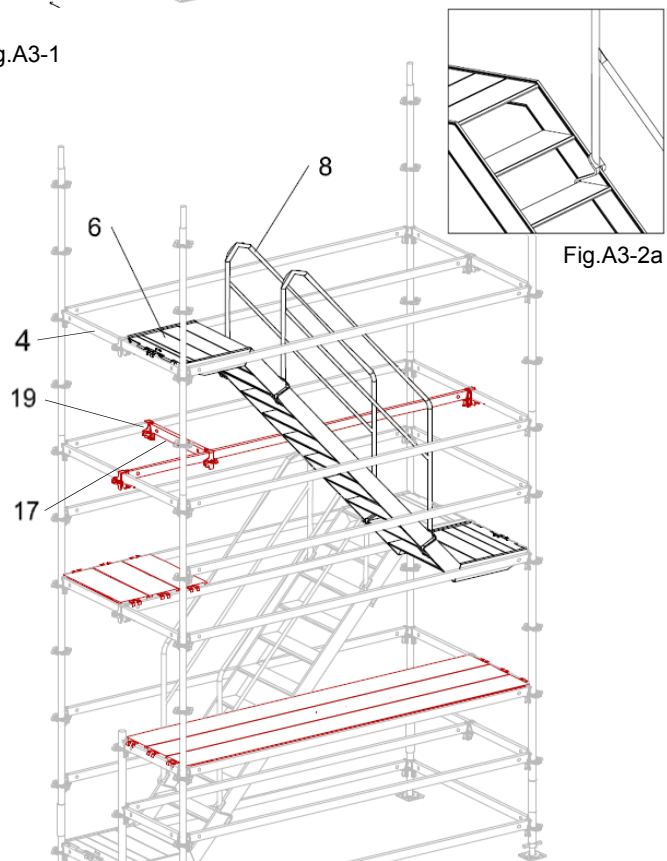

Fig.A3-2

A3.4 Guardrails

Remove the temporary Ledger UH 75 (17), and Ledger to Ledger Coupler UHA Half (19), indicated in Fig. A3-2.

Reposition Steel Decks UDG 300 (9) to position shown.

From this platform level attach external Ledgers UH 300 (3) and Ledgers UH 150 (4) to the Vertical Standards UVR (5a).

Attach the temporary internal Ledger UH 300 (3), connected to the end Ledgers UH 150 (4) with Ledger to Ledger Coupler UHA Half (19).

Attach the temporary internal Ledger UH 75 (17), connected to the Ledgers UH 300 (3) with Ledger to Ledger Coupler UHA Half (19)

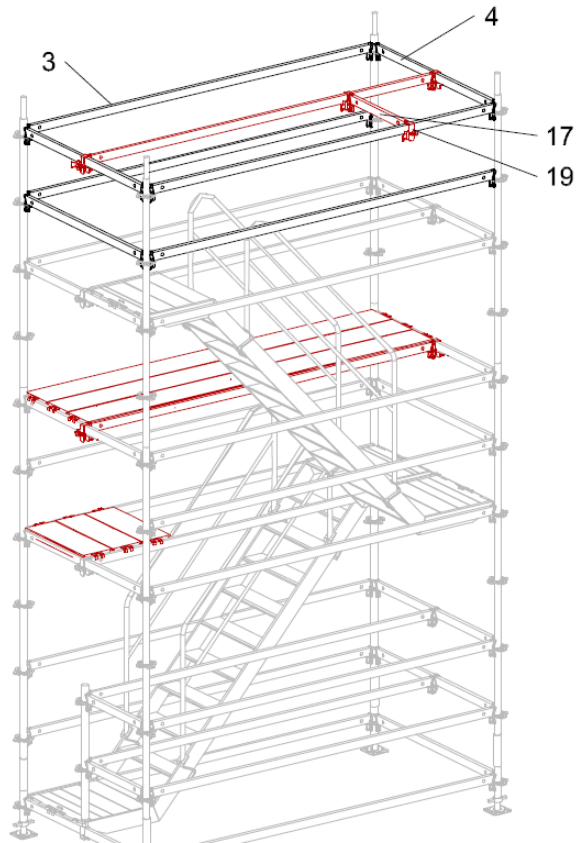

Fig.A3-4

A3-5 Temporary Platform

Attach Steel Decks UDG 75 (16) to create a temporary platform.

Securely fix all wedges at UVR level using a 500g hammer

Additional lift completed.

Repeat steps as required according to tower height.

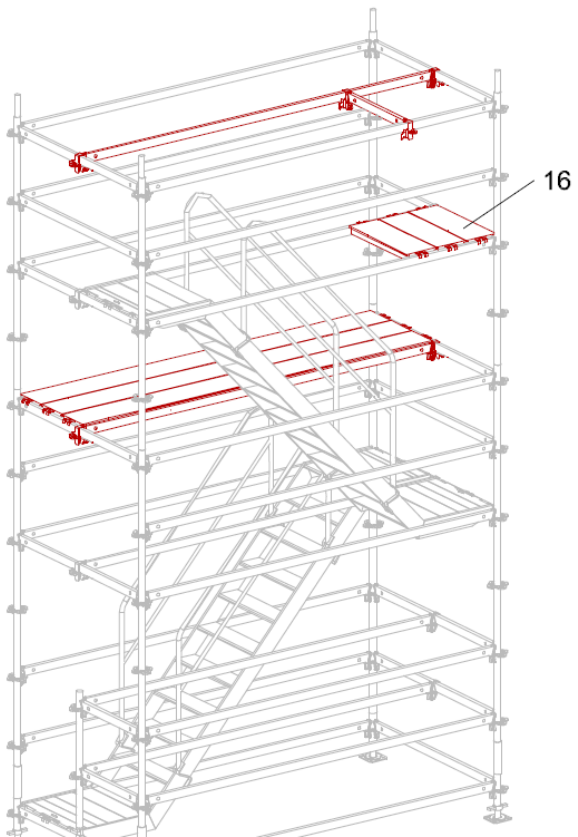

Fig.A3-5

A4 Assembling the top level

A4.1 Vertical Standards UVR

PERI recommend using UVR 200 (5a) at the top level.

Insert Vertical Standards UVR 200 (5a) into the inner lower Standards UVR ensuring alignment of the Ø11 holes

A4.2 Ledgers UH

Attach external Ledgers UH 300 (3) and Ledgers UH 150 (4) to the Vertical Standards UVR 200 (5a).

Attach the internal Ledger UH 300 (3), connected to the end Ledgers UH 150 (4) with Ledger to Ledger Coupler UHA Half (19).

Do not secure wedges at UVR level at this stage.

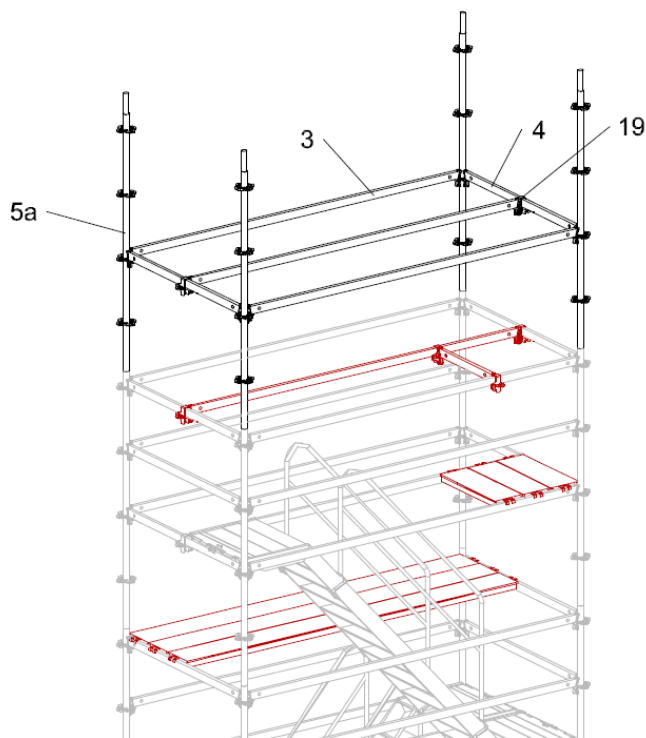

Fig.A4-1

A4.3 Staircase and guardrails

Place Staircase UAS (6) on Ledgers 150 (4). Securing hooks open and close when the unit is lowered on to the Ledgers UH 150 (4).



Securing hooks must be flush with the Deck after fitting.

Mount Stair Guardrails UAG (8) in the position shown (Fig A4-2a)

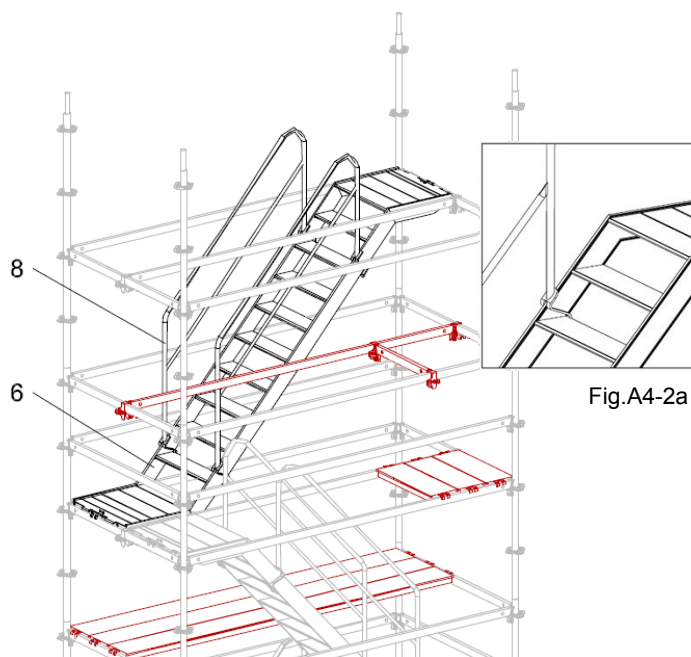

Fig.A4-2a

Fig.A4-2

A4.4 Guardrails

Remove the temporary Ledger UH 75 (17), and Ledger to Ledger Coupler UHA Half (19) indicated in Fig. A4-2.

Reposition Steel Decks UDG 300 (9) to position shown.

Place Spigot UH (13) on Ledger UH 300 (3).

Insert Vertical Standard UVH 100 (5b) into the Spigot UH (13)

Attach external Ledgers UH 300 (3), Ledgers UH 150 (4) and Ledgers UH 75 (17) to the Vertical Standards UVR 200 (5a) and UVH 100 (5b).

Attach the internal Ledger UH 300 (3), connected to the end Ledgers UH 150 (4) with Ledger to Ledger Coupler UHA Half (19).

Securely fix all wedges at UVR level using a 500g hammer.

Top lift completed.

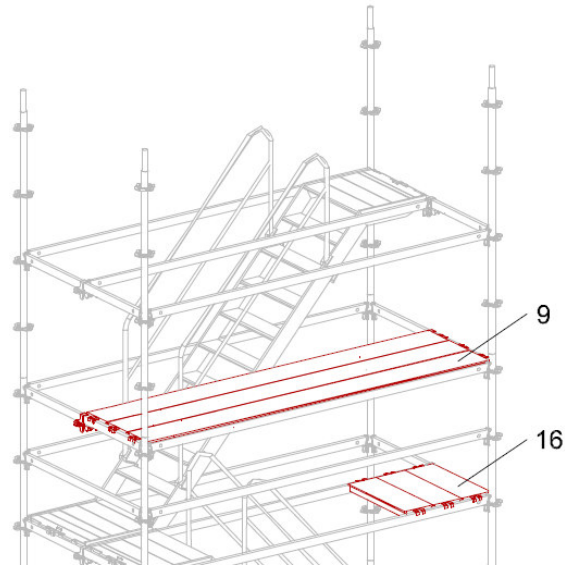

Fig.A4-3

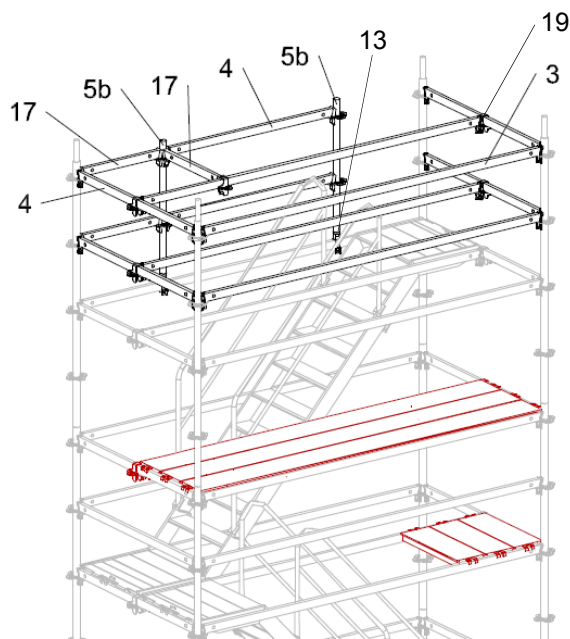

Fig.A4-4

A5.1 Steel Decks UDG

PERI recommend placing the temporary Steel Decks UDG 25 x 300 (9) and UDG 25 x 75 (16) at the base lift during use of the Stair Tower.

Decks are re-used during dismantling.

Tower completed.

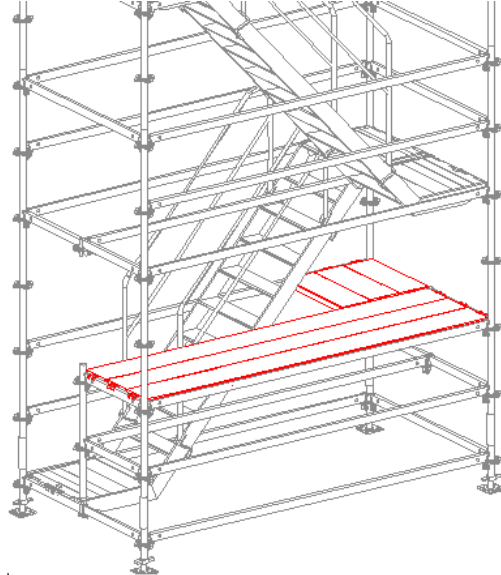

Fig.A5-1



Anchors are not designed to carry vertical loads!



- Anchors should be installed progressively along with the erection of the scaffolding.
- Fix with suitable fixings in accordance with NASC TG4:17.
- Insert the first row of anchors at a height of 3.0 m.
- Each anchor position consists of a short anchor and a triangulated anchor.

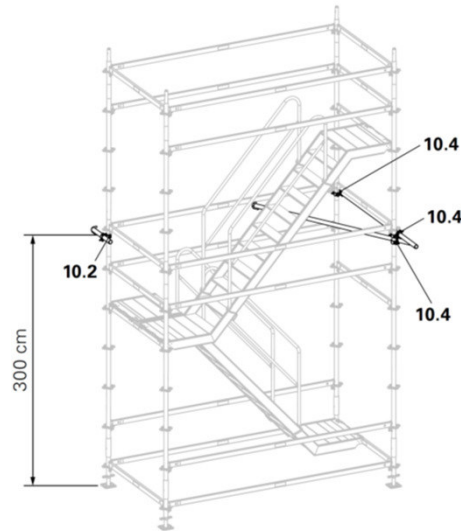

Fig.A6-1

A6.1 Short anchors

Fix Standard Coupler (10.2) with Wall Tie UWT 45 or short length of scaffold tube (10.1) to the inner leg.

Fix short anchor to the wall

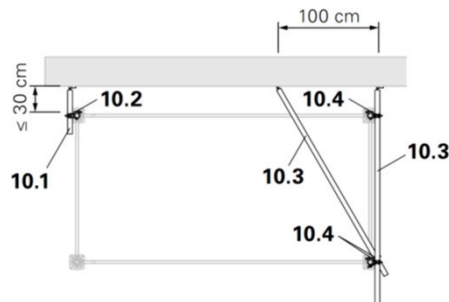

Fig.A6-2

A6.2 Triangulated anchors

Fix the first Wall Tie UWT 220 or scaffold tube (10.3) with standard couplers (10.4) to the inner and outer Standards UVR.

Fix the second Wall Tie UWT 220 or scaffold tube (10.3) with standard couplers (10.4) to the outer Standard UVR.

Fix Wall Ties or scaffold tubes to the wall.

Dismantle in reverse order from top to bottom as shown in the assembly procedure.

A7.1 Anchors

- Remove the anchors progressively with the staircase from top to bottom.
- In the event of work disruptions, the top level must not be extended more than 3.0m. beyond the last anchor position.

A7.2 Top Level

Attach the internal Ledger UH 300 (3), connected to the end Ledgers UH 150 (4) with Ledger to Ledger Coupler UHA Half (19).

Reposition Steel Decks UDG 300 (9) and UDG 75 (16) to position shown. (Fig. A7-1)

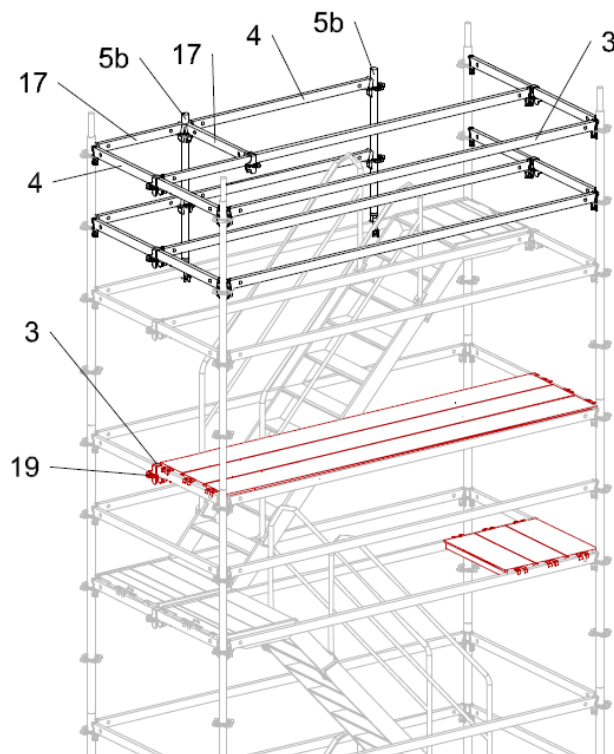

Fig.A7-1

Remove internal Ledger UH 75 (17) and external Ledgers UH 300 (3) with Ledger to Ledger Coupler UHA Half (19), Ledgers UH 150 (4), Ledgers UH 200 (21) and Ledger UH 75 (19) from the Vertical Standards UVR 200 (5b).

Remove both Vertical Standard UVH 100 (5b) with the Spigot UH (13).

Reposition Steel Decks UDG 300 (9) to position shown (Fig. A7-2)

Position Ledger UH 75 (17) with Ledger to Ledger Coupler UHA Half (19) as guardrail.

Remove Guardrails UAG (8) and Staircase UAS (6).

Remove Ledgers UH 300 (3), Ledgers UH 150 (4) and Ledger to Ledger Coupler UHA Half (19).

Finally remove Vertical Standards UVR 200 (5a).

Top lift removed

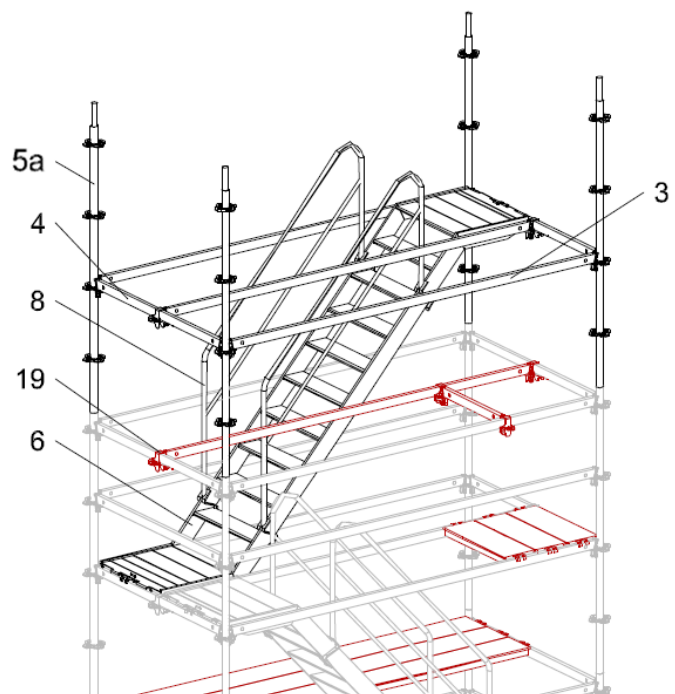

Fig.A7-2

A7.3 Intermediate level

All intermediate levels repeat the following steps.

Reposition Steel Decks UDG 75 (16) to position shown (Fig. A7-3).

Remove Ledgers UH 300 (3), Ledgers UH 150 (4), Ledger UH 75 (17) and Ledger to Ledger Coupler UHA Half (19).

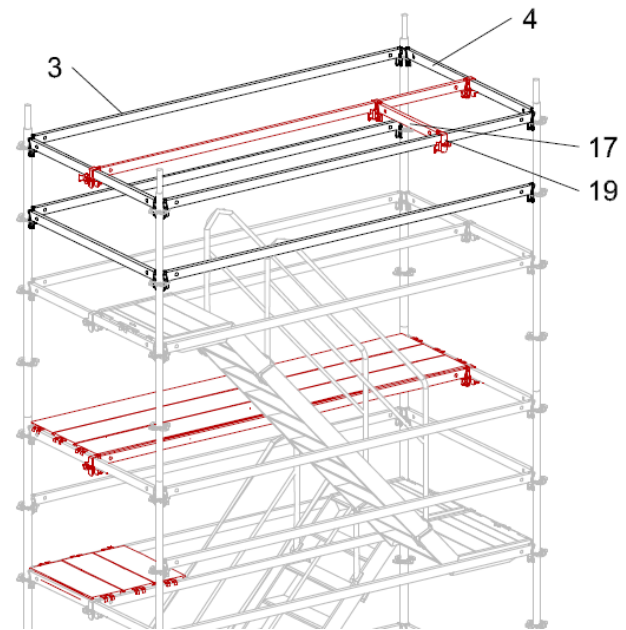

Fig.A7-3

Reposition Steel Decks UDG 300 (9) to position shown (Fig. A7-4)

Position Ledger UH 75 (17) with Ledger to Ledger Coupler UHA Half (19) as guardrail.

Remove Guardrails UAG (8) and Staircase UAS (6).

Remove Ledgers UH 300 (3), Ledgers UH 150 (4) and Ledger to Ledger Coupler UHA Half (19).

Finally remove Vertical Standards UVR 200 (5a).

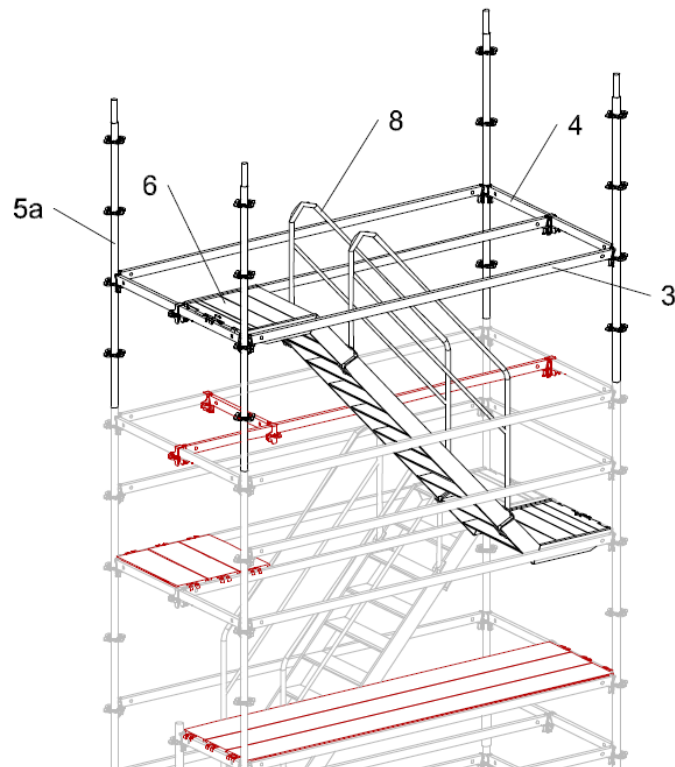

Fig.A7-4

Intermediate lift removed

Repeat steps as required according to tower height.

A7.4 Base level

Reposition Steel Decks UDG 300 (9) to position shown. (Fig.A7-5)

Remove the lower Ledgers UH 300 (3), Ledger to Ledger Coupler UHA Half (19), Ledgers UH 150 (4), Ledgers UH 75 (17), Standard UVH 100 (5b) and Spigot UH (13)

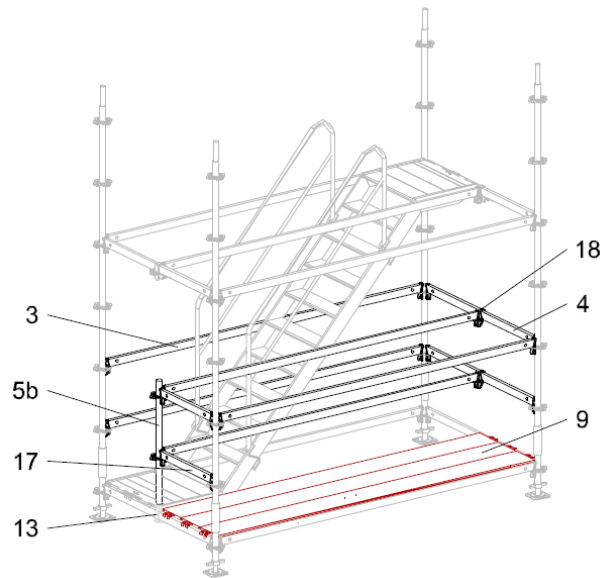

Fig.A7-5

Remove Staircase UAS (6) and UAG (8).

Remove Ledgers UH 300 (3), Ledgers UH 150 (4) and Ledger to Ledger Coupler UHA Half (19).

Finally remove Vertical Standards UVR 200 (5a).

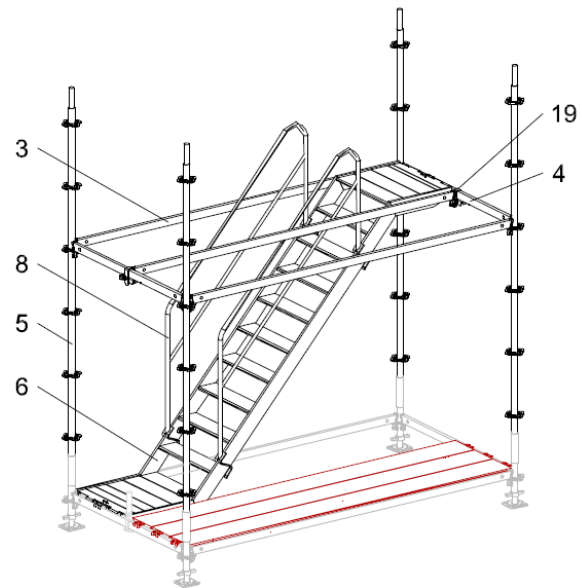

Fig.A7-6

From the ground, remove final base components

Dismantling completed

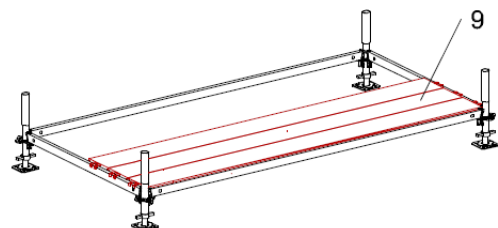

Fig.A7-7

A8.1 Reaction forces for legs

The reaction forces for the stair towers with alternating staircase units are given in Table 1 and are dependant on the height of the tower, bay length and applied live load.

Maximum leg loads allow for the total live load with a 75/25 distribution on plan.

The live load assumption for the stair tower leg loads indicated is 2kN/m² for a maximum of 20 linear metres. The equivalent number of persons indicated is based on an allowance of 100kg per person allowing for person self weight plus small tools in accordance with BS 5975.

PERI recommend that the user displays clear signage indicating the permissible limits for personnel numbers thus:

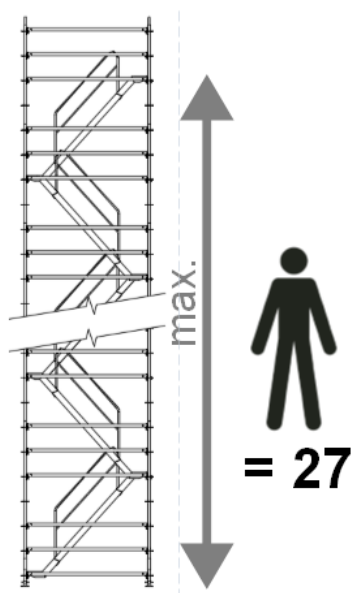

Fig.A8-1

Table 1	Bay Length = 2.5m		Bay Length = 3.0m	
	Tower height (m)	Max. Leg Load	Equiv. No. of persons:	Max. Leg Load
2.3	3.5	6	4.1	8
4.3	5.1	10	6.0	12
6.3	6.8	13	7.9	16
8.3	8.5	17	9.9	20
10.3	10.1	20	11.8	24
12.3	11.8	23	13.3	27
14.3	13.4	27	13.7	27
16.3	13.8	27	14.1	27
18.3	14.2	27	14.6	27
20.3	14.6	27	15.0	27
22.3	15.0	27	15.5	27
24.3	15.4	27	15.9	27
26.3	15.8	27	16.3	27
28.3	16.3	27	16.8	27
30.3	16.7	27	17.2	27
32.3	17.1	27	17.7	27
34.3	17.5	27	18.1	27
36.3	17.9	27	18.5	27
38.3	18.3	27	19.0	27
40.3	18.7	27	19.4	27
42.3	19.1	27	19.9	27
44.3	19.5	27	20.3	27
46.3	19.9	27	20.8	27
48.3	20.3	27	21.2	27
50.3	20.7	27	21.6	27
52.3	21.1	27	22.1	27
54.3	21.5	27	22.5	27
56.3	21.9	27	23.0	27
58.3	22.3	27	23.4	27
60.3	22.7	27	23.8	27
62.3	23.2	27	24.3	27
64.3	23.6	27	24.7	27
66.3	24.0	27	25.2	27

B1 Assembling the base

Erecting the scaffold must follow the sequence described below!

B1.1 Load distributing base area

Always begin erecting at the highest point, preferably at an internal corner.



Settlement must be avoided! The scaffold must only be erected on suitable distribution plates on ground or structure capable of withstanding all imposed loads!

Lay the Ledgers UH 300 (3) and Ledgers UH 150 (4) down to determine the length of the surface to be scaffolded. This will fix the distance between the Adjustable Base Plates UJB (1)

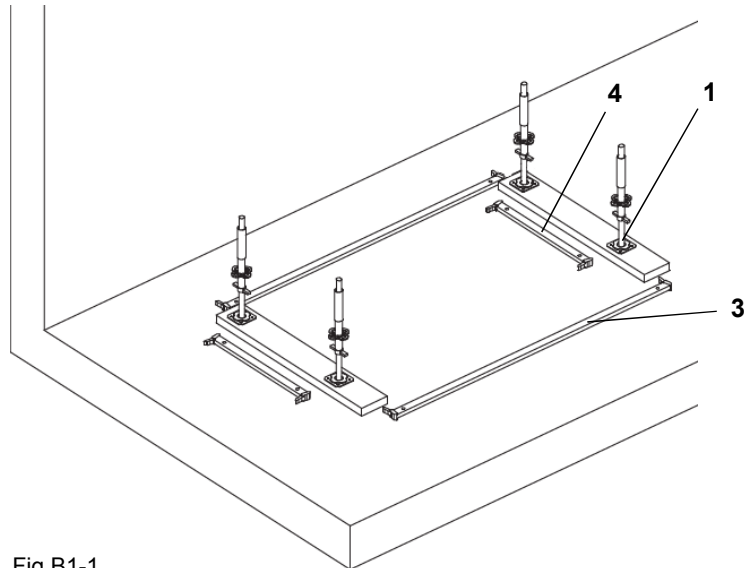

Fig.B1-1

B1.2 Adjustable Base Plates UJB

Position Adjustable Base Plates (1) at the ends of the Ledgers UH 300 Plus (3) & Ledgers UH 150 (4).



Adjustable Base Plates UJB 38-50/30 with red handles have a maximum extension of 355mm to top of collar handle. Adjustable Base Plates UJB 38-80/55 with yellow handles have a maximum extension of 595 mm. to top of collar handle. Check with PERI for suitability of use.



Base Spindles TR 38-70/50, without coloured handles, may be used instead of Adjustable Base Plates UJB (1). Extension range = 47mm – 535mm to top of collar handle.

B1.3 Changes in base level

Steps, slopes and changes in level can be accommodated using adjustment of the Adjustable Base Plates / Base Spindles.

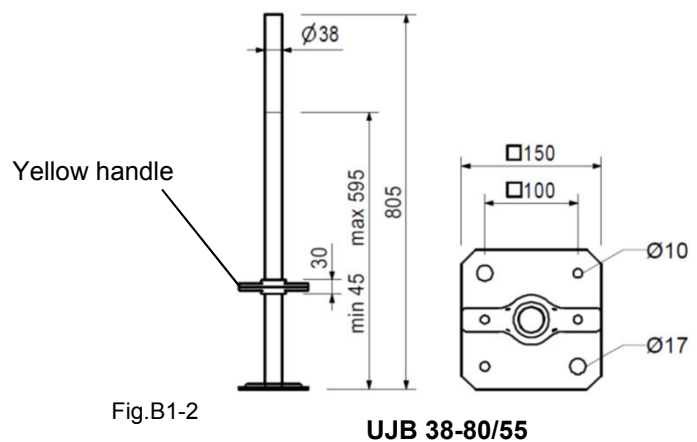

Fig.B1-2

UJB 38-80/55

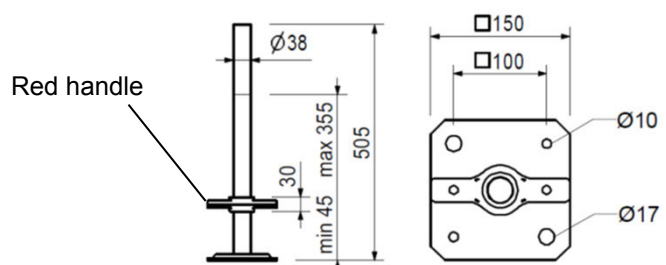

Fig.B1-3

UJB 38-50/30

B1 Assembling the base

B1.4 Base Standard UVB

Place Base Standards UVB 24 (2) over the Adjustable Base Plates UJB (1) and position at the required distance from the wall. Ensure all UVB Ø11 holes are aligned in same direction.

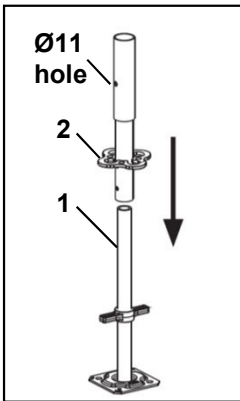

Fig.B1-4

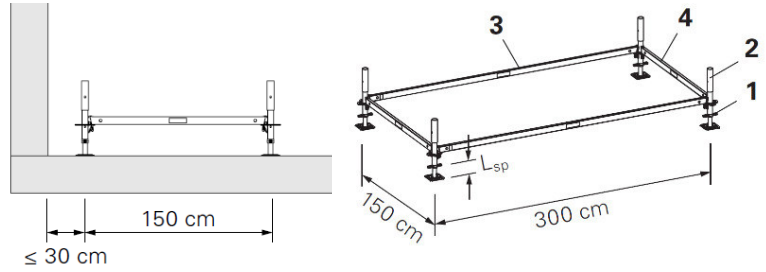

Fig.B1-5

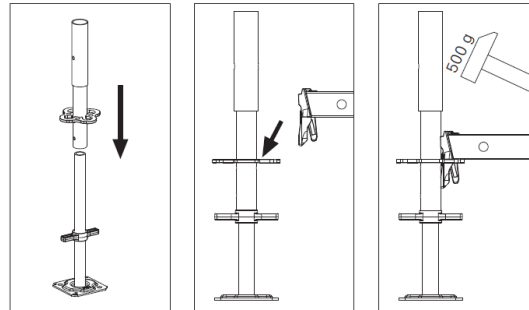

Fig.B1-6

B1.5 Ledger UH

Form a base frame by connecting the Base Standard UVB 24 (2) longitudinally with the Ledger UH 300 (3) and transversely with the Ledger UH 150 (4).

Ensure all Ledgers UH are level by adjusting the Adjustable Base Plates (1).

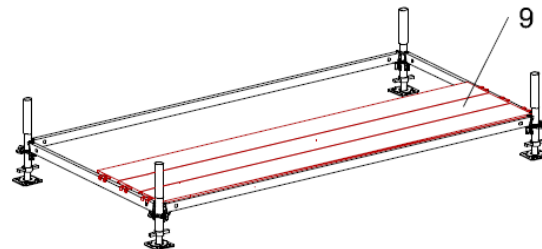

Fig.B1-7

Place Steel Decks UDG (9) on the Ledgers UH 150 (3) as an assembly aid to check squareness.

Do not secure Ledger wedges at this stage



The decks used at the base are an aid to erection only, they may be removed later.

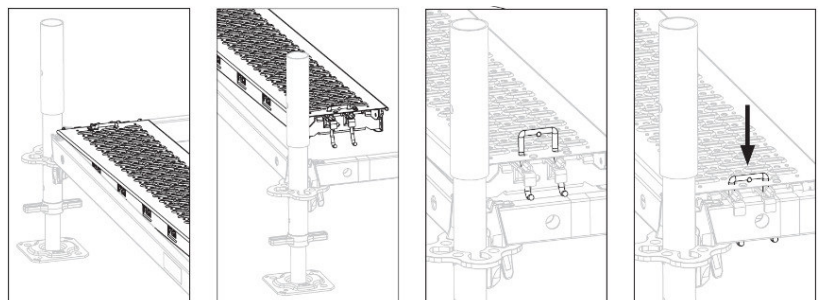

Fig.B1-8

B2.1 Vertical Standards UVR

PERI recommend using UVR 300 (5) at the first level.

Other combinations of standards (e.g. UVR 200 inside with UVR 300 outside) are structurally acceptable, but the customer must ensure safe method of erection & striking.

Insert Vertical Standards UVR (5) into the inner Base Standards UVB (2) ensuring alignment of the Ø11 holes.

Place Spigot UH (13) on lower Ledger UH 150 (4).

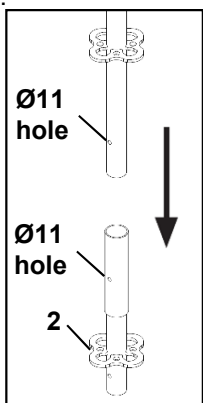

Fig.B 2-1

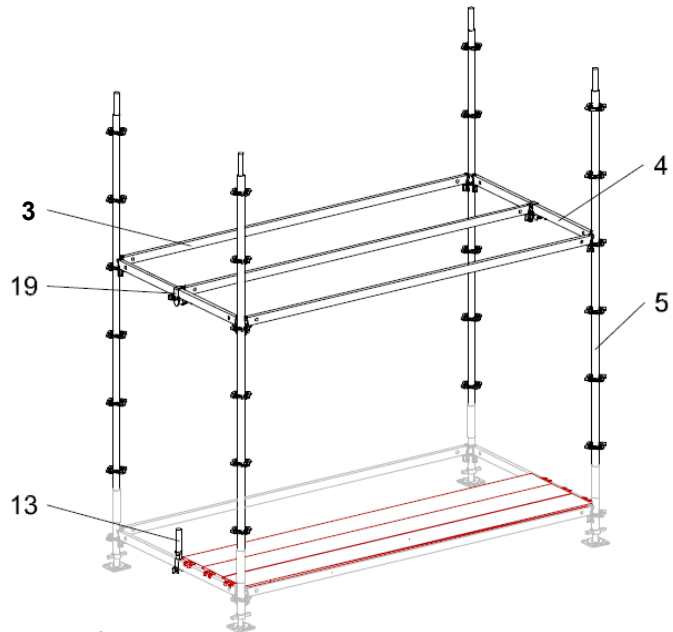

Fig.B2-2

B2.2 Ledgers UH

Attach UH Ledgers (3 / 4) to the Rosett on the Vertical Standards UVR (5), then securely fix all wedges at UVB level using a 500g hammer.

Attach the internal Ledger UH 300 (3), connected to the end Ledgers UH 150 (4) with Ledger to Ledger Coupler UHA Half (19).

Do not secure wedges at UVR level at this stage.

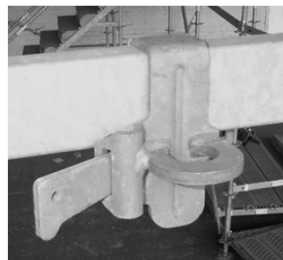

Fig.B2-3

B2.3 Staircase and guardrails

Place Staircase UAS (6) on Ledgers 150 (4). Securing hooks open and close when the unit is lowered on to the Ledgers UH 150 (4).



Securing hooks must be flush with the Deck after fitting.

Mount Stair Guardrails UAG (8) in the position shown (Fig B2-4.b)

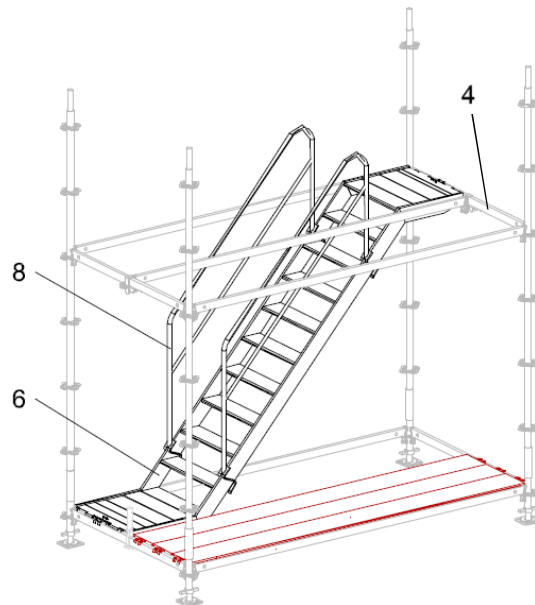

Fig.B2-4

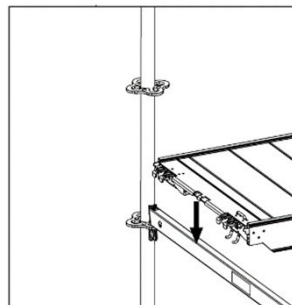

Fig.B2-4a

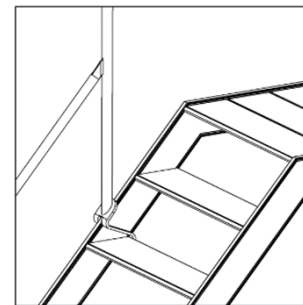

Fig.B2-4b

B2.4 Base lift guardrails

Attach Ledgers UH 300 (3) and UH 150 (4).

Insert Vertical Standard UVH 100 (5b) into the Spigot UH (13)

Attach the internal Ledger UH 300 (3), connected to the end Ledgers UH 150 (4) with Ledger to Ledger Coupler UHA Half (19) and to the Rosett of the Standard UVH 100 (5b)

Attach Ledgers UH 75 (17) to the uprights at the open end

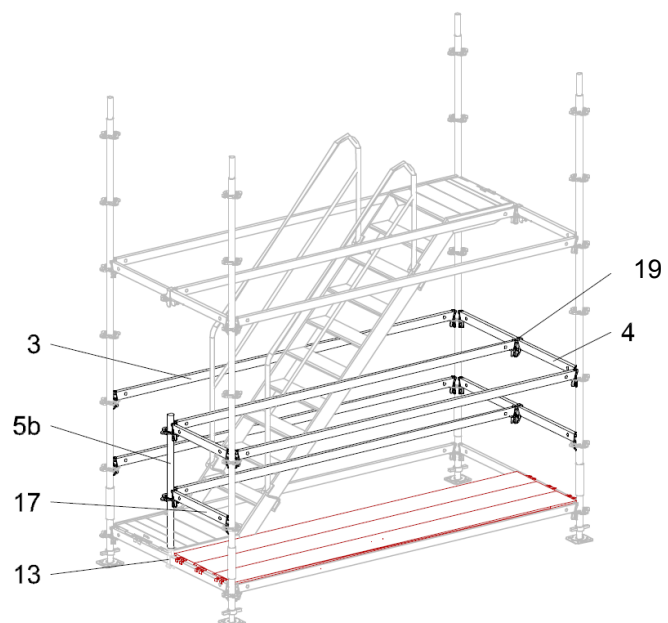

Fig.B2-5

B2.5 Guardrails

Reposition Steel Decks UDG 300 (9) to position shown.

From this platform level attach external Ledgers UH 300 (3) and Ledgers UH 150 (4) to the Vertical Standards UVR (5).

Attach the temporary internal Ledger UH 300 (3), connected to the end Ledgers UH 150 (4) with Ledger to Ledger Coupler UHA Half (19).

First lift completed.

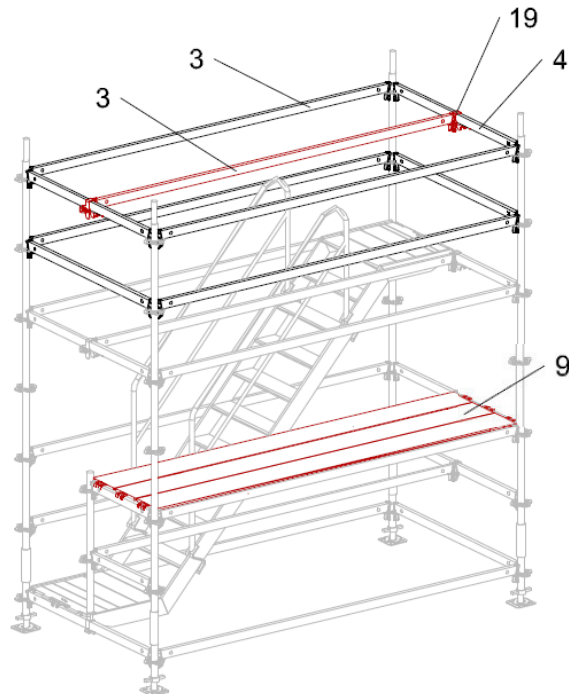

Fig.B2-6

B3 Assembling additional levels

All additional levels, except for the top level repeat the following steps.

B3.1 Vertical Standards UVR

PERI recommend using UVR 200 (5a) at the additional levels.

Other combinations of standards (e.g. UVR 200 inside with UVR 300 outside) are structurally acceptable, but the customer must ensure safe method of erection & striking.

Insert Vertical Standards UVR 200 (5a) into the inner lower Standards UVR ensuring alignment of the Ø11 holes

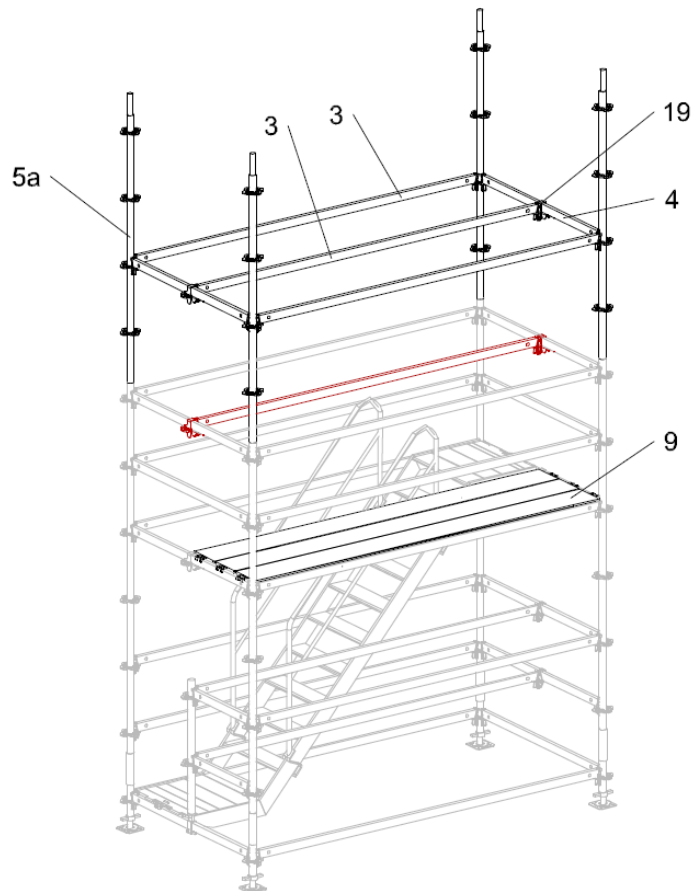

Fig.B3-1

B3.2 Ledgers UH

Attach external Ledgers UH 300 (3) and Ledgers UH 150 (4) to the Vertical Standards UVR (5a).

Attach the internal Ledger UH 300 (3), connected to the end Ledgers UH 150 (4) with Ledger to Ledger Coupler UHA Half (19). (Fig B3-1)

Do not secure wedges at UVR level at this stage.

B3.3 Staircase and guardrails

Place Staircase UAS (6) on Ledgers 150 (4). Securing hooks open and close when the unit is lowered on to the Ledgers UH 150 (4).



Securing hooks must be flush with the Deck after fitting.

Mount Stair Guardrails UAH (7) and UAG (8) in the position shown. (Fig B3-2a)

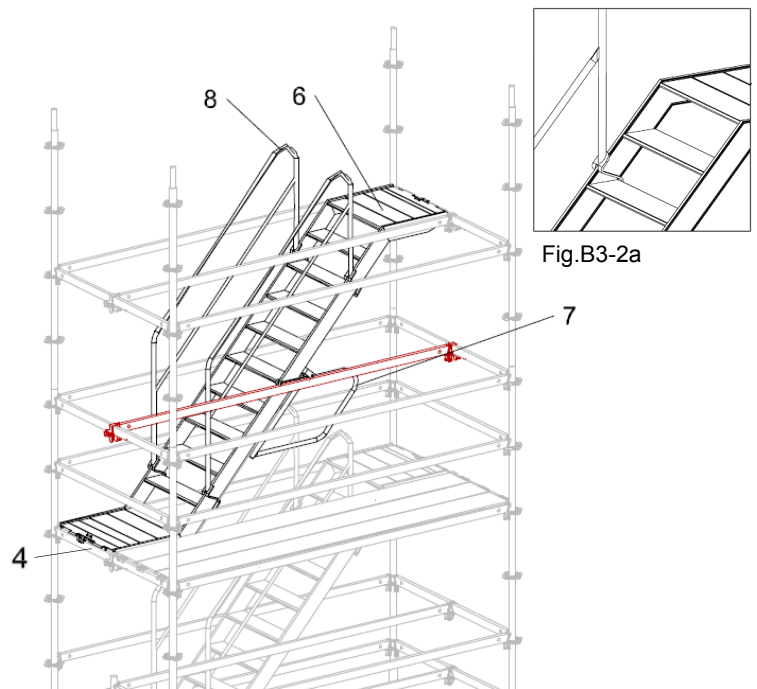

Fig.B3-2

B3.4 Guardrails

Reposition Steel Decks UDG 300 (9) to position shown.

From this platform level attach external Ledgers UH 300 (3) and Ledgers UH 150 (4) to the Vertical Standards UVR 200 (5a).

Attach the temporary internal Ledger UH 300 (3), connected to the end Ledgers UH 150 (4) with Ledger to Ledger Coupler UHA Half (19).

Additional lift completed.

Repeat steps as required according to tower height.

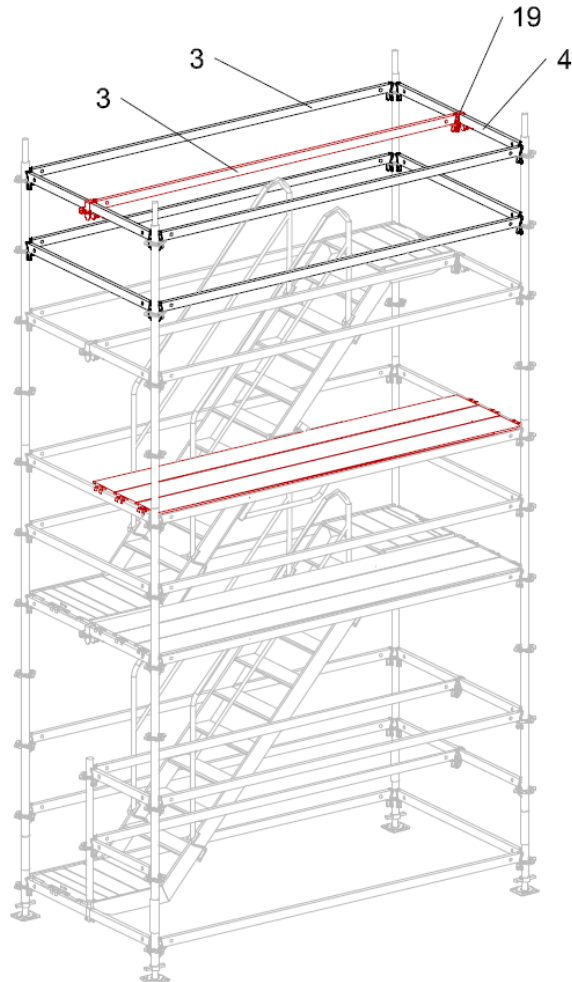

Fig.B3-3

B4 Assembling the top level

B4.1 Vertical Standards UVR

PERI recommend using UVR 200 (5a) at the top level.

Insert Vertical Standards UVR 200 (5a) into the inner lower Standards UVR ensuring alignment of the Ø11 holes

B4.2 Ledgers UH

Attach external Ledgers UH 300 (3) and Ledgers UH 150 (4) to the Vertical Standards UVR 200 (5a).

Attach the internal Ledger UH 300 (3), connected to the end Ledgers UH 150 (4) with Ledger to Ledger Coupler UHA Half (19).

Do not secure wedges at UVR level at this stage.

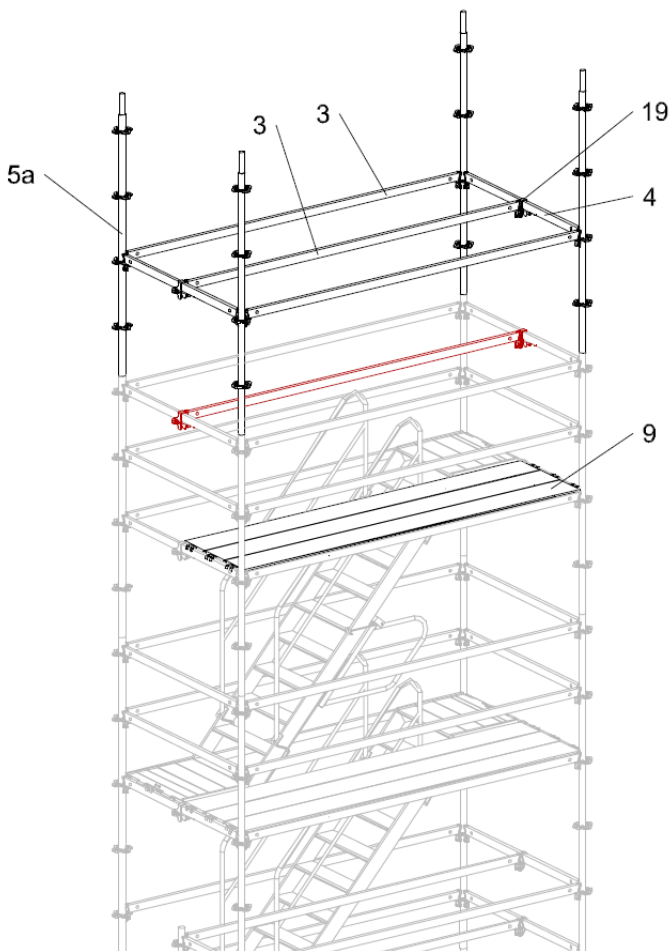

Fig.B4-1

B4.3 Staircase and guardrails

Place Staircase UAS (6) on Ledgers 150 (4). Securing hooks open and close when the unit is lowered on to the Ledgers UH 150 (4).



Securing hooks must be flush with the Deck after fitting.

Mount Stair Guardrails UAH (7) and UAG (8) in the position shown. (Fig B4-2a)

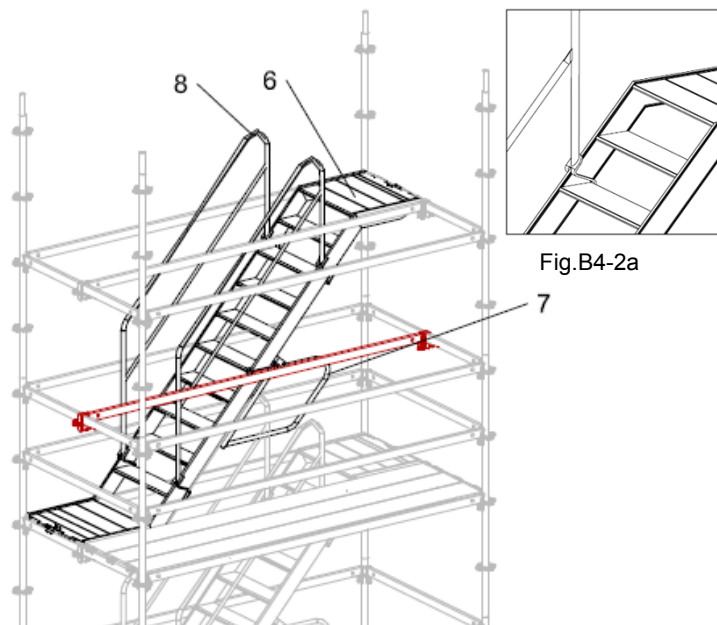

Fig.B4-2

B4 Assembling the top level

B4.4 Guardrails

Reposition Steel Decks UDG 300 (9) to position shown.

Place Spigot UH (13) on Ledger UH 300 (3).

Insert Vertical Standard UVH 100 (5b) into the Spigot UH (13)

Attach external Ledgers UH 300 (3), Ledgers UH 150 (4), Ledgers UH 250 (14) and Ledger UH 75 (19) to the Vertical Standards UVR 200 (5b).

Attach the internal Ledger UH 75 (17), connected to the external Ledger UH 300 (4) and Ledger UH 250 (14) with Ledger to Ledger Coupler UHA Half (19).

Securely fix all wedges at UVR level using a 500g hammer.

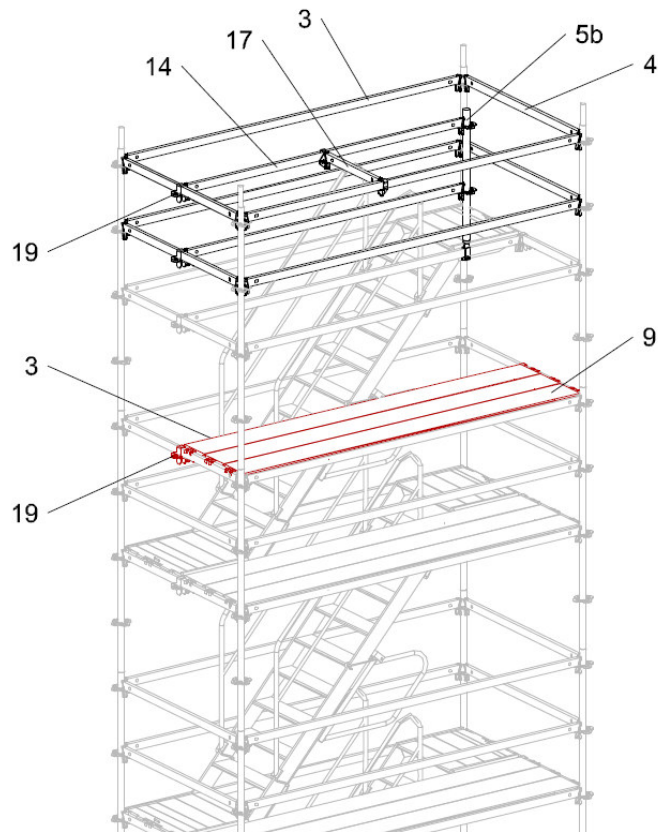

Fig.B4-3

B4.5 Decks

Finally reposition Steel Decks UDG 300 (9) to position shown.

Top lift completed.

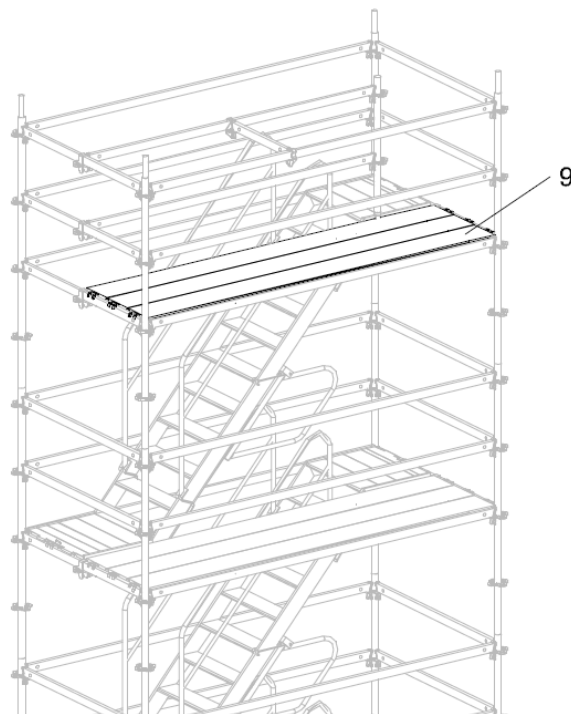

Fig.B4-4



Anchors are not designed to carry vertical loads!



- Anchors should be installed progressively along with the erection of the scaffolding.
- Fix with suitable fixings in accordance with NASC TG4:17.
- Insert the first row of anchors at a height of 4.0 m.
- Each anchor position consists of a short anchor and a triangulated anchor.

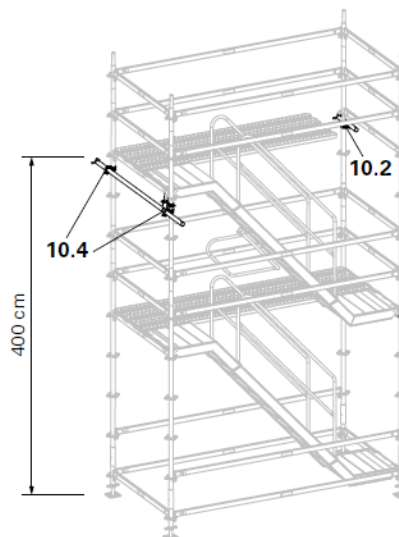

Fig.B5-1

B6.1 Short anchors

Fix Standard Coupler (10.2) with Wall Tie UWT 45 or short length of scaffold tube (10.1) to the inner leg.

Fix short anchor to the wall.

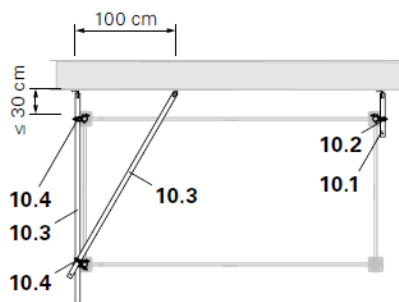

Fig.B5-2

B6.2 Triangulated anchors

Fix the first Wall Tie UWT 220 or scaffold tube (10.3) with standard couplers (10.4) to the inner and outer Standards UVR.

Fix the second Wall Tie UWT 220 or scaffold tube (10.3) with standard couplers (10.4) to the outer Standard UVR.

Fix Wall Ties or scaffold tubes to the wall.

Dismantle in reverse order from top to bottom as shown in the assembly procedure.

B6.1 Anchors

- Remove the anchors progressively with the staircase from top to bottom.
- In the event of work disruptions, the top level must not be extended more than 4.0m. beyond the last anchor position.

B6.2 Top Level

Attach the internal Ledger UH 300 (3), connected to the end Ledgers UH 150 (4) with Ledger to Ledger Coupler UHA Half (19).

Reposition Steel Decks UDG 300 (9) to position shown. (Fig. B6-1)

Remove Vertical Standard UVH 100 (5b) with the Spigot UH (13)

Remove internal Ledger UH 75 (17) and external Ledgers UH 300 (3) with Ledger to Ledger Coupler UHA Half (19), Ledgers UH 150 (4), Ledgers UH 200 (21) and Ledger UH 75 (19) from the Vertical Standards UVR 200 (5b).

Remove Staircase UAS (6), Stair Guardrails UAH (7) and UAG (8).

Remove temporary Steel Decks UDG 300 (9).

Remove Ledgers UH 300 (3), Ledgers UH 150 (4) and Ledger to Ledger Coupler UHA Half (19).

Finally remove Vertical Standards UVR 200 (5a).

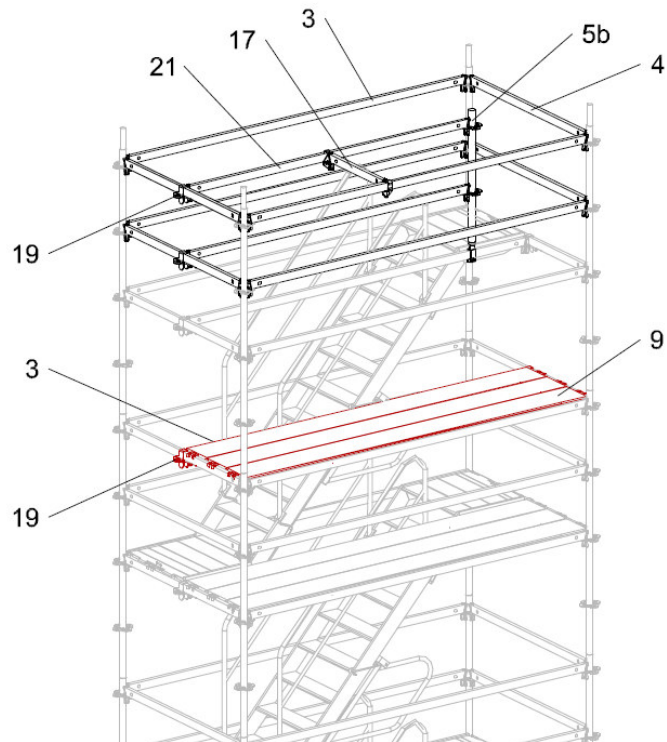

Fig.B6-1

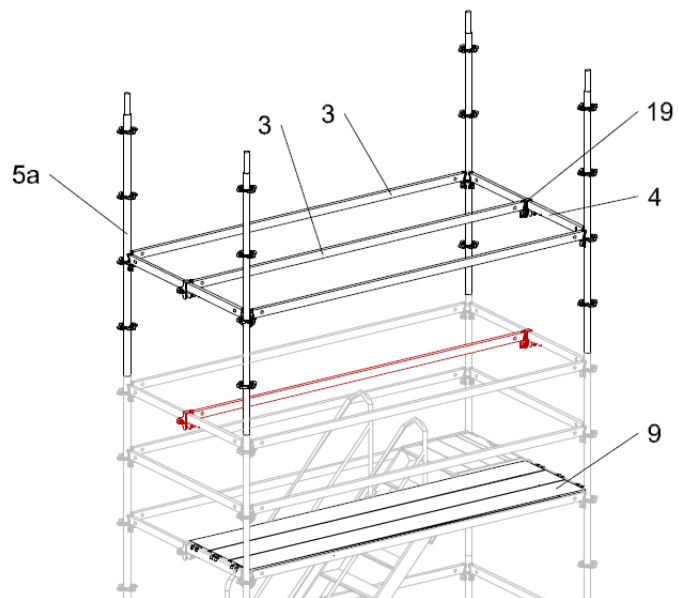

Fig.B6-2

Top lift removed

B6.3 Intermediate level

All intermediate levels repeat the following steps

Reposition Steel Decks UDG 300 (9) to position shown.

Remove Ledgers UH 300 (3), Ledgers UH 150 (4) and Ledger to Ledger Coupler UHA Half (19).

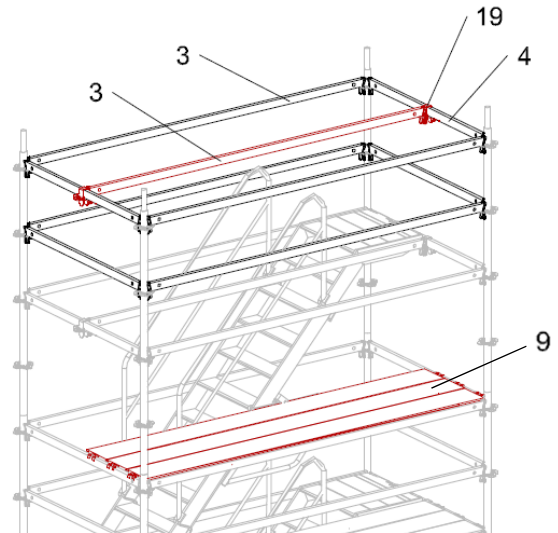

Fig.B6-3

Remove temporary Steel Decks UDG 300 (9).

Remove Vertical Standards UVR 200 (5a) and Ledgers UH 300 (3), Ledgers UH 150 (4) and Ledger to Ledger Coupler UHA Half (19).

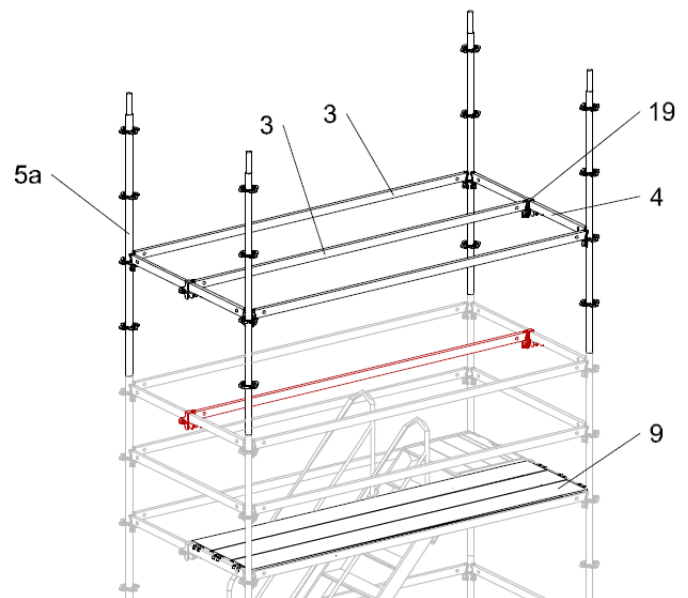

Fig.B6-4

Intermediate lift removed

Repeat steps as required according to tower height.

B6.4 Base level

Reposition Steel Decks UDG 300 (9) to position shown. (Fig.B6-5)

Remove the lower Ledger UH 300 (3), Ledger to Ledger Coupler UHA Half (18), Ledgers UH 150 (4), Ledgers UH 75 (17), Standard UVH 100 (5b) and Spigot UH (13)

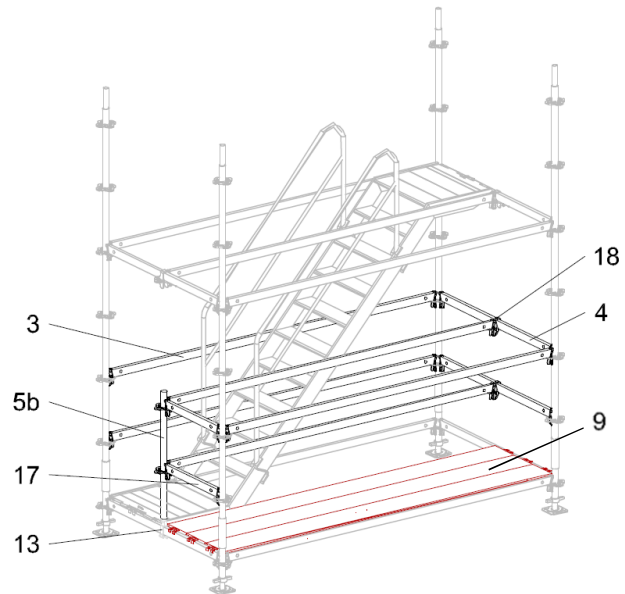

Fig.B6-5

Remove Staircase UAS (6) and Stair Guardrails UAG (8).

Remove Vertical Standards UVR 300 (5) and upper Ledgers UH 300 (3), Ledgers UH 150 (4) and Ledger to Ledger Coupler UHA Half (19).

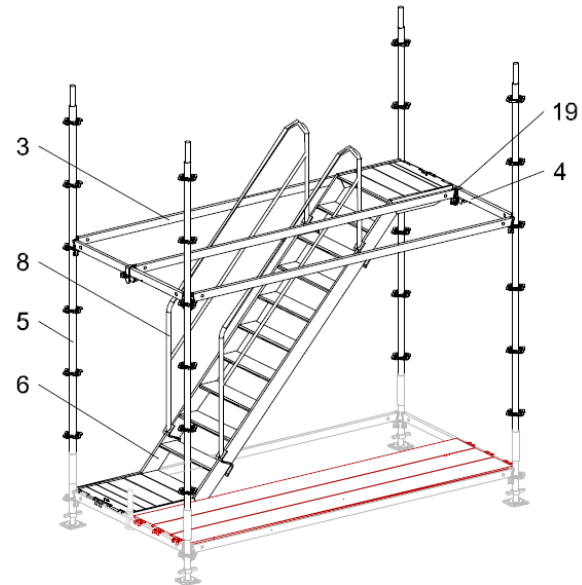

Fig.B6-6

From the ground, remove final base components

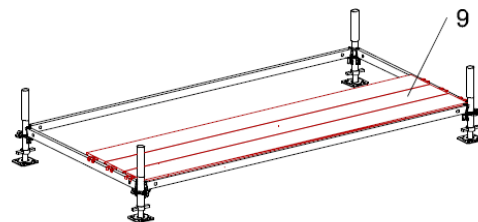

Fig.B6-7

Dismantling completed

B7.1 Reaction forces for legs

The reaction forces for the stair towers with in line staircase units are given in Table 2 and are dependant on the height of the tower, bay length and applied live load.

Maximum leg loads allow for the total live load with a 75/25 distribution on plan.

The live load assumption for the stair tower leg loads indicated is 2kN/m² for 20 linear metres. The equivalent number of persons indicated is based on an allowance of 100kg per person allowing for person self weight plus small tools in accordance with BS 5975.

PERI recommend that the user displays clear signage indicating the permissible limits for personnel numbers thus:

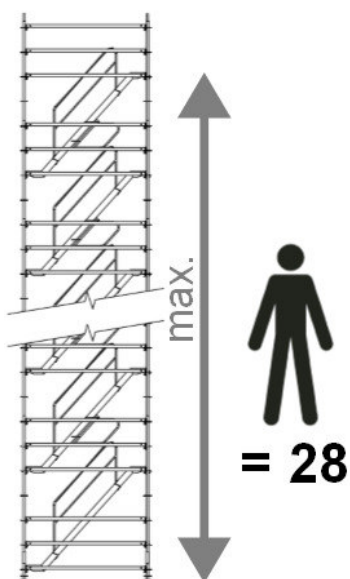
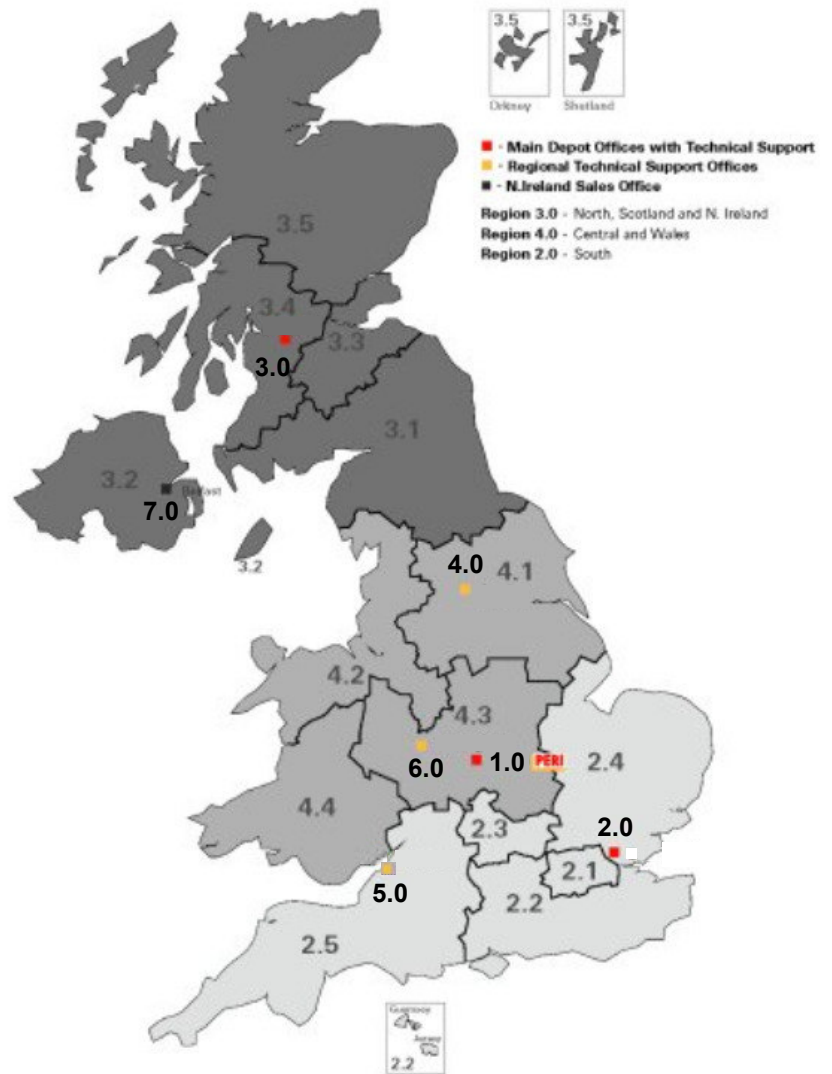

Fig.B7-1

Tower height (m)	Bay Length = 2.5m		Bay Length = 3.0m	
	Max. Leg Load	Equiv. No. of persons:	Max. Leg Load	Equiv. No. of persons:
2.3	3.6	7	4.2	8
4.3	6.8	14	8.0	17
6.3	8.6	18	11.8	26
8.3	10.5	21	13.4	28
10.3	12.4	25	14.0	28
12.3	14.2	28	14.6	28
14.3	14.7	28	15.2	28
16.3	15.3	28	15.8	28
18.3	15.8	28	16.4	28
20.3	16.3	28	17.0	28
22.3	16.8	28	17.6	28
24.3	17.4	28	18.2	28
26.3	17.9	28	18.8	28
28.3	18.4	28	19.4	28
30.3	19.0	28	20.0	28
32.3	19.5	28	20.6	28
34.3	20.0	28	21.2	28
36.3	20.5	28	21.8	28
38.3	21.1	28	22.4	28
40.3	21.6	28	23.0	28
42.3	22.1	28	23.6	28
44.3	22.7	28	24.2	28
46.3	23.2	28	24.8	28
48.3	23.7	28	25.4	28
50.3	24.2	28	26.0	28
52.3	24.8	28	26.7	28
54.3	25.4	28	27.3	28
56.3	25.9	28	27.9	28
58.3	26.5	28	28.5	28
60.3	27.0	28	29.1	28
62.3	27.6	28		
64.3	28.2	28		
66.3	28.7	28		

PERI Ltd

Contact information



1.0 Rugby

Head and Registered Office

Market Harborough Road
Clifton upon Dunsmore
Rugby
CV23 0AN

Tel: +44 (0)1788 861600

2.0 Brentwood

Warley Street
Great Warley
Brentwood
Essex
CM13 3JZ

Tel: +44 (0)1277 238820

5.0 Bristol

First Floor
Elm House
Fountain Court
Bradley Stoke
BS32 4LA

Tel: +44 (0)1291 626843

3.0 Glasgow

331 Charles Street
Glasgow
G21 2QA

Tel: +44 (0)141 553 5252

6.0 Birmingham

Unit 2625
Kings Court
The Crescent
Birmingham Business Park
Birmingham
B37 7YE

Tel: +44 (0)121 295 1345

4.0 Leeds

Office Suite C
Tuscany Way
Wakefield Europort
Normanton
West Yorkshire
WF6 2UA

Tel: +44 (0)1924 899 848

7.0 Belfast

3 Weavers Court Business Park
Linfield Road
Belfast
BT12 5GH

Tel: +44 (0)2890 224028

The optimum system
for every project and
every requirement



Wall formwork



Column formwork



Slab formwork



Climbing systems



Bridge formwork



Tunnel formwork



Shoring



Working scaffolds construction



Working scaffolds facade



Working scaffolds industry



Means of access



Safety scaffolds



Safety systems



System-independent accessories



Services



PERI Ltd
Market Harborough Road
Clifton upon Dunsmore
Rugby
CV23 0AN
Telephone +44 (0)71788 86 16 00
Fax +44 (0)71788 86 16 10
info@peri.ltd.uk
www.peri.ltd.uk

